

Excellent Integrated System Limited

Stocking Distributor

Click to view price, real time Inventory, Delivery & Lifecycle Information:

[FTDI, Future Technology Devices International Ltd](#)
[VSHLD-FT121](#)

For any questions, you can email us directly:

sales@integrated-circuit.com



**FT121 G Sensor Shield
Version 1.0**

Document Reference No.: FT_000916 Clearance No.: FTDI# 351

**Future Technology
Devices International
Ltd
Datasheet**

FT121 G Sensor Shield

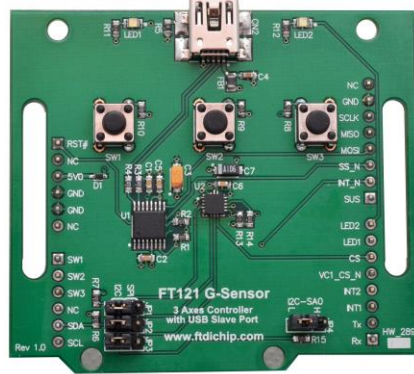

1 Introduction

The FT121 G-Sensor shield is designed to connect directly to an Arduino Pro development board. The shield allows the micro-controller on the Arduino Pro to access the FT121 USB device controller.

Using the FTDI FT121 chipset and a three axes linear accelerometer (ST LIS331DLH) device, the module may be used to implement a USB HID game controller.

The user may also define other interesting applications from the micro-controller board.

The Arduino Pro is a micro-controller board based on the ATmega168 or ATmega328 and is not available from FTDI.

1.1 Features

The FT121 G Sensor Shield has the following features:

- FT121 enhanced USB device controller with SPI interface.
- LIS313DLH 3- axis linear accelerometer (X, Y & Z) with selectable full scales of $\pm 2g/\pm 4g/\pm 8g$
- An SPI Interface: Data transfer over the SPI bus to the Arduino pro via pin headers
- Selectable SPI & I²C interface to control the 3- axes accelerometer
- A serial UART output pin
- Two accelerometer interrupts
- Three pushbuttons and two LEDs for HID application
- 5V USB cable power supplied operation
- Onboard 3.3V regulator to power the accelerometer
- Mini-B USB connector
- Operating Temperature range -40°C to +85°C



2 Typical Applications

The module may be used with the Arduino Pro for:

- USB HID controller
- USB Game controllers

3 Ordering Information

The module is sold as individual units as below:

Part No.	Description
VSHLD-FT121	FT121 G-Sensor Shield Board

Table 3-1 – Ordering information



Table of Contents

1	Introduction	1
1.1	Features.....	1
2	Typical Applications.....	2
3	Ordering Information	2
4	Pin Out and Signal Description	4
4.1	Shield Board Connector Description	4
4.2	Shield Board Connector : Pin and Signal Description.....	5
5	Hardware Functionality	7
5.1	Power.....	7
5.2	Input/Output	7
5.3	LEDS.....	7
5.4	Pushbutton	7
5.5	Switches	7
5.6	USB Controller Operation	8
5.7	Accelerometer Operation	9
6	Schematic.....	10
7	Mechanical Details.....	11
8	Contact Information	12
	Appendix A - References	23
	Appendix B - List of Figures and Tables.....	24
	Appendix C – Revision History.....	25

4 Pin Out and Signal Description

4.1 Shield Board Connector Description

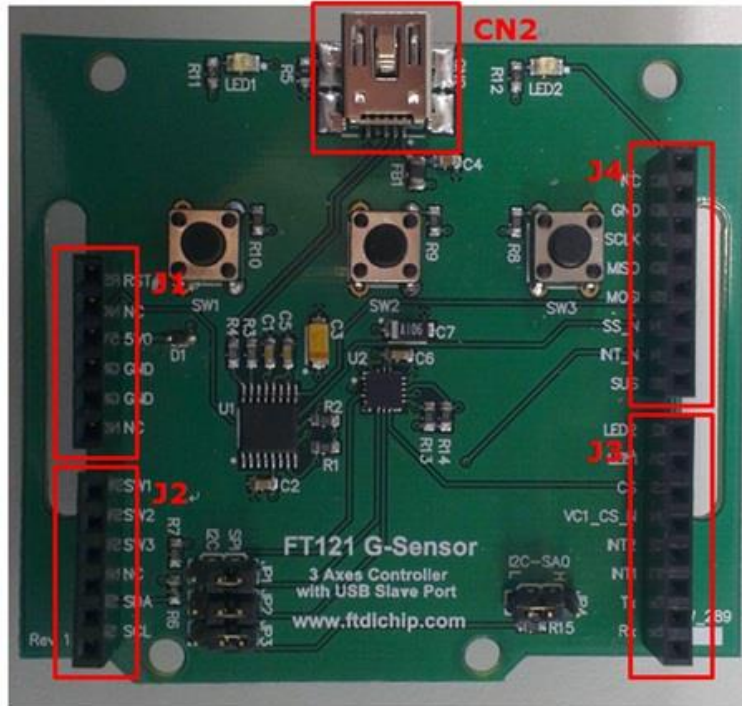

Figure 1 : Shield Board Top View

A detailed description of each pin out is given in the next section.

CONNECTOR	FUNCTION
CN2	USB Port Connector
J1	Interface to Arduino Pro
J2	Interface to Arduino Pro
J3	Interface to Arduino Pro
J4	Interface to Arduino Pro

Table 4-1 : Shield Board Connector Descriptions



4.2 Shield Board Connector : Pin and Signal Description

Pin No.	Name	Type	Description
J1-1	RESET	I	Reset for FT121
J1-2	NC	-	No Connection
J1-3	VCC5V	P	5V VBUS Power from USB connector
J1-4	GND	P	Ground
J1-5	GND	P	Ground
J1-6	NC	-	No Connection
<hr/>			
J2-1	SW1	O	Push button. Logic 0 output when pressed.
J2-2	SW2	O	Push button. Logic 0 output when pressed.
J2-3	SW3	O	Push button. Logic 0 output when pressed.
J2-4	NC	-	No Connection
J2-5	SDA	I/O	I2C Data
J2-6	SCL	I	I2C Clock
<hr/>			
J3-1	RX	I	UART Data Receiver via the Arduino
J3-2	TX	O	UART Data Transmitter via the Arduino
J3-3	INT1	O	LIS331DLH Interrupt 1
J3-4	INT2	O	LIS331DLH Interrupt 2
J3-5	VC1_CS_N	I	Reserve for VC1 Use
J3-6	CS	I	LIS331DLH SPI slave select input
J3-7	LED1	I	Blue LED. Active low to illuminate. Function defined by external controller
J3-8	LED2	I	Blue LED. Active low to illuminate. Function defined by external controller
<hr/>			
J4-1	SUSPEND	I, OD	FT121 Device suspend (output) and wakeup (input)
J4-2	INT_N	OD	Interrupt (Active Low)
J4-3	SS_N	I	FT121 SPI slave select input



**FT121 G Sensor Shield
Version 1.0**

Document Reference No.: FT_000916 Clearance No.: FTDI# 351

J4-4	MOSI	I	SPI Slave Input
J4-5	MISO	O	SPI Slave Output
Pin No.	Name	Type	Description
J4-6	SCLK	I	SPI Clock Input
J4-7	GND	P	Ground
J4-8	NC	-	

Table 4-2 : Pin Signal Descriptions



5 Hardware Functionality

5.1 Power

The 5V power from the USB cable is supplied to the G Sensor Shield and the Arduino Pro development board which controls the shield. This also supplies an onboard 3.3V regulator providing the power for the G-Sensor. The module will consume 20mA max.

5.2 Input/Output

The Arduino Pro development board is connected via pin headers. The USB controller and 3-axes accelerometer are accessed by the SPI interface between the boards. The 3-axes accelerometer can also be accessed by an I²C interface. The female header on the G-Sensor shield allows for stacking additional Arduino shields to perform additional applications. IO levels are 3.3V.

A Mini-B type USB connector to connect to the USB port from the host PC is also provided on the board.

5.3 LEADS

There are 2 LEDs on the shield board which may be controlled from the Arduino Pro GPIO signals. The function is defined by the application and may include indicating the X-axis directional movement or display debug. A logic 0 is required to illuminate the LED.

5.4 Pushbutton

There are 3 pushbuttons on the shield board which may be controlled from the Arduino Pro GPIO signals. The function is defined by the application and may be used in a game setting as the three buttons required for a game controller. The output is logic 1 until the button is pushed.

5.5 Switches

There are two methods to control the accelerometer. Using an SPI interface, or using an I²C interface. JP1, JP2, JP3 are used to select the accelerometer control bus mode on the shield board.

Pin Number	Description
Pin1-Pin2	SPI Mode
Pin2-Pin3	I2C Mode

Table 5-1 : LIS331DLH Control Bus Mode

In I²C mode JP4 is used to set the device address. JP4 is not used in SPI mode.

Pin Number	Description
Pin1-Pin2	SA0 High
Pin2-Pin3	SA0 Low

Table 5-2 : LIS331DLH I2C Device Address

5.6 USB Controller Operation

The USB controller, the FTDI FT121 IC converts the USB bus data to SPI data. The SPI port is a slave to the Arduino Pro SPI Master. SPI Master and GPIO drivers are supplied with the Arduino Toolchain to allow programming and reading data over the SPI interface to the FT121 IC. Users can define standard USB protocol drivers such as HID, CDC class, etc, from the microcontroller.

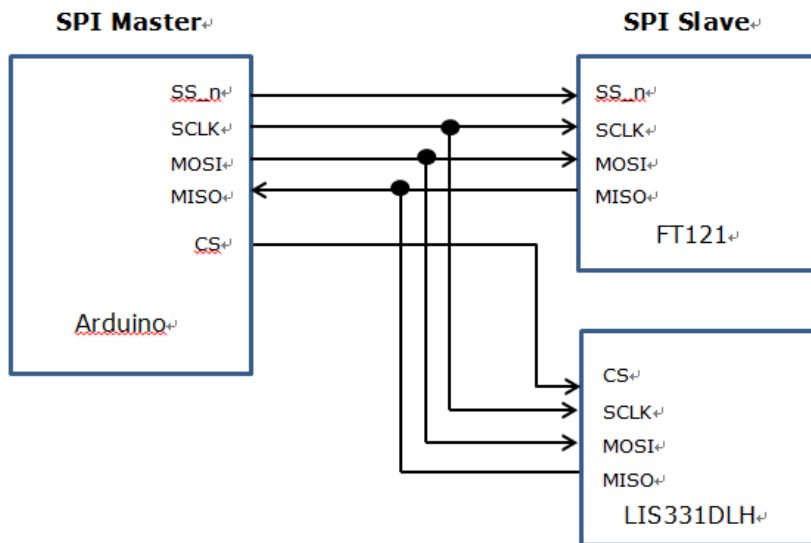

Figure 2 : SPI Bus Communication

5.7 Accelerometer Operation

The accelerometer is an ST LIS331DLH, allowing the 3-axes movement information to be accessed through either the SPI bus or the I²C bus. The interface is selectable by changing the jumpers JP1 to JP4 and setting the LIS331DLH chip select pin to high.

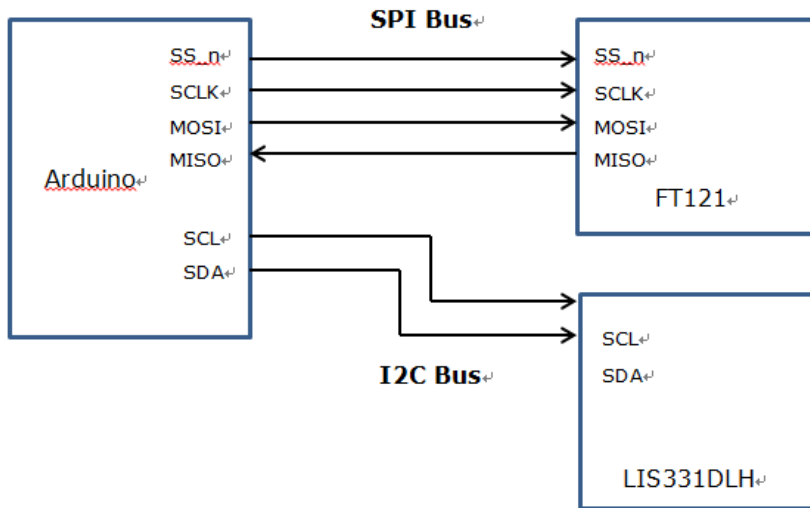

Figure 3 : LIS331DLH I²C Communication

6 Schematic

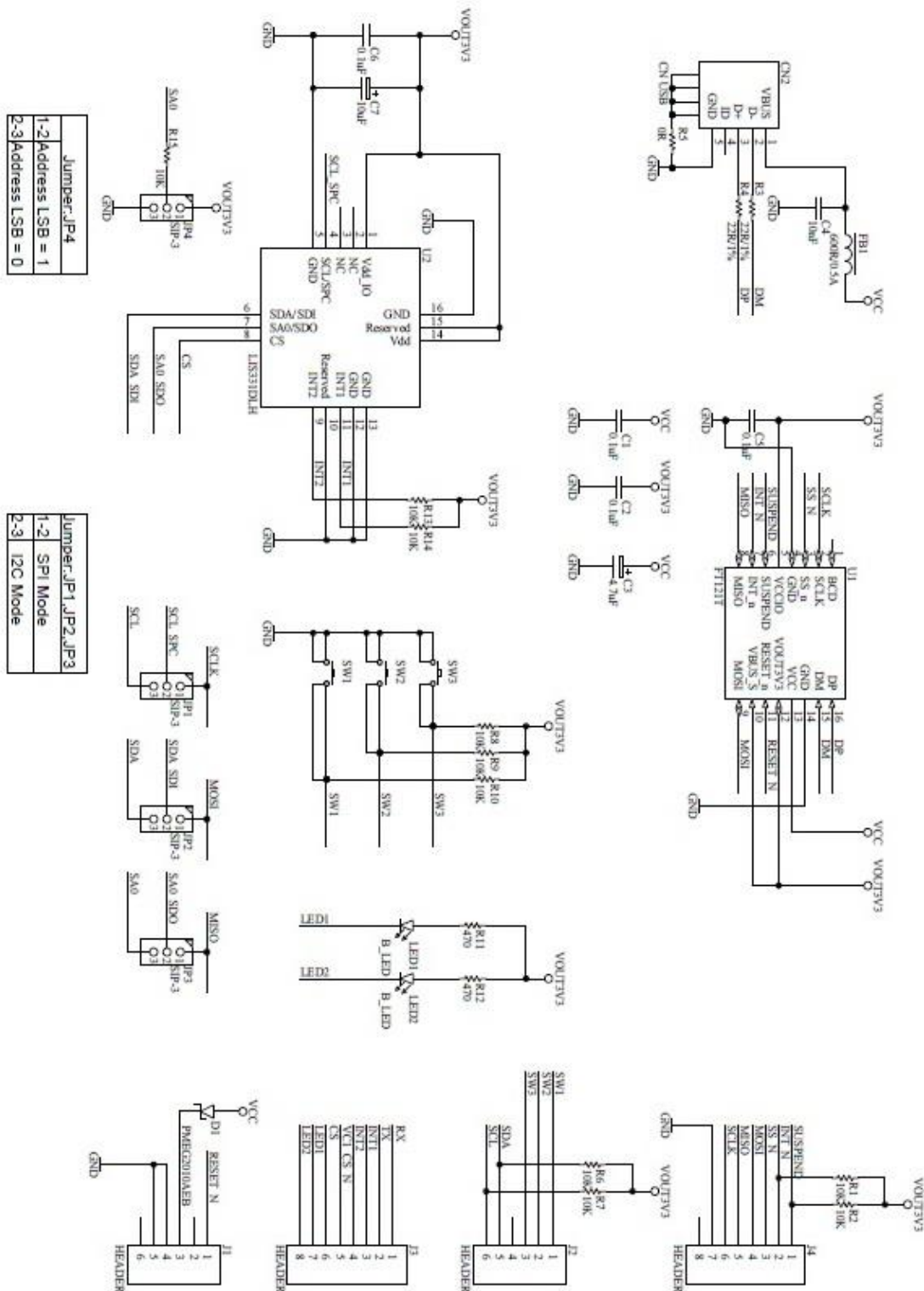

Figure 4 : Schematic

7 Mechanical Details

The module dimensions in mm are:

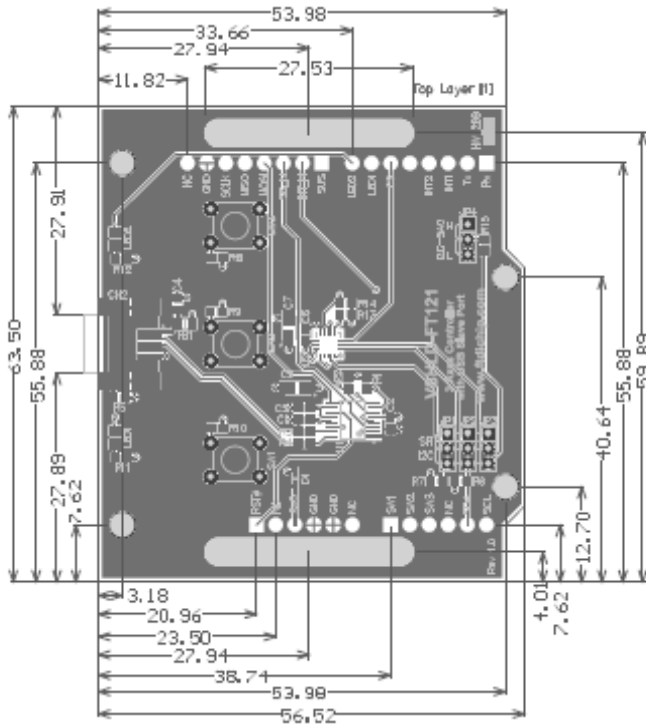

Figure 5 : Mechanical Dimensions



8 Contact Information

Head Office – Glasgow, UK

Unit 1, 2 Seaward Place, Centurion Business Park
Glasgow G41 1HH
United Kingdom
Tel: +44 (0) 141 429 2777
Fax: +44 (0) 141 429 2758

E-mail (Sales) sales1@ftdichip.com
E-mail (Support) support1@ftdichip.com
E-mail (General Enquiries) admin1@ftdichip.com

Branch Office – Tigard, Oregon, USA

7130 SW Fir Loop
Tigard, OR 97223
USA
Tel: +1 (503) 547 0988
Fax: +1 (503) 547 0987

E-Mail (Sales) us.sales@ftdichip.com
E-Mail (Support) us.support@ftdichip.com
E-Mail (General Enquiries) us.admin@ftdichip.com

Branch Office – Taipei, Taiwan

2F, No. 516, Sec. 1, NeiHu Road
Taipei 114
Taiwan, R.O.C.
Tel: +886 (0) 2 8797 1330
Fax: +886 (0) 2 8751 9737

E-mail (Sales) tw.sales1@ftdichip.com
E-mail (Support) tw.support1@ftdichip.com
E-mail (General Enquiries) tw.admin1@ftdichip.com

Branch Office – Shanghai, China

Room 1103, No. 666 West Huaihai Road,
Changning District, Shanghai, 200052
China
Tel: +86 (0)21 6235 1596
Fax: +86 (0)21 6235 1595

E-mail (Sales) cn.sales@ftdichip.com
E-mail (Support) cn.support@ftdichip.com
E-mail (General Enquiries) cn.admin@ftdichip.com

Web Site

<http://ftdichip.com>

Distributor and Sales Representatives

Please visit the Sales Network page of the [FTDI Web site](#) for the contact details of our distributor(s) and sales representative(s) in your country.

System and equipment manufacturers and designers are responsible to ensure that their systems, and any Future Technology Devices International Ltd (FTDI) devices incorporated in their systems, meet all applicable safety, regulatory and system-level performance requirements. All application-related information in this document (including application descriptions, suggested FTDI devices and other materials) is provided for reference only. While FTDI has taken care to assure it is accurate, this information is subject to customer confirmation, and FTDI disclaims all liability for system designs and for any applications assistance provided by FTDI. Use of FTDI devices in life support and/or safety applications is entirely at the user's risk, and the user agrees to defend, indemnify and hold harmless FTDI from any and all damages, claims, suits or expense resulting from such use. This document is subject to change without notice. No freedom to use patents or other intellectual property rights is implied by the publication of this document. Neither the whole nor any part of the information contained in, or the product described in this document, may be adapted or reproduced in any material or electronic form without the prior written consent of the copyright holder. Future Technology Devices International Ltd, Unit 1, 2 Seaward Place, Centurion Business Park, Glasgow G41 1HH, United Kingdom. Scotland Registered Company Number: SC136640



Appendix A - References

For module documentations, please refer to URL below:

FT121 datasheet

http://www.ftdichip.com/Support/Documents/DataSheets/ICs/DS_FT121.pdf

LIS331DLH G sensor datasheet datasheet

<http://www.st.com/st-web-ui/static/active/en/resource/technical/document/datasheet/CD00213470.pdf>

Arduino Pro home page

<http://arduino.cc/en/Main/ArduinoBoardPro>



Appendix B - List of Figures and Tables

List of Figures

Figure 1 : Shield Board Top View	4
Figure 2 : SPI Bus Communication.....	8
Figure 3 : LIS331DLH I ² C Communication	9
Figure 4 : Schematic.....	10
Figure 5 : Mechanical Dimensions.....	11

List of Tables

Table 3-1 – Ordering information	2
Table 4-1 : Shield Board Connector Descriptions.....	4
Table 4-2 : Pin Signal Descriptions.....	6
Table 5-1 : LIS331DLH Control Bus Mode.....	7
Table 5-2 : LIS331DLH I2C Device Address	8



Appendix C – Revision History

Document Title: FT121 G Sensor Shield
Document Reference No.: FT_000916
Clearance No.: FTDI# 351
Product Page: <http://www.ftdichip.com/Products/Modules/DevelopmentModules.htm>
Document Feedback: [Send Feedback](#)

Version 1.0 Initial Datasheet released

Oct 2013