

Excellent Integrated System Limited

Stocking Distributor

Click to view price, real time Inventory, Delivery & Lifecycle Information:

[Maxim Integrated](#)
[MAX987EUK-T](#)

For any questions, you can email us directly:
sales@integrated-circuit.com



High-Speed, Micropower, Low-Voltage, SOT23, Rail-to-Rail I/O Comparators

General Description

The MAX987/MAX988/MAX991/MAX992/MAX995/MAX996 single/dual/quad micropower comparators feature low-voltage operation and rail-to-rail inputs and outputs. Their operating voltage ranges from +2.5V to +5.5V, making them ideal for both 3V and 5V systems. These comparators also operate with $\pm 1.25V$ to $\pm 2.75V$ dual supplies. They consume only 48 μA per comparator while achieving a 120ns propagation delay.

Input bias current is typically 1.0pA, and input offset voltage is typically 0.5mV. Internal hysteresis ensures clean output switching, even with slow-moving input signals.

The output stage's unique design limits supply-current surges while switching, virtually eliminating the supply glitches typical of many other comparators. The MAX987/MAX991/MAX995 have a push-pull output stage that sinks as well as sources current. Large internal output drivers allow rail-to-rail output swing with loads up to 8mA. The MAX988/MAX992/MAX996 have an open-drain output stage that can be pulled beyond VCC to 6V (max) above VEE. These open-drain versions are ideal for level translators and bipolar to single-ended converters.

The single MAX987/MAX988 are available in tiny 5-pin SC70 packages, while the dual MAX991/MAX992 are available in ultra-small 8-pin SOT23 and μMAX ® packages.

Selector Guide

PART	COMPARATORS PER PACKAGE	OUTPUT STAGE
MAX987	1	Push-Pull
MAX988	1	Open-Drain
MAX991	2	Push-Pull
MAX992	2	Open-Drain
MAX995	4	Push-Pull
MAX996	4	Open-Drain

Applications

Portable/Battery-Powered Systems	Threshold Detectors/Discriminators
Mobile Communications	Ground/Supply Sensing
Zero-Crossing Detectors	IR Receivers
Window Comparators	Digital Line Receivers
Level Translators	

μMAX is a registered trademark of Maxim Integrated Products, Inc.

Features

- ◆ 120ns Propagation Delay
- ◆ 48 μA Quiescent Supply Current
- ◆ +2.5V to +5.5V Single-Supply Operation
- ◆ Common-Mode Input Voltage Range Extends 250mV Beyond the Rails
- ◆ Push-Pull Output Stage Sinks and Sources 8mA Current (MAX987/MAX991/MAX995)
- ◆ Open-Drain Output Voltage Extends Beyond VCC (MAX988/MAX992/MAX996)
- ◆ Unique Output Stage Reduces Output Switching Current, Minimizing Overall Power Consumption
- ◆ 100 μA Supply Current at 1MHz Switching Frequency
- ◆ No Phase Reversal for Overdriven Inputs
- ◆ Available in Space-Saving Packages:
 - 5-Pin SOT23 (MAX987/MAX988)
 - 8-Pin μMAX (MAX991/MAX992)

Ordering Information

PART	PIN-PACKAGE	PKG CODE	TOP MARK
MAX987EXK-T	5 SC70-5	X5-1	ABM
MAX987EUK-T	5 SOT23-5	U5-1	ABZB
MAX987ESA	8 SO	S8-2	—

Ordering Information continued at end of data sheet.

Note: All devices specified over the -40°C to +85°C operating temperature range.

Typical Application Circuit appears at end of data sheet.

Pin Configurations

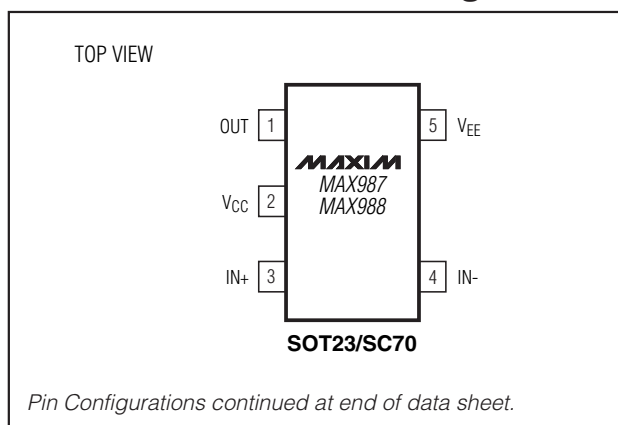

MAX987/MAX988/MAX991/MAX992/MAX995/MAX996

High-Speed, Micropower, Low-Voltage, SOT23, Rail-to-Rail I/O Comparators

ABSOLUTE MAXIMUM RATINGS

Supply Voltage (VCC to VEE)	6V	5-Pin SOT23 (derate 7.10mW/°C above +70°C).....	571mW
IN ₋ , IN ₊ to VEE	-0.3V to (VCC + 0.3V)	8-Pin SOT23 (derate 9.1mW/°C above +70°C).....	727mW
Current into Input Pins	±20mA	8-Pin SO (derate 5.88mW/°C above +70°C).....	471mW
OUT ₋ to VEE		8-Pin μMAX (derate 4.5mW/°C above +70°C).....	362mW
MAX987/MAX991/MAX995	-0.3V to (VCC + 0.3V)	14-Pin TSSOP (derate 9.1mW/°C above +70°C).....	727mW
MAX988/MAX992/MAX996	-0.3V to +6V	14-Pin SO (derate 8.33mW/°C above +70°C).....	667mW
OUT ₋ Short-Circuit Duration to VEE or VCC	10s	Operating Temperature Range	-40°C to +85°C
Continuous Power Dissipation (T _A = +70°C)		Storage Temperature Range	-65°C to +150°C
5-Pin SC70 (derate 3.1mW/°C above +70°C).....	247mW	Lead Temperature (soldering, 10s).....	+300°C

Stresses beyond those listed under "Absolute Maximum Ratings" may cause permanent damage to the device. These are stress ratings only, and functional operation of the device at these or any other conditions beyond those indicated in the operational sections of the specifications is not implied. Exposure to absolute maximum rating conditions for extended periods may affect device reliability.

ELECTRICAL CHARACTERISTICS (Note 1)

(VCC = +2.7V to +5.5V, VEE = 0V, VCM = 0V, TA = -40°C to +85°C, unless otherwise noted. Typical values are at TA = +25°C.)

PARAMETER	SYMBOL	CONDITIONS		MIN	TYP	MAX	UNITS
Supply Voltage	VCC	Inferred from PSRR test		2.5		5.5	V
Supply Current per Comparator	ICC	VCC = 5V	TA = +25°C		53	80	μA
			TA = -40°C to +85°C			96	
		VCC = 2.7V	TA = +25°C		48	80	
			TA = -40°C to +85°C			96	
Power-Supply Rejection Ratio	PSRR	2.5V ≤ VCC ≤ 5.5V		55	80		dB
Common-Mode Voltage Range (Note 2)	VCMR	TA = +25°C		VEE - 0.25		VCC + 0.25	V
		TA = -40°C to +85°C		VEE		VCC	
Input Offset Voltage (Note 3)	VOS	Full common-mode range	TA = +25°C		±0.5	±5	mV
			TA = -40°C to +85°C			±7	
Input Hysteresis	VHYST				±2.5		mV
Input Bias Current (Note 4)	IB				0.001	10	nA
Input Offset Current	IOS				0.5		pA
Input Capacitance	CIN				1.0		pF
Common-Mode Rejection Ratio	CMRR			50	80		dB
Output Leakage Current (MAX988/MAX992/MAX996 only)	I _{LEAK}	V _{OUT} = high				1.0	μA
Output Short-Circuit Current	ISC	Sourcing or sinking, V _{OUT} = VEE or VCC		VCC = 5V		95	mA
				VCC = 2.7V		35	
OUT Output-Voltage Low	VOL	VCC = 5V, ISINK = 8mA	TA = +25°C		0.2	0.4	V
			TA = -40°C to +85°C				
		VCC = 2.7V, ISINK = 3.5mA	TA = +25°C		0.15	0.3	
			TA = -40°C to +85°C				
OUT Output-Voltage High (MAX987/MAX991/MAX995 Only)	VOH	VCC = 5V, ISOURCE = 8mA	TA = +25°C		4.6	4.85	V
			TA = -40°C to +85°C			4.45	
		VCC = 2.7V, ISOURCE = 3.5mA	TA = +25°C		2.4	2.55	
			TA = -40°C to +85°C			2.3	

High-Speed, Micropower, Low-Voltage, SOT23, Rail-to-Rail I/O Comparators

ELECTRICAL CHARACTERISTICS (continued)

(V_{CC} = +2.7V to +5.5V, V_{EE} = 0V, V_{CM} = 0V, T_A = -40°C to +85°C, unless otherwise noted. Typical values are at T_A = +25°C.)

PARAMETER	SYMBOL	CONDITIONS		MIN	TYP	MAX	UNITS
OUT Rise Time (MAX987/MAX991/ MAX995 Only)	t _{RISE}	V _{CC} = 5.0V	C _L = 15pF		15		ns
			C _L = 50pF		20		
			C _L = 200pF		40		
OUT Fall Time	t _{FALL}	V _{CC} = 5.0V	C _L = 15pF		15		ns
			C _L = 50pF		20		
			C _L = 200pF		40		
Propagation Delay	t _{PD-}	C _L = 15pF, V _{CC} = 5V	MAX987/MAX991/ MAX995 only	10mV overdrive		210	ns
				100mV overdrive		120	
			MAX988/MAX992/ MAX996 only, R _{PULLUP} = 5.1kΩ	10mV overdrive		210	
				100mV overdrive		120	
	t _{PD+}	MAX987/MAX991/MAX995 only, C _L = 15pF, V _{CC} = 5V	10mV overdrive		210		
		100mV overdrive		120			
Power-Up Time	t _{PU}				25		μs

Note 1: All device specifications are 100% production tested at T_A = +25°C. Limits over the extended temperature range are guaranteed by design, not production tested.

Note 2: Inferred from the V_{OS} test. Either or both inputs can be driven 0.3V beyond either supply rail without output phase reversal.

Note 3: V_{OS} is defined as the center of the hysteresis band at the input.

Note 4: I_B is defined as the average of the two input bias currents (I_{B-}, I_{B+}).

MAX987/MAX988/MAX991/MAX992/MAX995/MAX996

High-Speed, Micropower, Low-Voltage, SOT23, Rail-to-Rail I/O Comparators

Typical Operating Characteristics

($V_{CC} = +5V$, $V_{CM} = 0V$, $T_A = +25^\circ C$, unless otherwise noted.)

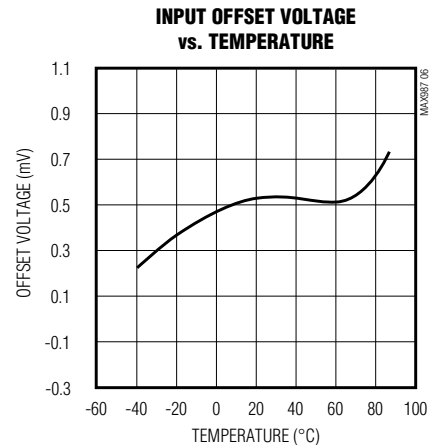
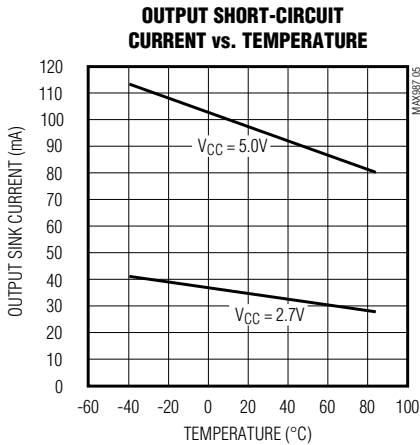
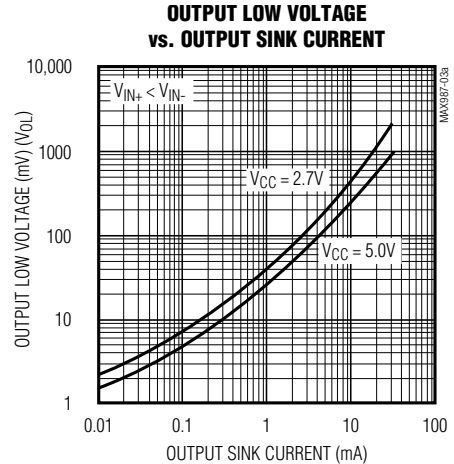
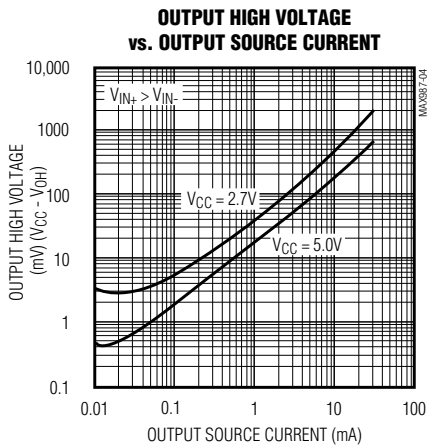
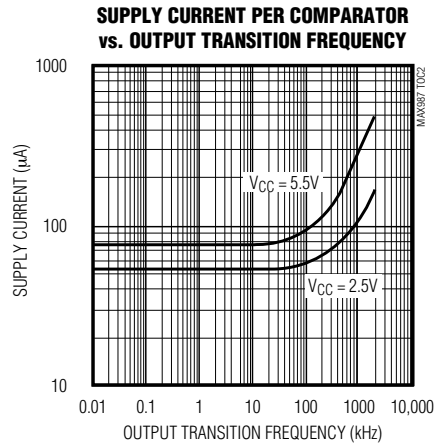
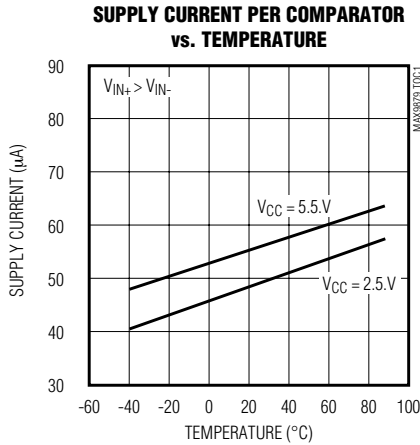

High-Speed, Micropower, Low-Voltage, SOT23, Rail-to-Rail I/O Comparators

Typical Operating Characteristics (continued)

(V_{CC} = +5V, V_{CM} = 0V, T_A = +25°C, unless otherwise noted.)

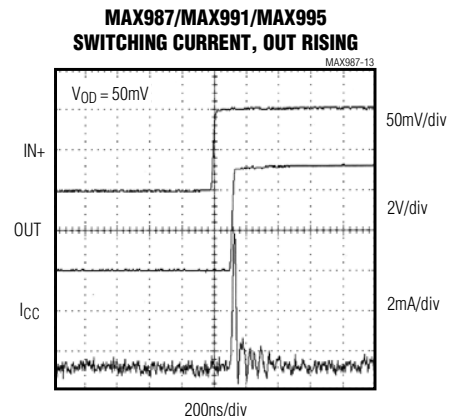
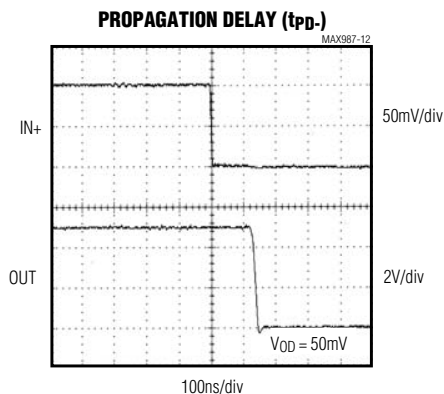
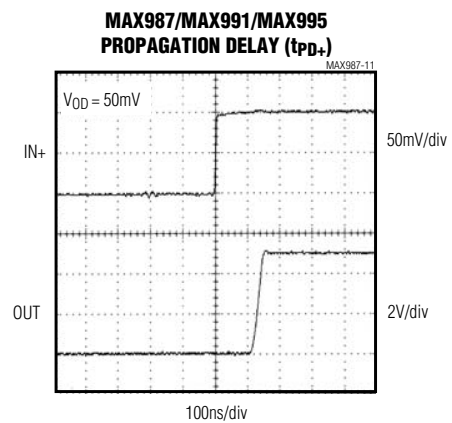
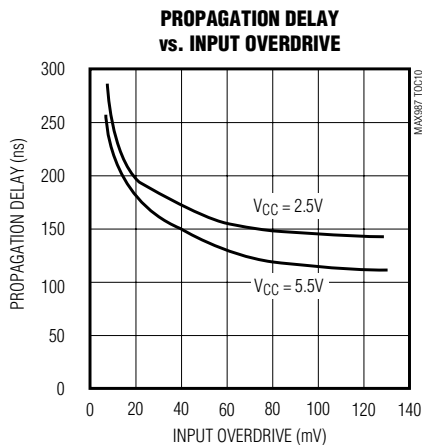
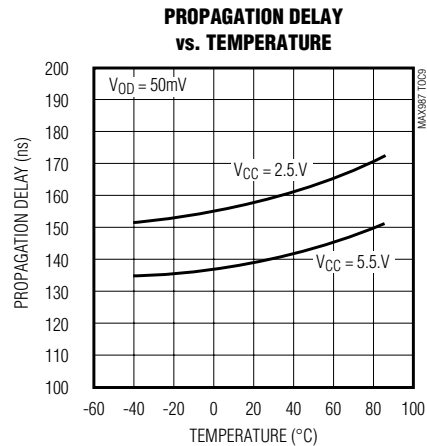
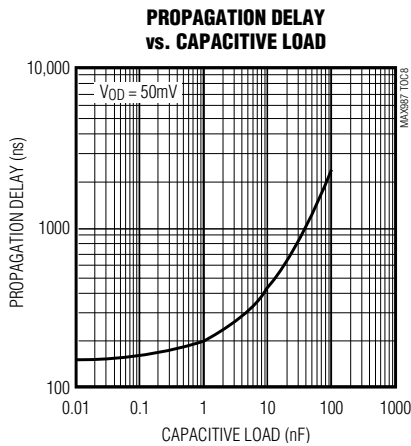

MAX987/MAX988/MAX991/MAX992/MAX995/MAX996

High-Speed, Micropower, Low-Voltage, SOT23, Rail-to-Rail I/O Comparators

Typical Operating Characteristics (continued)

(VCC = +5V, VCM = 0V, TA = +25°C, unless otherwise noted.)

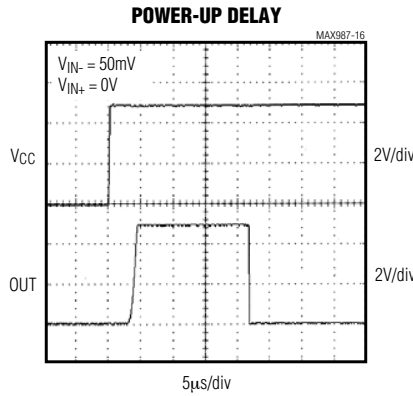
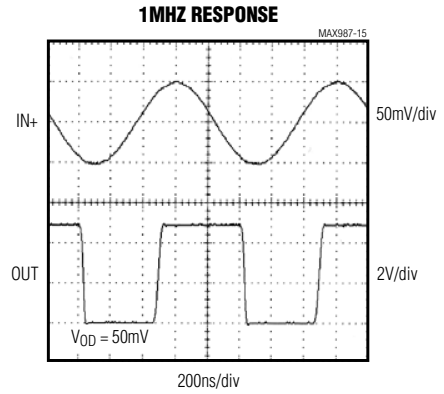
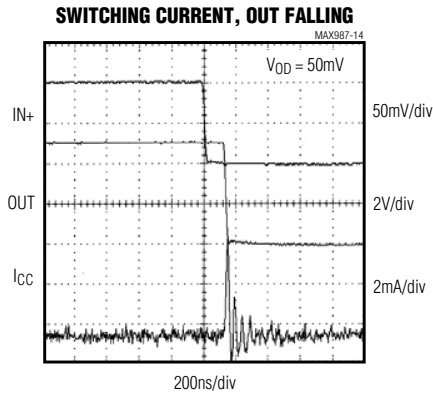

MAX987/MAX988/MAX991/MAX992/MAX995/MAX996

High-Speed, Micropower, Low-Voltage, SOT23, Rail-to-Rail I/O Comparators

Pin Description

PIN				NAME	FUNCTION
MAX987 MAX988		MAX991 MAX996	MAX995 MAX996		
SOT23/ SC70	SO	SO/ μ MAX/ SOT23	SO/ TSSOP		
1	6	—	—	OUT	Comparator Output
2	7	8	4	VCC	Positive Supply Voltage
3	3	—	—	IN+	Comparator Noninverting Input
4	2	—	—	IN-	Comparator Inverting Input
5	4	4	11	VEE	Negative Supply Voltage
—	—	1	1	OUTA	Comparator A Output
—	—	2	2	INA-	Comparator A Inverting Input
—	—	3	3	INA+	Comparator A Noninverting Input
—	—	5	5	INB+	Comparator B Noninverting Input
—	—	6	6	INB-	Comparator B Inverting Input
—	—	7	7	OUTB	Comparator B Output
—	—	—	8	OUTC	Comparator C Output
—	—	—	9	INC-	Comparator C Inverting Input
—	—	—	10	INC+	Comparator C Noninverting Input
—	—	—	12	IND+	Comparator D Noninverting Input
—	—	—	13	IND-	Comparator D Inverting Input
—	—	—	14	OUTD	Comparator D Output
—	1, 5, 8	—	—	N.C.	No Connection. Not internally connected.

MAX987/MAX988/MAX991/MAX992/MAX995/MAX996

High-Speed, Micropower, Low-Voltage, SOT23, Rail-to-Rail I/O Comparators

MAX987/MAX988/MAX991/MAX992/MAX995/MAX996

Detailed Description

The MAX987/MAX988/MAX991/MAX992/MAX995/MAX996 are single/dual/quad low-power, low-voltage comparators. They have an operating supply voltage range between +2.5V and +5.5V and consume only 48µA per comparator, while achieving 120ns propagation delay. Their common-mode input voltage range extends 0.25V beyond each rail. Internal hysteresis ensures clean output switching, even with slow-moving input signals. Large internal output drivers allow rail-to-rail output swing with up to 8mA loads.

The output stage employs a unique design that minimizes supply-current surges while switching, virtually eliminating the supply glitches typical of many other comparators. The MAX987/MAX991/MAX995 have a push-pull output structure that sinks as well as sources current. The MAX988/MAX992/MAX996 have an open-drain output stage that can be pulled beyond VCC to an absolute maximum of 6V above VEE.

Input Stage Circuitry

The devices' input common-mode range extends from -0.25V to (VCC + 0.25V). These comparators may operate at any differential input voltage within these limits. Input bias current is typically 1.0pA if the input voltage is between the supply rails. Comparator inputs are protected from overvoltage by internal body diodes connected to the supply rails. As the input voltage exceeds the supply rails, these body diodes become forward biased and begin to conduct. Consequently, bias currents increase exponentially as the input voltage exceeds the supply rails.

Output Stage Circuitry

These comparators contain a unique output stage capable of rail-to-rail operation with up to 8mA loads. Many comparators consume orders of magnitude more current during switching than during steady-state operation. However, with this family of comparators, the supply-current change during an output transition is extremely small. The *Typical Operating Characteristics* Supply Current vs. Output Transition Frequency graph shows the minimal supply-current increase as the output switching frequency approaches 1MHz. This characteristic eliminates the need for power-supply filter capacitors to reduce glitches created by comparator switching currents. Battery life increases substantially in high-speed, battery-powered applications.

Applications Information

Additional Hysteresis

MAX987/MAX991/MAX995

The MAX987/MAX991/MAX995 have ±2.5mV internal hysteresis. Additional hysteresis can be generated with three resistors using positive feedback (Figure 1). Unfortunately, this method also slows hysteresis response time. Use the following procedure to calculate resistor values for the MAX987/MAX991/MAX995.

- 1) Select R3. Leakage current at IN is under 10nA; therefore, the current through R3 should be at least 1µA to minimize errors caused by leakage current. The current through R3 at the trip point is (VREF - VOUT) / R3. Considering the two possible output states and solving for R3 yields two formulas: $R3 = VREF / 1\mu A$ or $R3 = (VREF - VCC) / 1\mu A$. Use the smaller of the two resulting resistor values. For example, if VREF = 1.2V and VCC = 5V, then the two R3 resistor values are 1.2MΩ and 3.8MΩ. Choose a 1.2MΩ standard value for R3.
- 2) Choose the hysteresis band required (VHB). For this example, choose 50mV.
- 3) Calculate R1 according to the following equation:

$$R1 = R3 \times (VHB / VCC)$$

For this example, insert the values $R1 = 1.2M\Omega \times (50mV / 5V) = 12k\Omega$.

- 4) Choose the trip point for VIN rising (VTHR; VTHF is the trip point for VIN falling). This is the threshold voltage at which the comparator switches its output from low to high as VIN rises above the trip point. For this example, choose 3V.

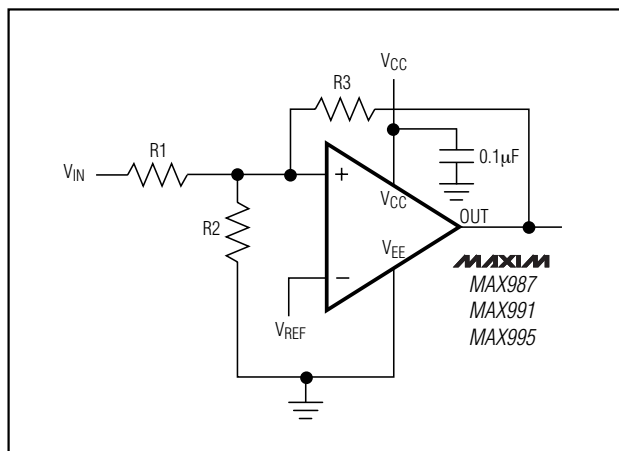

Figure 1. Additional Hysteresis (MAX987/MAX991/MAX995)

High-Speed, Micropower, Low-Voltage, SOT23, Rail-to-Rail I/O Comparators

5) Calculate R2 as shown. For this example, choose an 8.2kΩ standard value:

$$R2 = \frac{1}{\left(\frac{V_{THR}}{V_{REF} \times R1}\right) - \frac{1}{R1} - \frac{1}{R3}}$$

$$R2 = \frac{1}{\left(\frac{3.0V}{1.2 \times 12k\Omega}\right) - \frac{1}{12k\Omega} - \frac{1}{2.2M\Omega}} = 8.03k\Omega$$

6) Verify trip voltages and hysteresis as follows:

$$V_{IN \text{ rising}}: V_{THR} = V_{REF} \times R1 \times \left(\frac{1}{R1} + \frac{1}{R2} + \frac{1}{R3}\right)$$

$$V_{IN \text{ falling}}: V_{THF} = V_{THR} - \left(\frac{R1 \times V_{CC}}{R3}\right)$$

$$\text{Hysteresis} = V_{THR} - V_{THF}$$

MAX988/MAX992/MAX996

The MAX988/MAX992/MAX996 have ±2.5mV internal hysteresis. They have open-drain outputs and require an external pullup resistor (Figure 2). Additional hysteresis can be generated using positive feedback, but the formulas differ slightly from those of the MAX987/MAX991/MAX995.

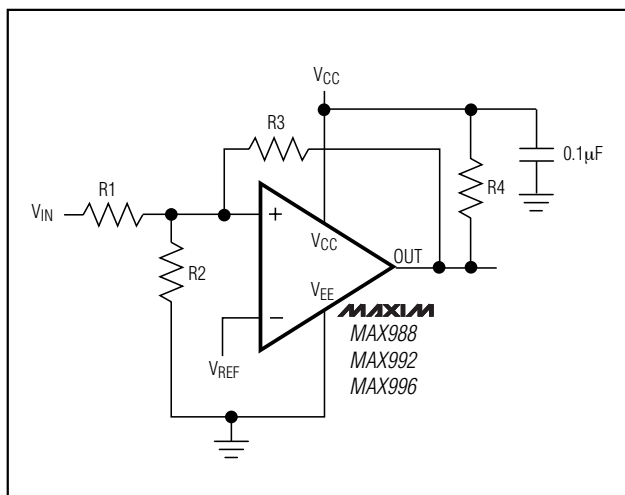

Figure 2. Additional Hysteresis (MAX988/MAX992/MAX996)

Use the following procedure to calculate resistor values:

- 1) Select R3 according to the formulas $R3 = V_{REF} / 1\mu A$ or $R3 = (V_{REF} - V_{CC}) / 1\mu A - R4$. Use the smaller of the two resulting resistor values.
- 2) Choose the hysteresis band required (V_{HB}). For this example, choose 50mV.
- 3) Calculate R1 according to the following equation:

$$R1 = (R3 + R4) \times (V_{HB} / V_{CC})$$
- 4) Choose the trip point for V_{IN} rising (V_{THR} ; V_{THF} is the trip point for V_{IN} falling). This is the threshold voltage at which the comparator switches its output from low to high as V_{IN} rises above the trip point.
- 5) Calculate R2 as follows:

$$R2 = \frac{1}{\left(\frac{V_{THR}}{V_{REF} \times R1}\right) - \frac{1}{R1} - \frac{1}{R3 + R4}}$$

6) Verify trip voltages and hysteresis as follows:

$$V_{IN \text{ rising}}: V_{THR} = V_{REF} \times R1 \times \left(\frac{1}{R1} + \frac{1}{R2} + \frac{1}{R3 + R4}\right)$$

$$V_{IN \text{ falling}}: V_{THF} = V_{THR} - \left(\frac{R1 \times V_{CC}}{R3 + R4}\right)$$

$$\text{Hysteresis} = V_{THR} - V_{THF}$$

Circuit Layout and Bypassing

These comparators' high-gain bandwidth requires design precautions to maximize their high-speed capability. The recommended precautions are:

- 1) Use a PCB with an unbroken, low-inductance ground plane.
- 2) Place a decoupling capacitor (a 0.1µF ceramic capacitor is a good choice) as close to VCC as possible.
- 3) On the inputs and outputs, keep lead lengths short to avoid unwanted parasitic feedback around the comparators.
- 4) Solder the devices directly to the PCB instead of using a socket.

High-Speed, Micropower, Low-Voltage, SOT23, Rail-to-Rail I/O Comparators

Zero-Crossing Detector

Figure 3 shows a zero-crossing detector application. The MAX987's inverting input is connected to ground, and its noninverting input is connected to a 100mVp-p signal source. As the signal at the noninverting input crosses 0V, the comparator's output changes state.

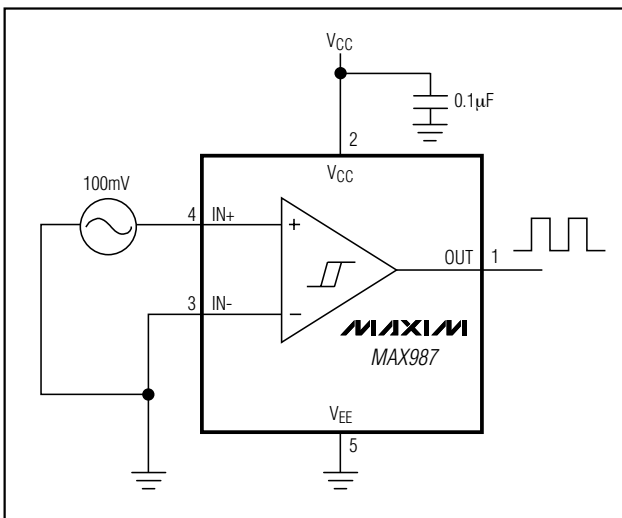

Figure 3. Zero-Crossing Detector

Logic-Level Translator

Figure 4 shows an application that converts 5V logic levels to 3V logic levels. The MAX988 is powered by the +5V supply voltage, and the pullup resistor for the MAX988's open-drain output is connected to the +3V supply voltage. This configuration allows the full 5V logic swing without creating overvoltage on the 3V logic inputs. For 3V to 5V logic-level translation, simply connect the +3V supply to VCC and the +5V supply to the pullup resistor.

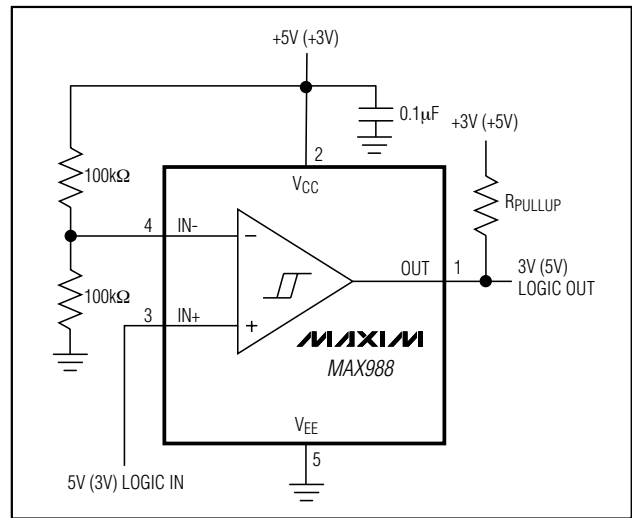
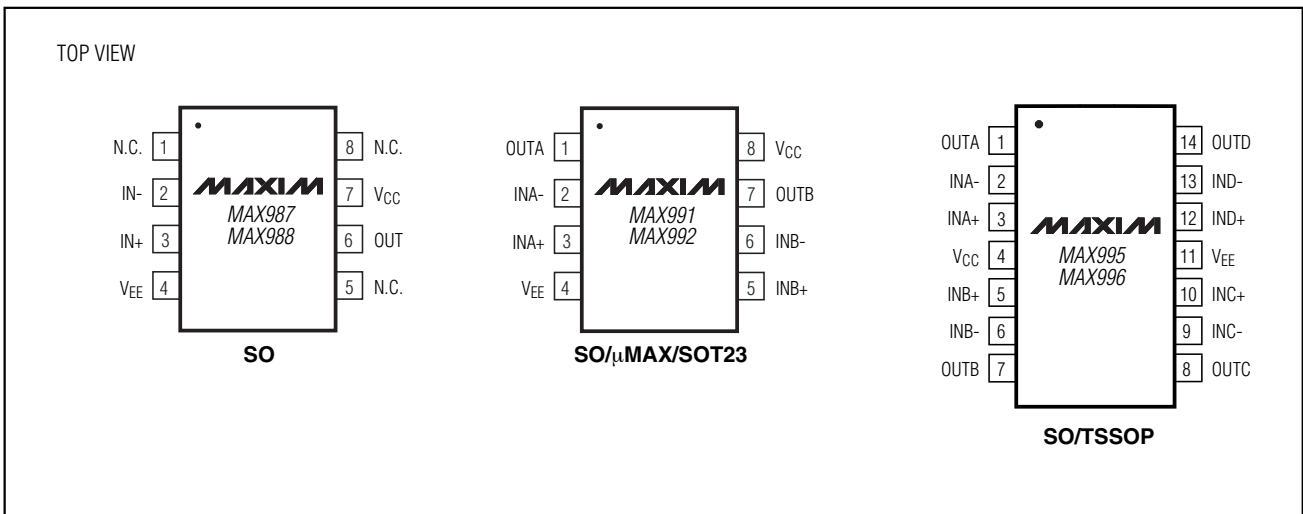

Figure 4. Logic-Level Translator

Pin Configurations (continued)



High-Speed, Micropower, Low-Voltage, SOT23, Rail-to-Rail I/O Comparators

Typical Application Circuit

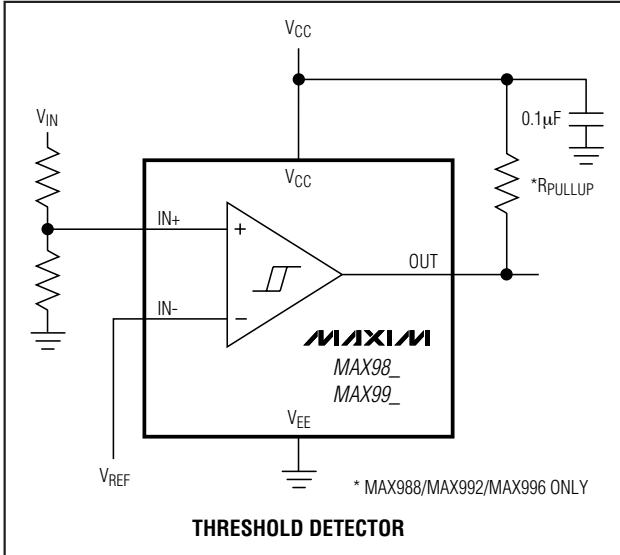

Ordering Information (continued)

PART	PIN-PACKAGE	PKG CODE	TOP MARK
MAX988 EXK-T	5 SC70-5	X5-1	ABN
MAX988EUK-T	5 SOT23-5	U5-1	ABZC
MAX988ESA	8 SO	S8-2	—
MAX991 EKA-T	8 SOT23-8	K8-5	AAEB
MAX991EUA-T	8 µMAX-8	U8-1	—
MAX991ESA	8 SO	S8-2	—
MAX992 EKA-T	8 SOT23-8	K8-5	AAEC
MAX992EUA-T	8 µMAX-8	U8-1	—
MAX992ESA	8 SO	S8-2	—
MAX995 EUD	14 TSSOP	U14-1	—
MAX995ESD	14 SO	S14-4	—
MAX996 EUD	14 TSSOP	U14-1	—
MAX996ESD	14 SO	S14-4	—

Note: All devices specified over the -40°C to +85°C operating temperature range.

Tape-and-Reel Information

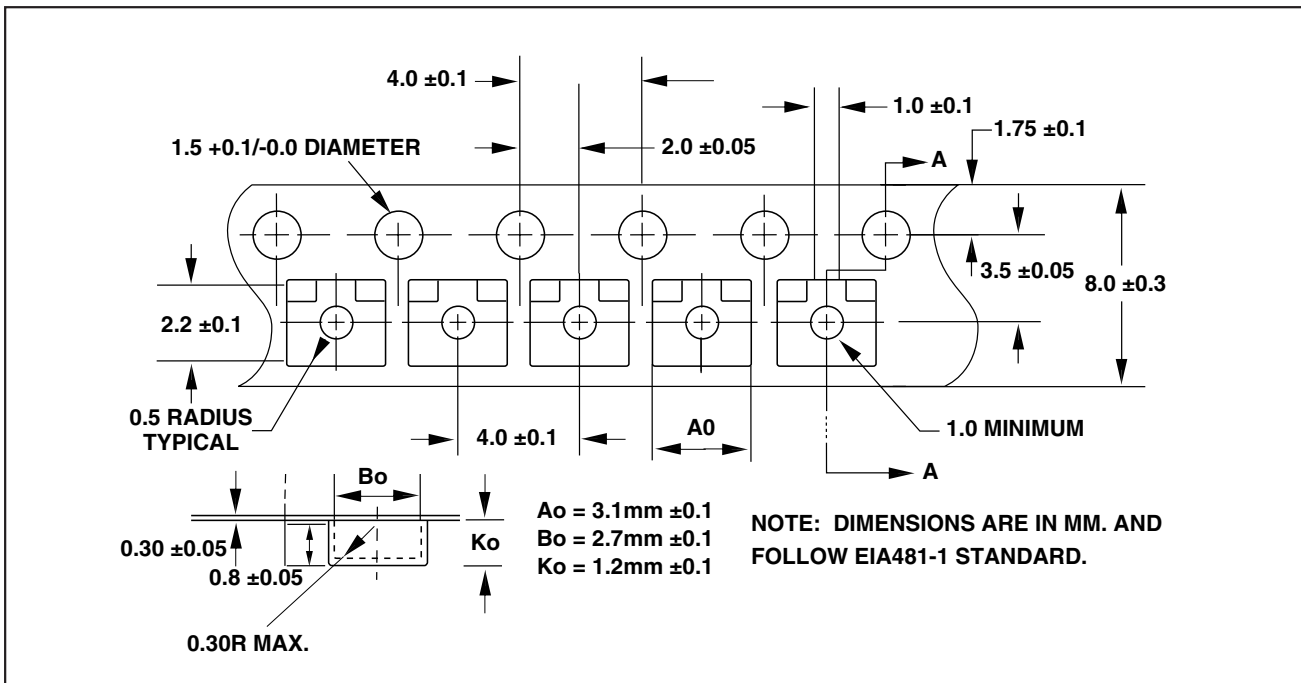

MAX987/MAX988/MAX991/MAX992/MAX995/MAX996

High-Speed, Micropower, Low-Voltage, SOT23, Rail-to-Rail I/O Comparators

Package Information

(The package drawing(s) in this data sheet may not reflect the most current specifications. For the latest package outline information go to www.maxim-ic.com/packages.)

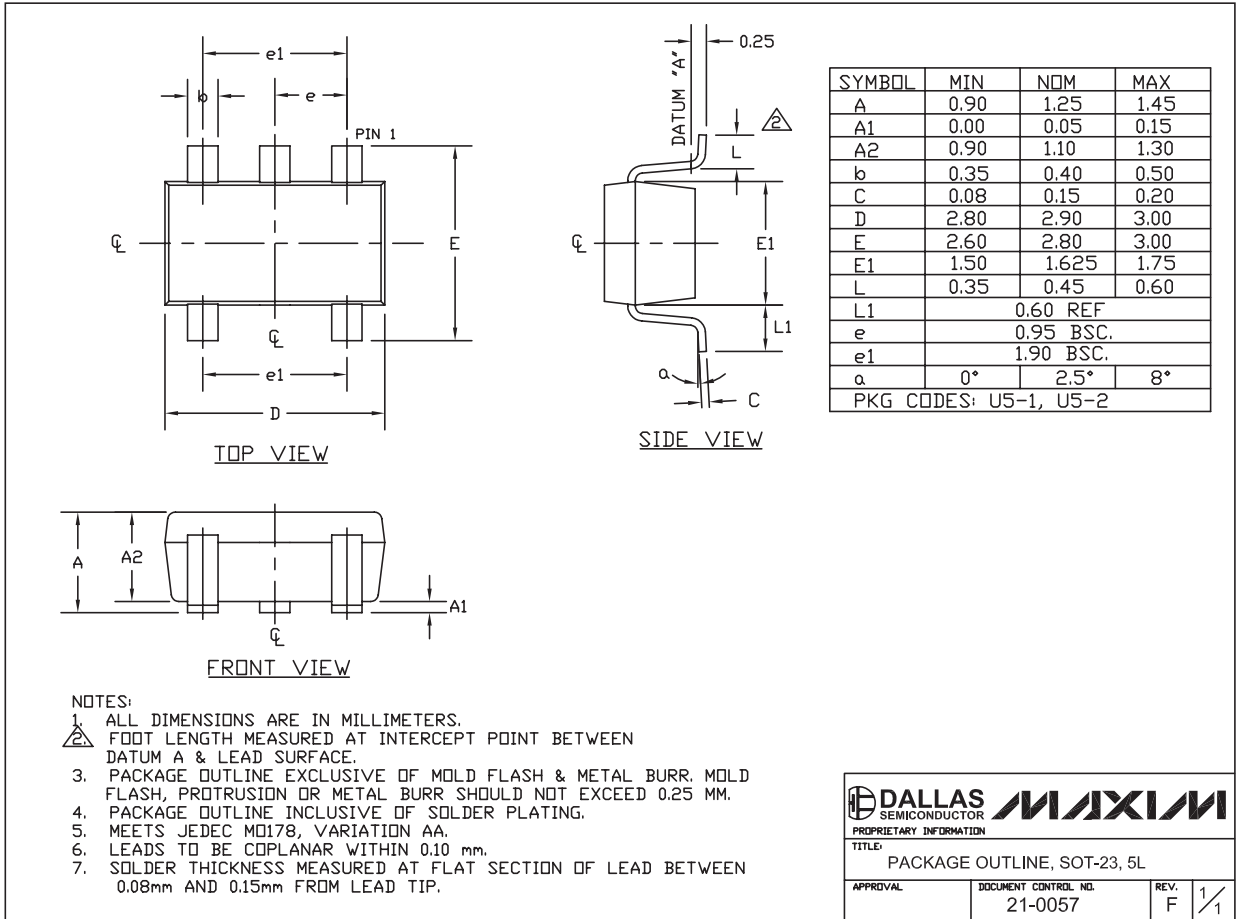

SOT-23 5L.EPS

High-Speed, Micropower, Low-Voltage, SOT23, Rail-to-Rail I/O Comparators

Package Information (continued)

(The package drawing(s) in this data sheet may not reflect the most current specifications. For the latest package outline information go to www.maxim-ic.com/packages.)

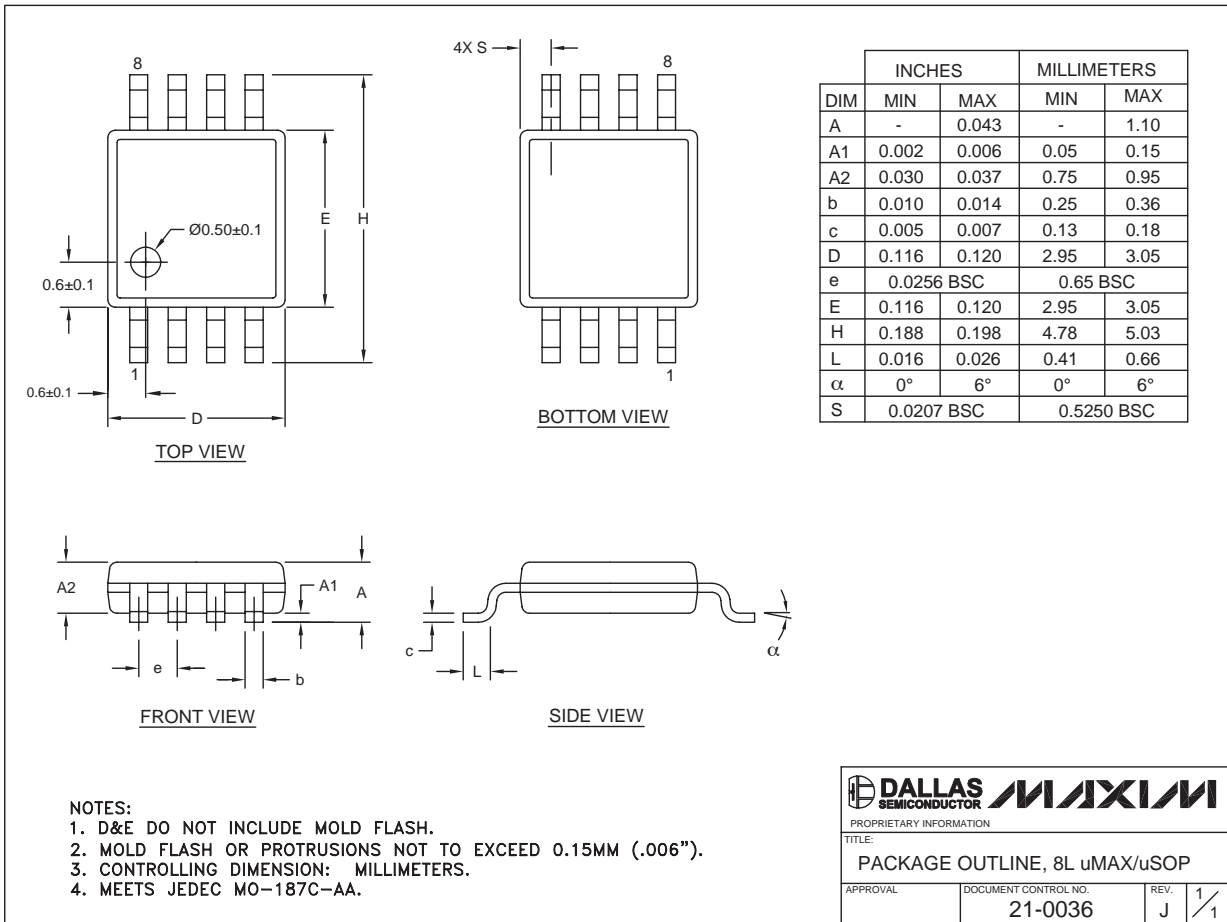

MAX987/MAX988/MAX991/MAX992/MAX995/MAX996

Revision History

Pages changed at Rev 2: 1-6, 8-13

Maxim cannot assume responsibility for use of any circuitry other than circuitry entirely embodied in a Maxim product. No circuit patent licenses are implied. Maxim reserves the right to change the circuitry and specifications without notice at any time.

Maxim Integrated Products, 120 San Gabriel Drive, Sunnyvale, CA 94086 408-737-7600 13