

## **Excellent Integrated System Limited**

Stocking Distributor

Click to view price, real time Inventory, Delivery & Lifecycle Information:

[Hammond Manufacturing](#)  
[1590CF](#)

For any questions, you can email us directly:

[sales@integrated-circuit.com](mailto:sales@integrated-circuit.com)

**Top View of Assembly**

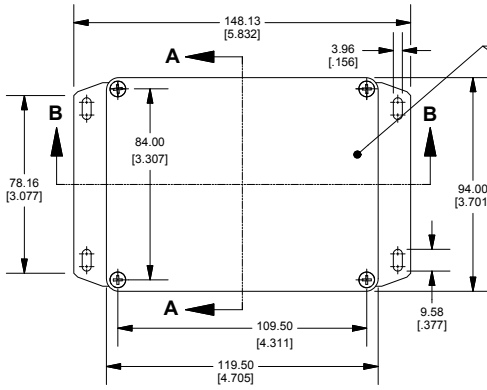

**SECTION A-A  
End View of Assembly**

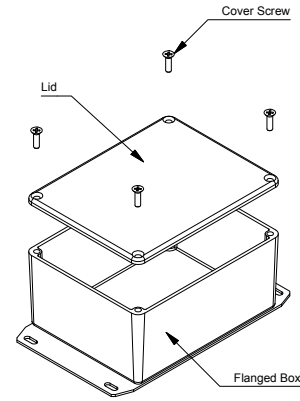
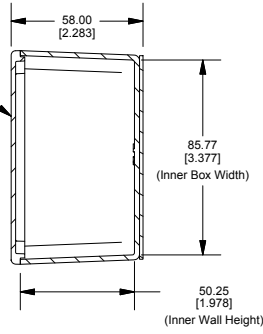

**SECTION B-B  
Side View of Assembly**

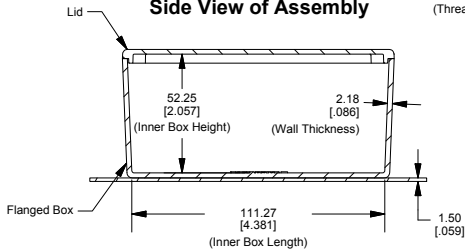

**Top View Looking Inside Box**

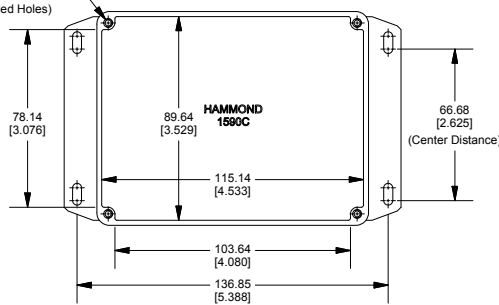

**Lid**

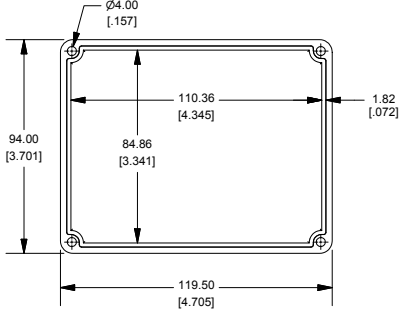

Enclosures can be Factory Modified ( Milling, Drilling, Printing etc.)  
Contact Factory njm@hammondmfg.com for quotes  
Solid models of this enclosure available in STEP or IGES.

**NOTE**

Purchased assembly includes box, lid and 4 cover screws.  
Box and lid are made from Diecast Aluminum Alloy.  
Silicone Gasket supplied with liquid resistant enclosure.  
Bottom Flange is Welded.

**PART NUMBERS**

1590CF Enclosure	
Natural Finish Enclosure	1590CF
Black Textured Enclosure	1590CFBK
1590CF Liquid Resistant Enclosure (Silicone Gasket)	
Natural Finish Enclosure	1590WCF
Black Textured Enclosure	1590WCFBK

**ACCESSORIES**

Recommended Torque: 75 oz.f.in / 55 cN.m

**Liquid Resistant Cover Screws**

Stainless Steel Cover Screws (Pkg 100) [6-32 x 1/2" With O-Ring]	1590WMS100
Black Stainless Steel Cover Screws (Pkg 100) [6-32 x 1/2" With O-Ring]	1590WMS100BK

**Standard Cover Screws**

Plated Cover Screws (Pkg 100) [6-32 x 1/2"]	1590MS100
Black Cover Screws (Pkg 100) [6-32 x 1/2"]	1590MS100BK

Dimensions:  
mm  
[inches]

**HAMMOND  
MANUFACTURING™**  
**1590CF**  
www.hammondmfg.com