

## Excellent Integrated System Limited

Stocking Distributor

Click to view price, real time Inventory, Delivery & Lifecycle Information:

[Hammond Manufacturing](#)  
[1590M](#)

For any questions, you can email us directly:

[sales@integrated-circuit.com](mailto:sales@integrated-circuit.com)

# P.C. Card Guide (1590 Series)

Countersunk lid with machine screws into drilled and tapped holes...

Vibra finished for a smooth surface with no sharp edges...

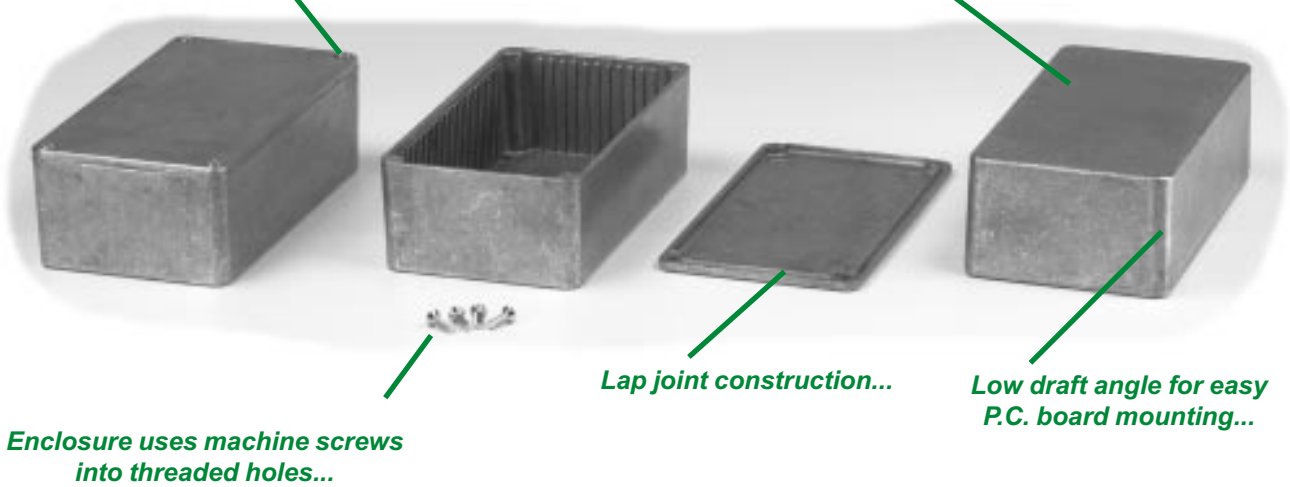

Enclosure uses machine screws into threaded holes...

Lap joint construction...

Low draft angle for easy P.C. board mounting...

Diecast

## OTHER KEY FEATURES

- Rugged, diecast aluminum alloy (tough yet easy to machine), electronic instrument enclosure.
- Lap joint construction provides protection against access of dust and splashing water. Also provides for improved EMI/RFI shielding.
- Painted version is painted with tough powder paint for a lasting finish, even after machining.
- Designed to meet IP54.
- Integral card guides cast in, accept 1.5 mm (0.062") P.C. cards.

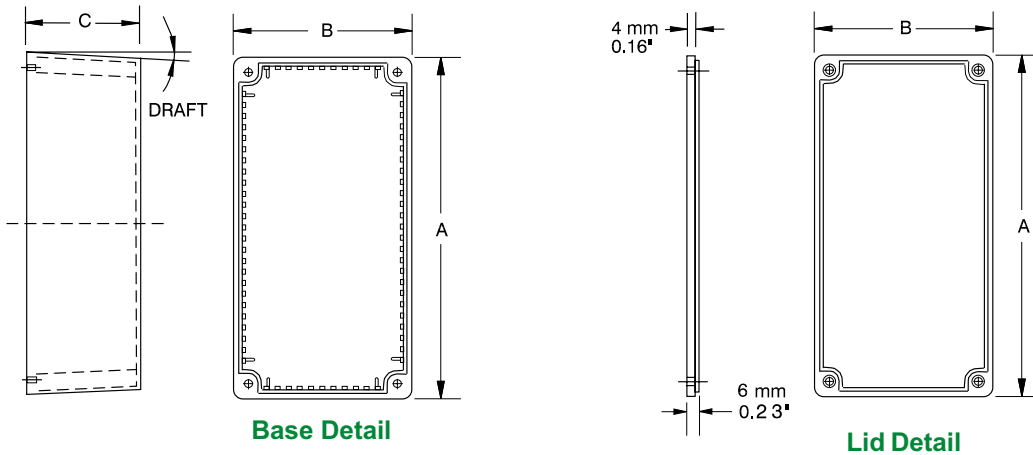

- Notes:**
- Assembled height = dimension "C" + .16" (4.0 mm)
  - Wall & lid thickness is roughly .08" (2 mm) and varies with draft due to part being cast.
  - For detailed drawings, CAD files or color photos visit our website at: [www.hammondmg.com](http://www.hammondmg.com)

## ACCESSORIES



**P.C. Board Card Adaptors**  
 Allows horizontal mounting of P.C. board(s). See "Accessories Section" for full details!  
**1591Z6** - Package of 6  
**1591Z50** - Package of 50  
**1591Z100** - Package of 100



**Replacement Screws**  
 See Parts Table (next page)

# P.C. Card Guide (1590 Series)

## Flanged Version



### KEY FEATURES

- Same as previous page.
- Factory installed flanges.
- Lid screws are exposed for easy enclosure access.
- Designed to meet IP54.

Diecast

## Flanged Lid Version

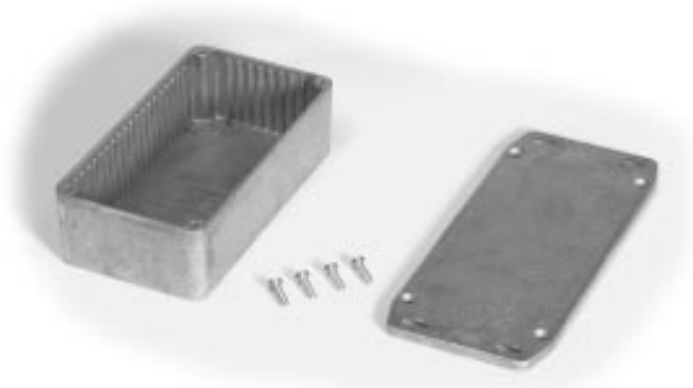

### KEY FEATURES

- Same as previous page.
- Lid screws are hidden against wall or shelf for extra security.
- Designed to meet IP54.

Part Number				Units	Dimensions			Apx. Draft	Screw Thread	Part Number
Unpainted	Black	Flanged (Unpainted)	Flanged Lid (Unpainted)		A	B	C (No Lid)			Replacement Screws (Pkg. 100)
1590L	1590LBK	1590LF	-	inch mm	3.96 101	1.98 50	.83 21	2°	M3-0.5x10mm	1591MS100
1590M	1590MBK	1590MF	-	inch mm	4.48 114	2.49 63	1.06 27	2°	M3-0.5x10mm	1591MS100
1590N	1590NBK	1590NF	1590NFL	inch mm	4.75 121	2.61 66	1.42 36	2°	6-32x1/2"	1590MS100
1590P	1590PBK	1590PF	1590PFL	inch mm	6.01 153	3.24 82	1.81 46	2°	6-32x1/2"	1590MS100
1590R	1590RBK	1590RF	-	inch mm	7.55 192	4.38 111	2.24 57	2°	6-32x1/2"	1590MS100

**Notes:** Assembled height = dimension "C" + .16" (4.0 mm). Wall & lid thickness is roughly .08" (2 mm) and varies with draft due to part being cast. For detailed drawings, CAD files or color photos visit our website at: [www.hammondmfg.com](http://www.hammondmfg.com)



**CANADA**  
 Guelph, Ontario (519) 822-2960  
 St. Laurent, Quebec (514) 343-9010  
**USA**  
 Cheektowaga, NY (716) 651-0086



**EUROPE**  
 Basingstoke, UK +44 1256 812812

**AUSTRALASIA**  
 Queenstown, SA, Australia +61 8 8240 2244

## P.C. Card Guide (1590 Series)

### Watertight Version



#### KEY FEATURES

- Same as previous page.
- Bead of silicone rubber around lid perimeter.
- Designed to meet IP65.
- Painted version uses tough powder paint on exterior only.

Part Number		Units	Dimensions			Apx. Draft
Unpainted	Black		A	B	C (No Lid)	
1590WN	1590WNBK	inch mm	4.75 121	2.61 66	1.42 36	2°
1590WP	1590WPBK	inch mm	6.01 153	3.24 82	1.81 46	2°

Diecast

### Watertight Flanged Lid Version



#### KEY FEATURES

- Same as previous page.
- Lid screws are hidden against wall or shelf for extra security.
- Bead of silicone rubber around lid perimeter.
- Designed to meet IP65.
- Painted version uses tough powder paint on exterior only.

Part Number		Units	Dimensions			Apx. Draft
Unpainted	Black		A	B	C (No Lid)	
1590WNFL	1590WNFLBK	inch mm	4.75 121	2.61 66	1.42 36	2°
1590WPFL	1590WPFLBK	inch mm	6.01 153	3.24 82	1.81 46	2°

### Watertight Flanged Version



#### KEY FEATURES

- Same as previous page.
- Bead of silicone rubber around lid perimeter.
- Designed to meet IP65.
- Painted version uses tough powder paint on exterior only.

Part Number		Units	Dimensions			Apx. Draft
Unpainted	Black		A	B	C (No Lid)	
1590WNF	1590WNFBK	inch mm	4.75 121	2.61 66	1.42 36	2°
1590WPF	1590WPFBK	inch mm	6.01 153	3.24 82	1.81 46	2°