

Excellent Integrated System Limited

Stocking Distributor

Click to view price, real time Inventory, Delivery & Lifecycle Information:

[Bel Fuse Inc.](#)
[VBS10-2021](#)

For any questions, you can email us directly:
sales@integrated-circuit.com

RoHS COMPLIANT

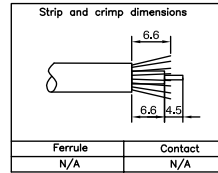
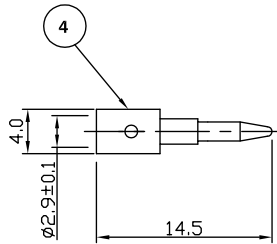
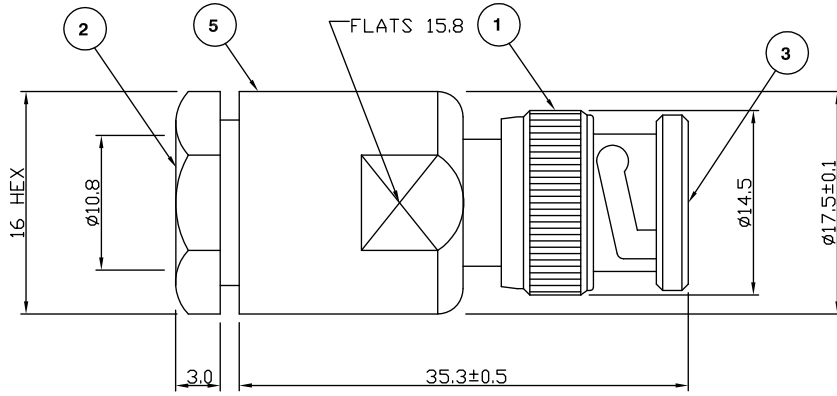

For stripping and assembly instructions see Drawing Number: VAIB1205

Electrical Characteristics

Nominal Impedance:	50 ohms
Frequency Range:	DC to 4 GHz
VSWR:	1.35:1 maximum
Insertion Loss:	0.2 dB at 3 GHz
Operating Voltage (rms):	500 V maximum at sea level
Dielectric Withstand Voltage (rms):	1500 V maximum at sea level
Contact Resistance:	1.5 milliohms maximum
Insulation Resistance:	5000 megohms minimum

Mechanical Characteristics

Mating Cycles:	500 cycles minimum
Interface Dimensions:	Conform to MIL-C-39012

Environmental Characteristics

Temperature Range:	-55 °C to +85 °C
--------------------	------------------

PART	DESCRIPTION
1 Shell	Brass, nickel plated 1.78 μm
2 Clamp Nut	Brass, nickel plated 1.78 μm
3 Dielectric	Delrin, white
4 Contact	Brass, gold plated 0.076 μm - 0.127 μm
5 Body	Brass, nickel plated 1.78 μm

Drawing Update	JT	2	12 May 10
First Issue	JW	1	13 June 06
DESCRIPTION OF REVISION	APPVD	ISS	DATE



Cinch Connectivity Solutions
 7-13 Russel Way,
 Widford Industrial Estate,
 Chelmsford, Essex,
 CM1 3AA, UK.
 Tel: +44 (0) 1245 359515
 Fax: +44 (0) 1245 358938

SCALE: Not To Scale
 DIMENSIONS: mm
 TOLERANCES:
 ± 0.2mm unless
 otherwise stated

DRAWN BY:	J Williams
CHECKED BY:	A Tusi
APPROVED BY:	M Terry
DATE:	13 Jun 06

TITLE:
BNC Clamp Plug for RA519

PART NUMBER:
VBS10-2021

PAGE: 1 of 1