

Excellent Integrated System Limited

Stocking Distributor

Click to view price, real time Inventory, Delivery & Lifecycle Information:

[Maxim Integrated](#)
[MAX4647EUT-T](#)

For any questions, you can email us directly:

sales@integrated-circuit.com



25Ω SPST Analog Switches in SOT23-6

MAX4647/MAX4648

General Description

The MAX4647/MAX4648 are dual-supply single-pole/single-throw (SPST) switches. On-resistance is 25Ω max and flat (2Ω max) over the specified signal range. Each switch can handle rail-to-rail analog signals. Off-leakage current is only 1nA max at +25°C. They conduct analog or digital signals equally well in either direction. The primary application areas are in the switching and routing of signals in telecommunications and test equipment.

The MAX4647/MAX4648 are single SPST analog switches. The MAX4647 has one normally closed (NC) switch, and the MAX4648 has one normally open (NO) switch. These devices operate from a single +9V to +36V supply or from dual ±4.5V to ±20V supplies. The MAX4647/MAX4648 are available in tiny 6-pin SOT23 packages.

Applications

PBX, PABX Systems
 Communication Systems
 DSL
 Test Equipment
 Avionics
 Audio Systems
 Redundant Systems
 Relay Replacement
 PC Multimedia Boards

Features

- ◆ Low On-Resistance 25Ω max (±15V Supplies)
- ◆ Guaranteed RON Flatness Over Specified Signal Range (2Ω max)
- ◆ VL Logic Supply Not Required
- ◆ Rail-to-Rail Signal Handling
- ◆ ±15V and Single 12V Supply Operation
- ◆ Low Leakage (1nA max)
- ◆ Fast Switching Speeds
 $t_{ON} = 100ns$
 $t_{OFF} = 100ns$

Ordering Information

PART	TEMP RANGE	PIN-PACKAGE	TOP MARK	PKG CODE
MAX4647EUT-T+	-40°C to +85°C	6 SOT23	AARV	U6SN-1
MAX4648EUT-T+	-40°C to +85°C	6 SOT23	AARW	U6SN-1

+Denotes a lead-free package.

Pin Configurations/Functional Diagrams/Truth Tables

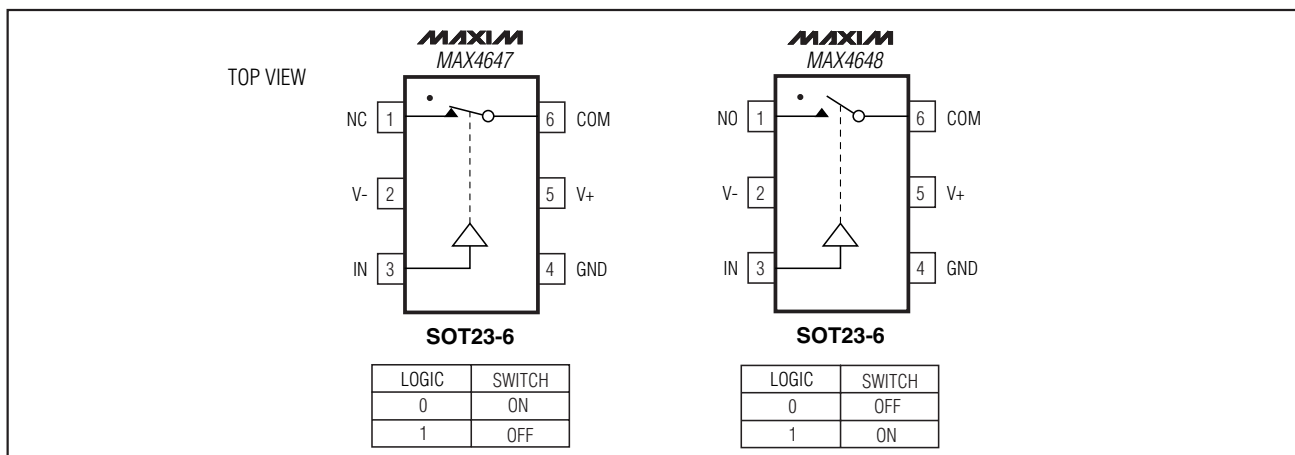

25Ω SPST Analog Switches in SOT23-6

MAX4647/MAX4648

ABSOLUTE MAXIMUM RATINGS

(Voltages referenced to GND)

V+	-0.3V, +44.0V
V-	-44.0V, +0.3V
V+ to V-	-0.3V to +44.0V
All Other Pins (Note 1)	V- - 0.3V to V+ + 0.3V
Continuous Current into Any Terminal	±60mA
Peak Current into Any Terminal (pulsed at 1ms, 10% duty cycle)	±100mA

Continuous Power Dissipation (T_A = +70°C)

6-Pin SOT23 (derate 8.7mW/°C above +70°C)	696mW
Operating Temperature Ranges	
MAX464_EUT	-40°C to +85°C
Storage Temperature Range	-65°C to +150°C
Junction Temperature	+150°C
Lead Temperature (soldering, 10s)	+300°C

Note 1: Signals on NO, NC, COM, or IN exceeding V+ or V- are clamped by internal diodes. Limit forward-diode current to maximum current rating.

Stresses beyond those listed under "Absolute Maximum Ratings" may cause permanent damage to the device. These are stress ratings only, and functional operation of the device at these or any other conditions beyond those indicated in the operational sections of the specifications is not implied. Exposure to absolute maximum rating conditions for extended periods may affect device reliability.

ELECTRICAL CHARACTERISTICS—Dual ±15V Supplies

(V+ = +15V, V- = -15V, V_{IH} = 2.4V, V_{IL} = 0.8V, T_A = T_{MIN} to T_{MAX}, unless otherwise noted. Typical values are at T_A = +25°C.)
 (Notes 2, 3)

PARAMETER	SYMBOL	CONDITIONS	T _A	MIN	TYP	MAX	UNITS
ANALOG SWITCH							
Analog Signal Range	V _{NO} , V _{NC} , V _{COM}			V-		V+	V
On-Resistance	R _{ON}	I _{COM} = 10mA; V _{NO} or V _{NC} = ±10V	+25°C		18	25	Ω
			T _{MIN} to T _{MAX}			30	
On-Resistance Flatness (Note 4)	R _{FLAT(ON)}	I _{COM} = 10mA; V _{NO} or V _{NC} = +5V, 0, -5V	+25°C		0.8	2	Ω
			T _{MIN} to T _{MAX}			3	
NO or NC Off-Leakage Current	I _{NO(OFF)} or I _{NC(OFF)}	V _{NO} or V _{NC} = +14V, -14V; V _{COM} = -14V, +14V	+25°C	-1	0.01	1	nA
			T _{MIN} to T _{MAX}			10	
COM Off-Leakage Current	I _{COM(OFF)}	V _{COM} = -14V, +14V; V _{NO} or V _{NC} = +14V, -14V	+25°C	-1	0.01	1	nA
			T _{MIN} to T _{MAX}			10	
COM On-Leakage Current	I _{COM(ON)}	V _{COM} = +14V, -14V; V _{NO} or V _{NC} = +14V, -14V or floating	+25°C	-2		2	nA
			T _{MIN} to T _{MAX}			20	
LOGIC INPUT							
Input Logic High	V _{IH}		T _{MIN} to T _{MAX}	2.4			V
Input Logic Low	V _{IL}		T _{MIN} to T _{MAX}			0.8	V
Input Leakage Current	I _{IN}	V _{IN} = 0 or +5V	T _{MIN} to T _{MAX}	-1		1	μA
DYNAMIC CHARACTERISTICS							
Turn-On Time	t _{ON}	V _{NO} or V _{NC} = ±10V; R _L = 300Ω; C _L = 35pF; Figure 2	+25°C		68	100	ns
			T _{MIN} to T _{MAX}			125	
Turn-Off Time	t _{OFF}	V _{NO} or V _{NC} = ±10V; R _L = 300Ω; C _L = 35pF; Figure 2	+25°C		62	100	ns
			T _{MIN} to T _{MAX}			125	
Charge Injection	Q	COM = 0; R _S = 0; C _L = 1nF; Figure 3	+25°C		4		pC

25Ω SPST Analog Switches in SOT23-6

ELECTRICAL CHARACTERISTICS—Dual ±15V Supplies (continued)

(V+ = +15V, V- = -15V, V_{IH} = 2.4V, V_{IL} = 0.8V, T_A = T_{MIN} to T_{MAX}, unless otherwise noted. Typical values are at T_A = +25°C. (Notes 2, 3))

PARAMETER	SYMBOL	CONDITIONS	T _A	MIN	TYP	MAX	UNITS
Off-Isolation	V _{ISO}	C _L = 5pF; R _L = 50Ω; f = 1MHz; V _{COM} = 1V _{RMS} ; Figure 4	+25°C		-92		dB
Total Harmonic Distortion	THD	R _L = 600Ω, 5Vp-p, f = 20Hz to 20kHz	+25°C		0.006		%
V _{NO} or V _{NC} Off-Capacitance	C _{NO(OFF)} , C _{NC(OFF)}	f = 1MHz; Figure 5	+25°C		6		pF
COM Off-Capacitance	C _{COM(OFF)}	f = 1MHz; Figure 5	+25°C		6		pF
COM On-Capacitance	C _{COM(ON)}	f = 1MHz; Figure 6	+25°C		19		pF
POWER SUPPLY							
Power Supply Range			T _{MIN} to T _{MAX}	±4.5		±20	V
Positive Supply Current	I+	V _{IN} = 5V	+25°C		45	100	μA
			T _{MIN} to T _{MAX}			150	
		V _{IN} = 0 or V+	+25°C		0.001	1	
			T _{MIN} to T _{MAX}			10	
Negative Supply Current	I-	V _{IN} = 0 or 5V	+25°C		0.001	1	μA
			T _{MIN} to T _{MAX}			10	

ELECTRICAL CHARACTERISTICS—Single +12V Supply

(V+ = +12V, V- = 0, V_{IH} = 2.4V, V_{IL} = 0.8V, T_A = T_{MIN} to T_{MAX}, unless otherwise noted. Typical values are at T_A = +25°C. (Notes 2, 3))

PARAMETER	SYMBOL	CONDITIONS	T _A	MIN	TYP	MAX	UNITS
ANALOG SWITCH							
Analog Signal Range	V _{NO} , V _{NC} , V _{COM}			0		V+	V
On-Resistance	R _{ON}	I _{COM} = 10mA; V _{NO} or V _{NC} = +10V	+25°C		36	45	Ω
			T _{MIN} to T _{MAX}			60	
On-Resistance Flatness (Note 4)	R _{FLAT(ON)}	I _{COM} = 10mA; V _{NO} or V _{NC} = +2V, +6V, +10V	+25°C		4	6	Ω
			T _{MIN} to T _{MAX}			8	
DYNAMIC							
Turn-On Time	t _{ON}	V _{NO} or V _{NC} = +10V; R _L = 300Ω; C _L = 35pF; Figure 2	+25°C		100	175	ns
			T _{MIN} to T _{MAX}			225	
Turn-Off Time	t _{OFF}	V _{NO} or V _{NC} = +10V; R _L = 300Ω; C _L = 35pF; Figure 2	+25°C		68	150	ns
			T _{MIN} to T _{MAX}			200	
Charge Injection	Q	COM = 0; R _S = 0; C _L = 1nF; Figure 3	+25°C		-5		pC

25Ω SPST Analog Switches in SOT23-6

ELECTRICAL CHARACTERISTICS—Single +12V Supply (continued)

($V_+ = +12V$, $V_- = 0$, $V_{IH} = 2.4V$, $V_{IL} = 0.8V$, $T_A = T_{MIN}$ to T_{MAX} , unless otherwise noted. Typical values are at $T_A = +25^\circ C$.)
 (Notes 2, 3)

PARAMETER	SYMBOL	CONDITIONS	T_A	MIN	TYP	MAX	UNITS
Power Supply Range			T_{MIN} to T_{MAX}	+9		+36	V
Positive Supply Current	I+	$V_{IN} = 5V$	$+25^\circ C$		20	50	μA
			T_{MIN} to T_{MAX}			75	
		$V_{IN} = 0$ or V_+	$+25^\circ C$		0.001	1	
			T_{MIN} to T_{MAX}			10	

Note 2: The algebraic convention is used in this data sheet; the most negative value is shown in the minimum column.

Note 3: SOT packaged parts are 100% tested at $+25^\circ C$. Limits across the full temperature range are guaranteed by design and correlation.

Note 4: Flatness is defined as the difference between the maximum and minimum value of on-resistance as measured over the specified analog signal range.

Typical Operating Characteristics

($T_A = +25^\circ C$, unless otherwise noted.)

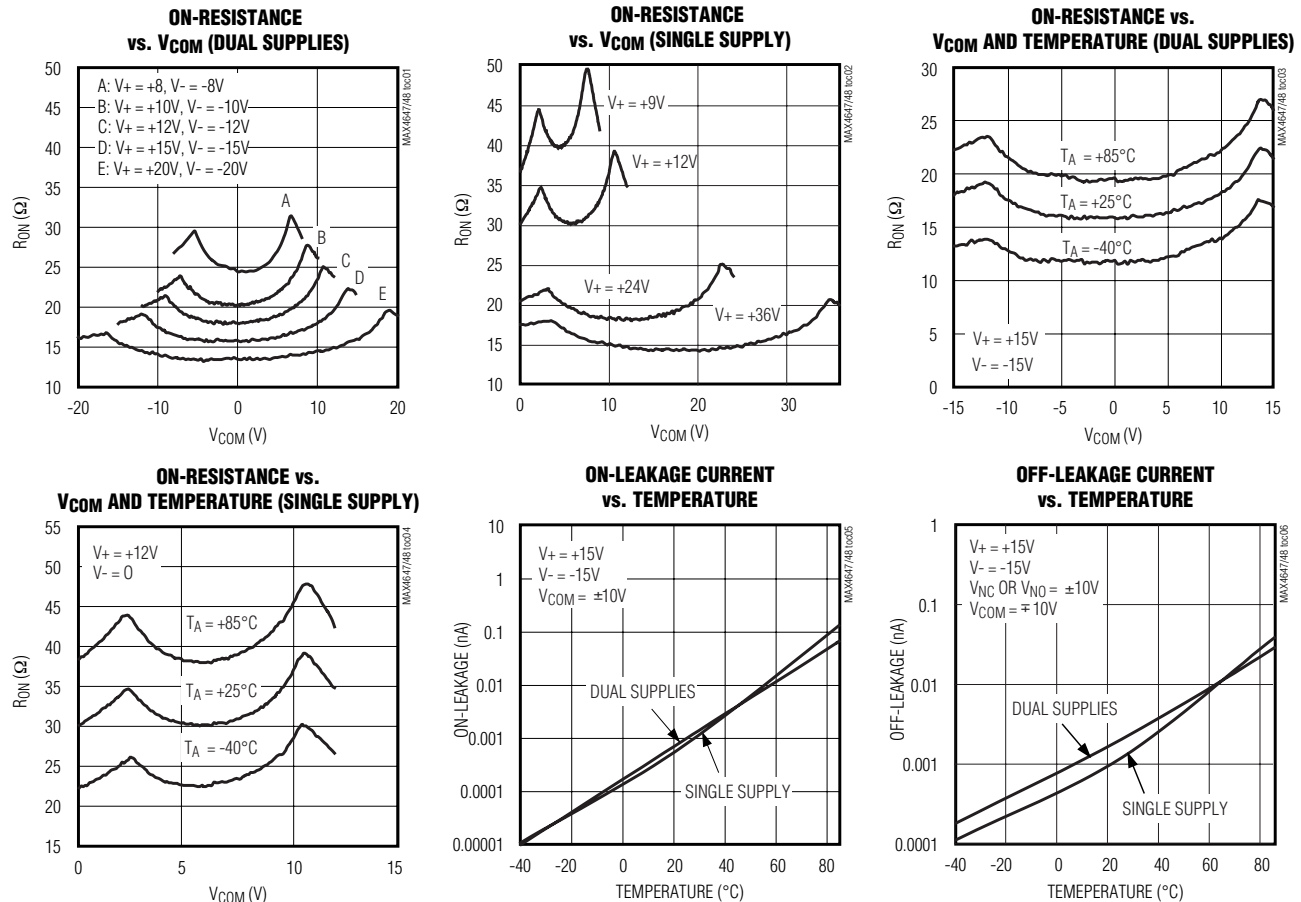

25Ω SPST Analog Switches in SOT23-6

Typical Operating Characteristics (continued)

(T_A = +25°C, unless otherwise noted.)

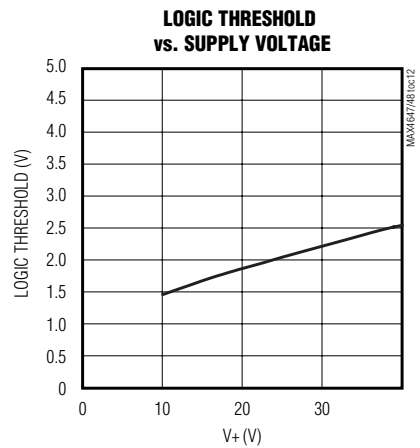
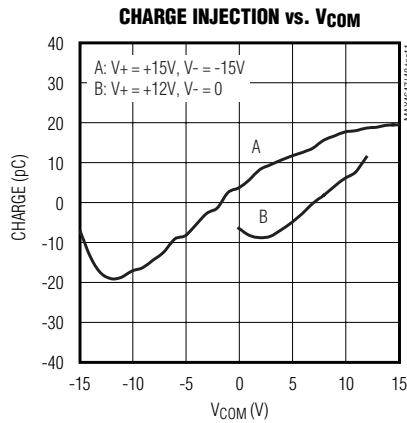
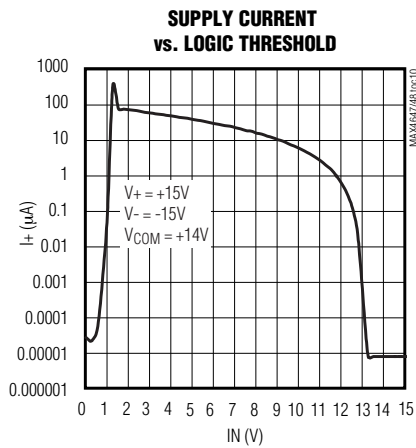
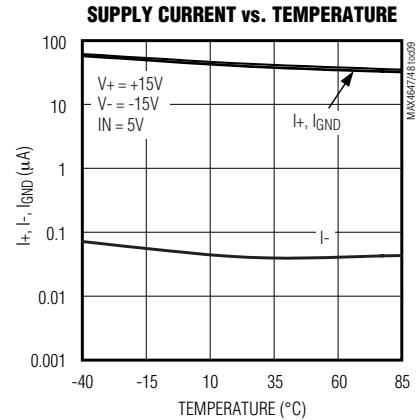
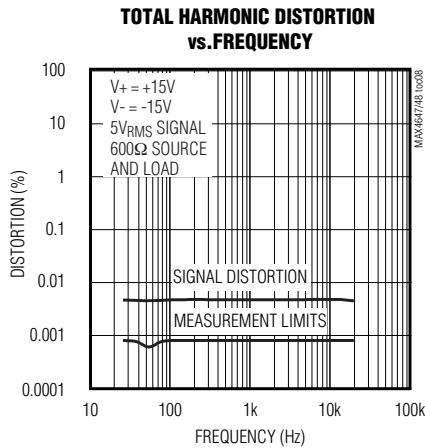
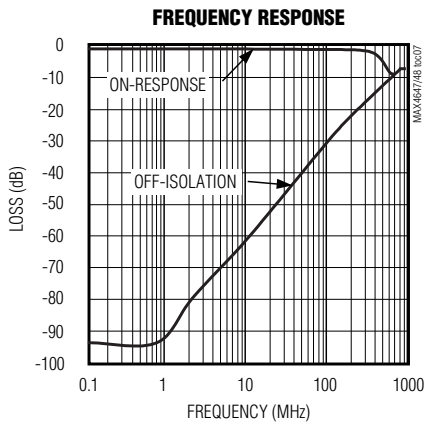

MAX4647/MAX4648

Pin Description

MAX4647	MAX4648	PIN NAME	FUNCTION
1	—	NC	Normally Closed Switch Terminal
—	1	NO	Normally Open Switch Terminal
2	2	V-	Negative Supply Voltage Input
3	3	IN	Digital Control Input
4	4	GND	Ground
5	5	V+	Positive Supply Voltage Input
6	6	COM	Analog Switch Common

25Ω SPST Analog Switches in SOT23-6

Applications Information

Overvoltage Protection

Proper power-supply sequencing is recommended for all CMOS devices. Do not exceed the absolute maximum ratings because stresses beyond the listed ratings can cause permanent damage to the devices. Always sequence V+ on first, then V-, followed by the logic inputs, NO, NC, or COM. If power-supply sequencing is not possible, add two small signal diodes (D1, D2) in series with supply pins (Figure 1). Adding diodes reduces the analog signal range to one diode drop below V+ and one diode drop above V-, but does not affect the devices' low switch resistance and low leakage characteristics. Device operation is unchanged, and the difference between V+ and V- should not exceed 44V. These protection diodes are not recommended when using a single supply.

Off-Isolation at High Frequencies

In 50Ω systems, the high-frequency on-response of these parts extends from DC to above 300MHz, with a typical loss of -2dB. When the switch is turned off, however, it behaves like a capacitor, and off-isolation decreases with increasing frequency. This effect is

more pronounced with higher source and load impedances. Above 5MHz, circuit board layout becomes critical. The graphs shown in the *Typical Operating Characteristics* were taken using a 50Ω source and load connected with BNC connectors.

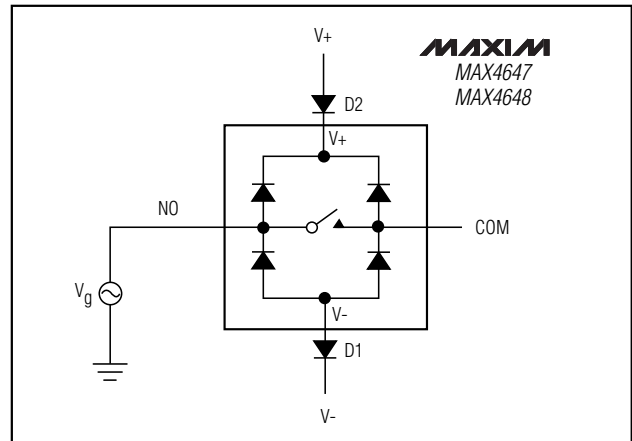

Figure 1. Overvoltage Protection Using External Blocking Diodes

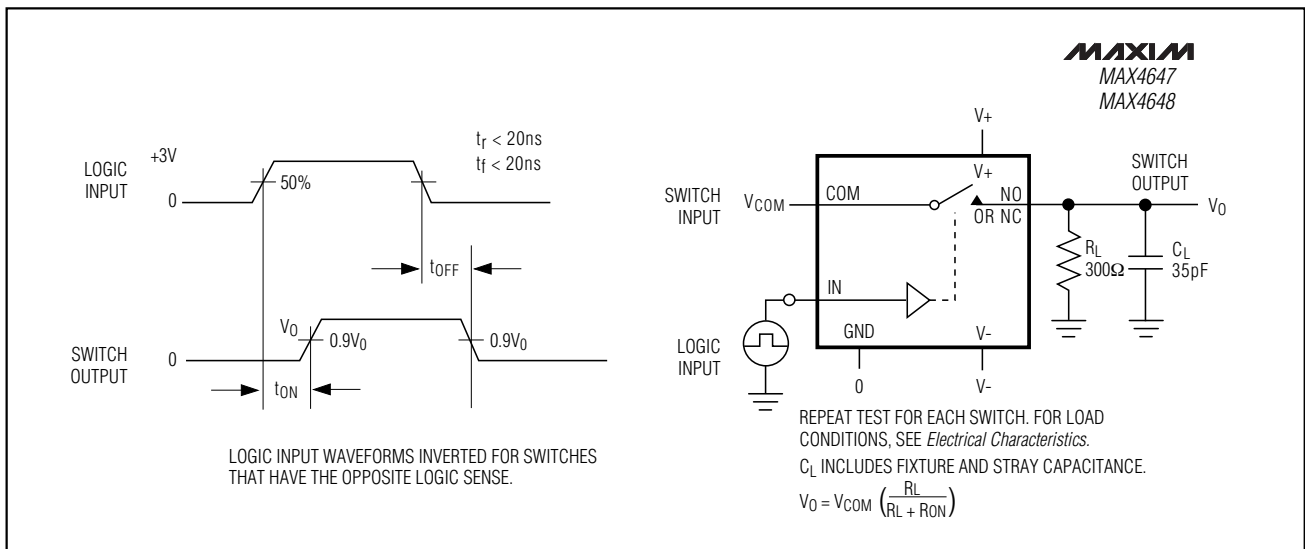

Figure 2. Switching-Time Test Circuit

25Ω SPST Analog Switches in SOT23-6

MAX4647/MAX4648

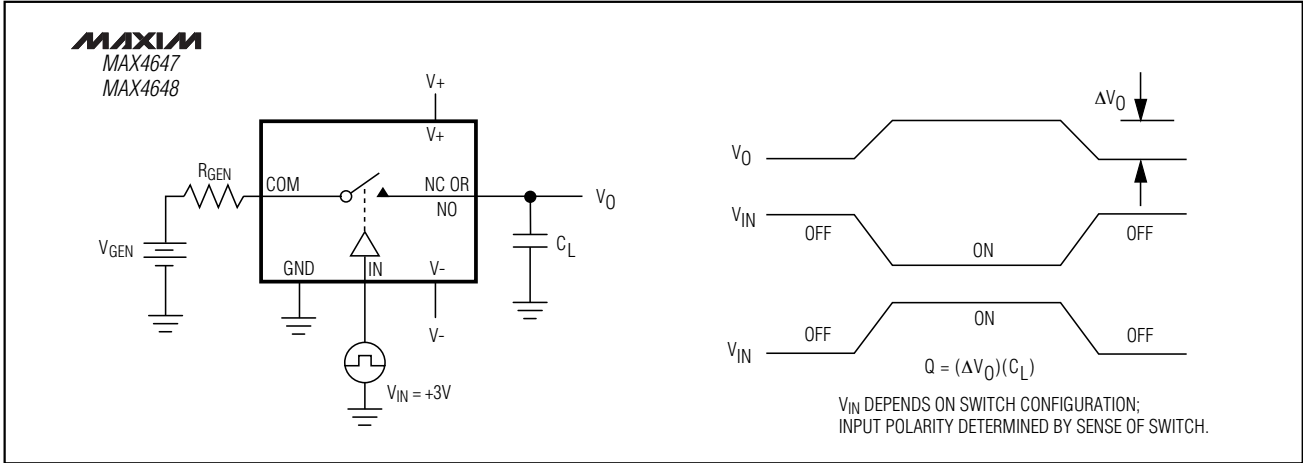

Figure 3. Charge Injection Test Circuit

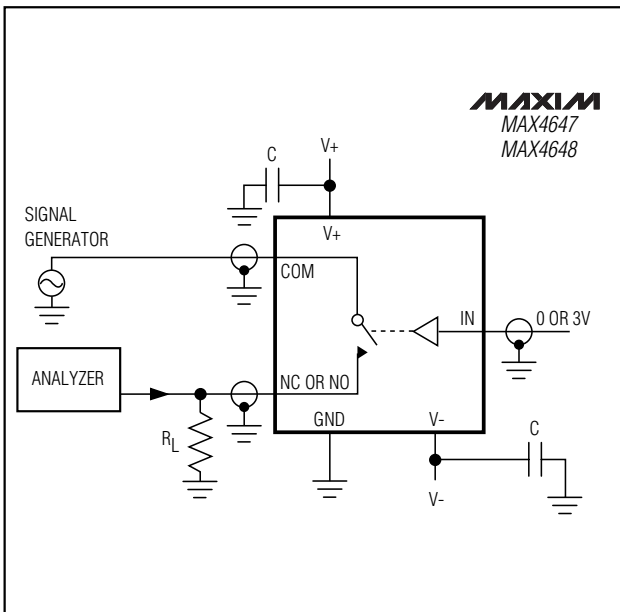

Figure 4. Off-Isolation Test Circuit

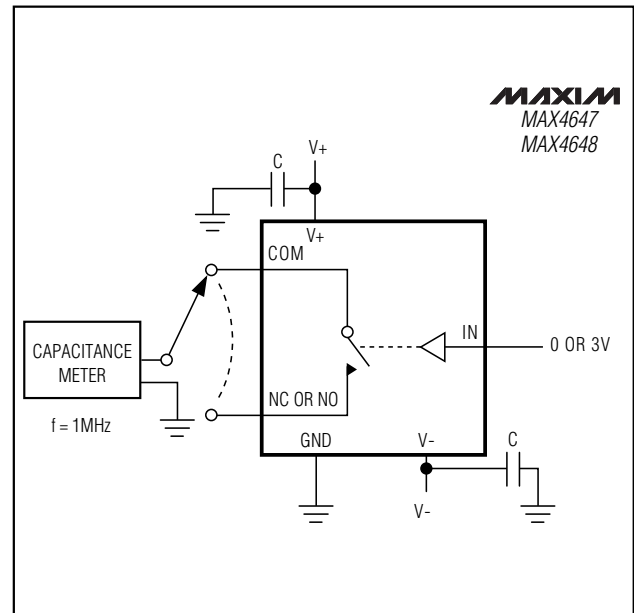

Figure 5. Channel-Off Capacitance Test Circuit

25Ω SPST Analog Switches in SOT23-6

MAX4647/MAX4648

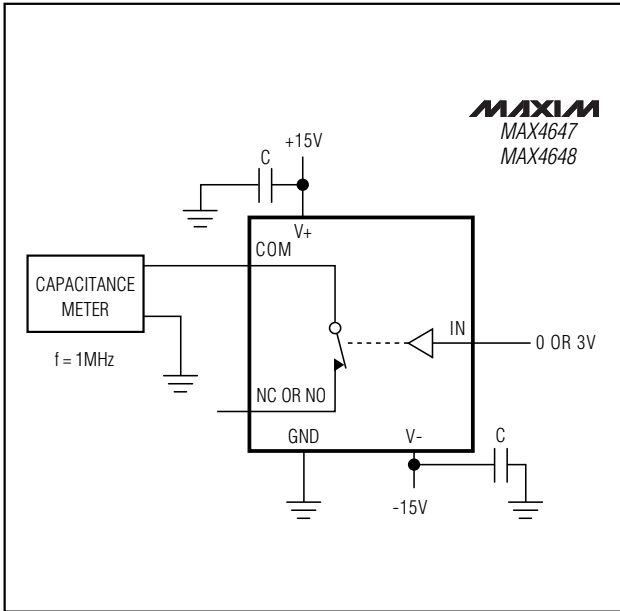

Figure 6. Channel-On Capacitance Test Circuit

Chip Information

TRANSISTOR COUNT: 24

PROCESS TECHNOLOGY: CMOS

25Ω SPST Analog Switches in SOT23-6

Package Information

(The package drawing(s) in this data sheet may not reflect the most current specifications. For the latest package outline information, go to www.maxim-ic.com/packages.)

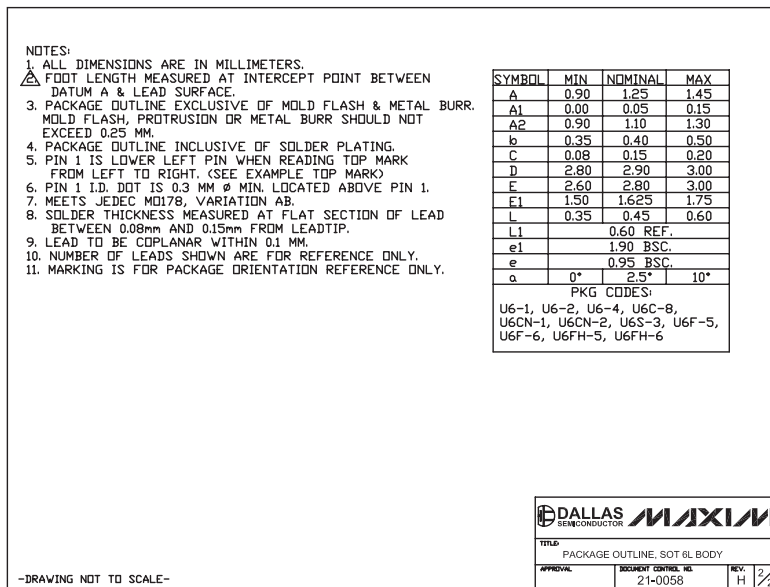
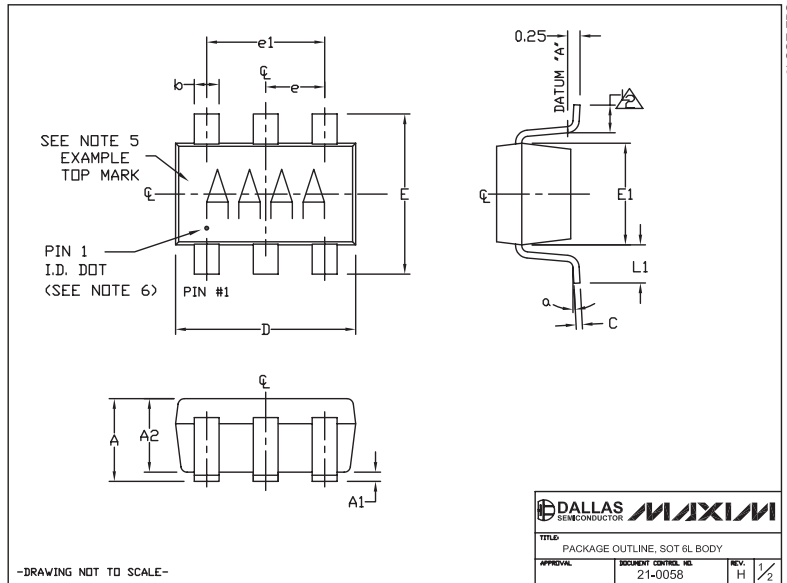

Revision History

Pages changed at Rev 1: 1, 9

Maxim cannot assume responsibility for use of any circuitry other than circuitry entirely embodied in a Maxim product. No circuit patent licenses are implied. Maxim reserves the right to change the circuitry and specifications without notice at any time.

Maxim Integrated Products, 120 San Gabriel Drive, Sunnyvale, CA 94086 408-737-7600 9