

Excellent Integrated System Limited

Stocking Distributor

Click to view price, real time Inventory, Delivery & Lifecycle Information:

[Maxim Integrated](#)
[MAX4664CPE](#)

For any questions, you can email us directly:

sales@integrated-circuit.com

MAXIM

5Ω, Quad, SPST, CMOS Analog Switches

MAX4664/MAX4665/MAX4666

General Description

The MAX4664/MAX4665/MAX4666 quad analog switches feature 5Ω max on-resistance. On-resistance is matched between switches to 0.5Ω max and is flat (0.5Ω max) over the specified signal range. Each switch can handle Rail-to-Rail® analog signals. The off-leakage current is only 5nA max at +85°C. These analog switches are ideal in low-distortion applications and are the preferred solution over mechanical relays in automatic test equipment or in applications where current switching is required. They have low power requirements, require less board space, and are more reliable than mechanical relays.

The MAX4664 has four normally closed (NC) switches, the MAX4665 has four normally open (NO) switches, and the MAX4666 has two NC and two NO switches that guarantee break-before-make switching times.

These switches operate from a single +4.5V to +36V supply or from dual ±4.5V to ±20V supplies. All digital inputs have +0.8V and +2.4V logic thresholds, ensuring TTL/CMOS-logic compatibility when using ±15V supplies or a single +12V supply.

Applications

Reed Relay Replacement	PBX, PABX Systems
Test Equipment	Audio-Signal Routing
Communication Systems	Avionics

Features

- ♦ Low On-Resistance (5Ω max)
- ♦ Guaranteed R_{ON} Match Between Channels (0.5Ω max)
- ♦ Guaranteed R_{ON} Flatness over Specified Signal Range (0.5Ω max)
- ♦ Guaranteed Break-Before-Make (MAX4666)
- ♦ Rail-to-Rail Signal Handling
- ♦ Guaranteed ESD Protection > 2kV per Method 3015.7
- ♦ +4.5V to +36V Single-Supply Operation
±4.5V to ±20V Dual-Supply Operation
- ♦ TTL/CMOS-Compatible Control Inputs

Ordering Information

PART	TEMP. RANGE	PIN-PACKAGE
MAX4664CSE	0°C to +70°C	16 Narrow SO
MAX4664CPE	0°C to +70°C	16 Plastic DIP
MAX4664ESE	-40°C to +85°C	16 Narrow SO
MAX4664EPE	-40°C to +85°C	16 Plastic DIP

Ordering Information continued at end of data sheet.

Pin Configurations/Functional Diagrams/Truth Tables

TOP VIEW

SO/DIP

MAX4664	
LOGIC	SWITCH
0	ON
1	OFF

SO/DIP

MAX4665	
LOGIC	SWITCH
0	OFF
1	ON

SO/DIP

MAX4666		
LOGIC	SWITCHES 1, 4	SWITCHES 2, 3
0	OFF	ON
1	ON	OFF

SWITCHES SHOWN FOR LOGIC "0" INPUT

Rail-to-Rail is a registered trademark of Nippon Motorola, Ltd.

5Ω, Quad, SPST, CMOS Analog Switches

ABSOLUTE MAXIMUM RATINGS

V+ to GND	-0.3V to +44V	Continuous Power Dissipation (TA = +70°C)	
V- to GND	+0.3V to -44V	Narrow SO (derate 8.70mW/°C above +70°C)	696mW
V+ to V-	-0.3V to +44V	Plastic DIP (derate 10.53mW/°C above +70°C)	842mW
VL to GND	(GND - 0.3V) to (V+ + 0.3V)	Operating Temperature Ranges	
All Other Pins to DGND (Note 1)	(V- - 0.3V) to (V+ + 0.3V)	MAX466_C_E	0°C to +70°C
Continuous Current (COM_, NO_, NC_)	±100mA	MAX466_E_E	-40°C to +85°C
Peak Current (COM_, NO_, NC_)	±300mA	Storage Temperature Range	-65°C to +150°C
(pulsed at 1ms, 10% duty cycle)	±300mA	Lead Temperature (soldering, 10sec)	+300°C

Note 1: Signals on NC_, NO_, COM_, or IN_ exceeding V+ or V- are clamped by internal diodes. Limit forward-diode current to maximum current rating.

Stresses beyond those listed under "Absolute Maximum Ratings" may cause permanent damage to the device. These are stress ratings only, and functional operation of the device at these or any other conditions beyond those indicated in the operational sections of the specifications is not implied. Exposure to absolute maximum rating conditions for extended periods may affect device reliability.

ELECTRICAL CHARACTERISTICS—Dual Supplies

(V+ = +15V, V- = -15V, VL = +5V, VIN_H = +2.4V, VIN_L = +0.8V, TA = TMIN to TMAX, unless otherwise noted. Typical values are at TA = +25°C.) (Note 2)

PARAMETER	SYMBOL	CONDITIONS	MIN	TYP	MAX	UNITS	
ANALOG SWITCH							
Input Voltage Range (Note 3)	VCOM_, VNO_, VNC_		V-		V+	V	
COM_ to NO_ or NC_ On-Resistance	RON	ICOM_ = 10mA, VNO_ or VNC_ = ±10V	TA = +25°C	3	4	Ω	
			TA = TMIN to TMAX		5		
COM_ to NO_ or NC_ On-Resistance Match Between Channels (Notes 3, 4)	ΔRON	ICOM_ = 10mA, VNO_ or VNC_ = ±10V	TA = +25°C	0.2	0.5	Ω	
			TA = TMIN to TMAX		0.7		
COM_ to NO_ or NC_ On-Resistance Flatness (Notes 3, 5)	RFLAT(ON)	ICOM_ = 10mA; VNO_ or VNC_ = -5V, 0, 5V	TA = +25°C	0.2	0.5	Ω	
			TA = TMIN to TMAX		0.6		
Off-Leakage Current (NO_ or NC_) (Note 6)	INO_, INC_	VCOM_ = ±10V, VNO_ or VNC_ = ∓10V	TA = +25°C	-0.5	0.01	0.5	nA
			TA = TMIN to TMAX	-5		5	
COM_ Off-Leakage Current (Note 6)	ICOM_(OFF)	VCOM_ = ±10V, VNO_ or VNC_ = ∓10V	TA = +25°C	-0.5	0.01	0.5	nA
			TA = TMIN to TMAX	-5		5	
COM_ On-Leakage Current (Note 6)	ICOM_(ON)	VCOM_ = ±10V, VNO_ or VNC_ = ±10V or floating	TA = +25°C	-1	0.02	1	nA
			TA = TMIN to TMAX	-10		10	
LOGIC INPUT							
Input Current with Input Voltage High	IIH	IN_ = 2.4V, all others = 0.8V	-0.500	0.001	0.500	μA	
Input Current with Input Voltage Low	IL	IN_ = 0.8V, all others = 2.4V	-0.500	0.001	0.500	μA	
Logic Input Voltage High	VIN_H		2.4			V	
Logic Input Voltage Low	VIN_L				0.8	V	

5Ω, Quad, SPST, CMOS Analog Switches

MAX4664/MAX4665/MAX4666

ELECTRICAL CHARACTERISTICS—Dual Supplies (continued)

(V+ = +15V, V- = -15V, VL = +5V, VIN_H = +2.4V, VIN_L = +0.8V, TA = TMIN to TMAX, unless otherwise noted. Typical values are at TA = +25°C.) (Note 2)

PARAMETER	SYMBOL	CONDITIONS	MIN	TYP	MAX	UNITS
POWER SUPPLY						
Power-Supply Range			±4.5		±20.0	V
Positive Supply Current	I+	VIN = 0 or 5V	TA = +25°C TA = TMIN to TMAX	-0.5 0.001	0.5 5	μA
Negative Supply Current	I-	VIN = 0 or 5V	TA = +25°C TA = TMIN to TMAX	-0.5 -5	0.001 5	μA
Logic Supply Current	IL	VIN = 0 or 5V	TA = +25°C TA = TMIN to TMAX	-0.5 -5	0.001 5	μA
Ground Current	IGND	VIN = 0 or 5V	TA = +25°C TA = TMIN to TMAX	-0.5 -5	0.001 5	μA
SWITCH DYNAMIC CHARACTERISTICS						
Turn-On Time	tON	Figure 2, VCOM_ = ±10V	TA = +25°C TA = TMIN to TMAX	130	275 400	ns
Turn-Off Time	tOFF	Figure 2, VCOM_ = ±10V	TA = +25°C TA = TMIN to TMAX	90	175 300	ns
Break-Before-Make Time Delay (MAX4666)		VCOM = 10V		5	30	ns
Charge Injection	Q	CL = 1.0nF, VGEN = 0, RGEN = 0, Figure 3		300		pC
Off-Isolation (Note 7)	VISO	RL = 50Ω, CL = 5pF, f = 1MHz, Figure 4		-62		dB
Crosstalk (Note 8)	VCT	RL = 50Ω, CL = 5pF, f = 1MHz, Figure 5		-60		dB
NC or NO Capacitance	COFF	f = 1MHz, Figure 6		34		pF
COM Off-Capacitance	CCOM	f = 1MHz, Figure 6		34		pF
On-Capacitance	CCOM	f = 1MHz, Figure 7		150		pF

5Ω, Quad, SPST, CMOS Analog Switches

MAX4664/MAX4665/MAX4666

ELECTRICAL CHARACTERISTICS—Single Supply

(V+ = +12V, V- = 0, VL = +5V, VIN_H = +2.4V, VIN_L = +0.8V, TA = TMIN to TMAX, unless otherwise noted. Typical values are at TA = +25°C.) (Note 2)

PARAMETER	SYMBOL	CONDITIONS	MIN	TYP	MAX	UNITS	
ANALOG SWITCH							
Input Voltage Range (Note 3)	VCOM_, VNO_, VNC_		0		V+	V	
COM_ to NO_ or NC_ On-Resistance	RON	ICOM_ = 10mA, VNO_ or VNC_ = 10V	TA = +25°C	5.5	8	Ω	
			TA = TMIN to TMAX		10		
COM_ to NO_ or NC_ On-Resistance Match Between Channels (Notes 3, 4)	ΔRON	ICOM_ = 10mA, VNO_ or VNC_ = 10V	TA = +25°C	0.05	0.5	Ω	
			TA = TMIN to TMAX		0.7		
COM_ to NO_ or NC_ On-Resistance Flatness (Notes 3, 5)	RFLAT(ON)	ICOM_ = 10mA; VNO_ or VNC_ = 3V, 6V, 9V	TA = +25°C	0.25	1.1	Ω	
			TA = TMIN to TMAX		1.2		
Off-Leakage Current (NO_ or NC_) (Notes 6, 9)	INO_, INC_	VCOM_ = 1V, 10V; VNO_ or VNC_ = 10V, 1V	TA = +25°C	-0.5	0.01	0.5	nA
			TA = TMIN to TMAX	-5		5	
COM_ Off-Leakage Current (Notes 6, 9)	ICOM_(OFF)	VCOM_ = 1V, 10V; VNO_ or VNC_ = 10V	TA = +25°C	-0.5	0.01	0.5	nA
			TA = TMIN to TMAX	-5		5	
COM_ On-Leakage Current (Notes 6, 9)	ICOM_(ON)	VCOM_ = 1V, 10V; VNO_ or VNC_ = 1V, 10V or floating	TA = +25°C	-1	0.02	1	nA
			TA = TMIN to TMAX	-10		10	
LOGIC INPUT							
Input Current with Input Voltage High	IIN_H	IN_ = 2.4V, all others = 0.8V	-0.5	0.001	0.5	μA	
Input Current with Input Voltage Low	IIN_L	IN_ = 0.8V, all others = 2.4V	-0.5	0.001	0.5	μA	
Logic Input Voltage High	VIN_H		2.4			V	
Logic Input Voltage Low	VIN_L				0.8	V	
POWER SUPPLY							
Power-Supply Range			4.5		36.0	V	
Positive Supply Current	I+	VIN = 0 or 5V	TA = +25°C	-0.5	0.001	0.5	μA
			TA = TMIN to TMAX	-5		5	
Logic Supply Current	IL	VIN = 0 or 5V	TA = +25°C	-0.5	0.001	0.5	μA
			TA = TMIN to TMAX	-5		5	
Ground Current	IGND	VIN = 0 or 5V	TA = +25°C	-0.5	0.001	0.5	μA
			TA = TMIN to TMAX	-5		5	

5Ω, Quad, SPST, CMOS Analog Switches

MAX4664/MAX4665/MAX4666

ELECTRICAL CHARACTERISTICS—Single Supply (continued)

(V+ = +12V, V- = 0, VL = +5V, VIN_H = +2.4V, VIN_L = +0.8V, TA = TMIN to TMAX, unless otherwise noted. Typical values are at TA = +25°C.)
 (Note 2)

PARAMETER	SYMBOL	CONDITIONS	MIN	TYP (Note 2)	MAX	UNITS
SWITCH DYNAMIC CHARACTERISTICS						
Turn-On Time (Note 3)	tON	Figure 2, VCOM_ = 10V	TA = +25°C	225	400	ns
			TA = TMIN to TMAX		500	
Turn-Off Time (Note 3)	tOFF	Figure 2, VCOM_ = 10V	TA = +25°C	100	250	ns
			TA = TMIN to TMAX		350	
Break-Before-Make Time Delay (MAX4666)		VCOM = 10V	10	125		ns
Charge Injection	Q	CL = 1.0nF, VGEN = 0, RGEN = 0, Figure 3		25		pC
Crosstalk (Note 8)	VCT	RL = 50Ω, CL = 5pF, f = 1MHz, Figure 5		-60		dB
NC_ or NO_ Capacitance	COFF	f = 1MHz, Figure 6		52		pF
COM_Off-Capacitance	CCOM	f = 1MHz, Figure 6		52		pF
On-Capacitance	CCOM	f = 1MHz, Figure 7		100		pF

Note 2: The algebraic convention, where the most negative value is a minimum and the most positive value a maximum, is used in this data sheet.

Note 3: Guaranteed by design.

Note 4: ΔRON = RON(MAX) - RON(MIN).

Note 5: Flatness is defined as the difference between the maximum and minimum value of on-resistance as measured over the specified analog signal range.

Note 6: Leakage parameters are 100% tested at maximum-rated hot temperature and guaranteed by correlation at +25°C.

Note 7: Off-isolation = 20log₁₀ [VCOM_ / (VNC_ or VNO_)], VCOM_ = output, VNC_ or VNO_ = input to off switch.

Note 8: Between any two switches.

Note 9: Leakage testing at single supply is guaranteed by testing with dual supplies.

5Ω, Quad, SPST, CMOS Analog Switches

Typical Operating Characteristics

($T_A = +25^\circ\text{C}$, unless otherwise noted.)

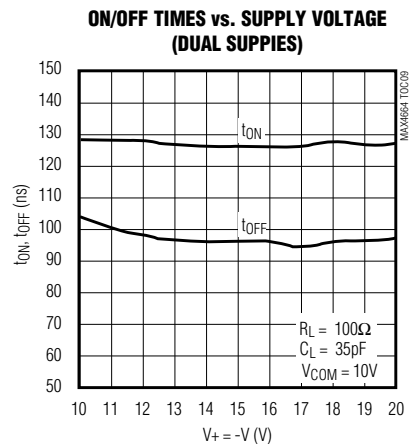
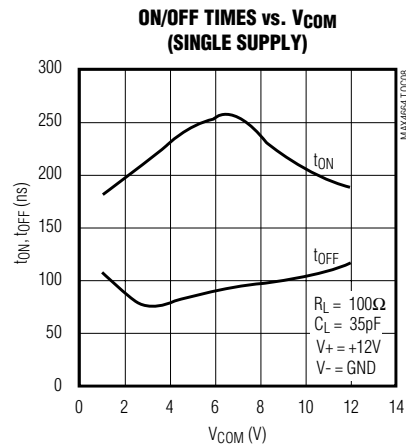
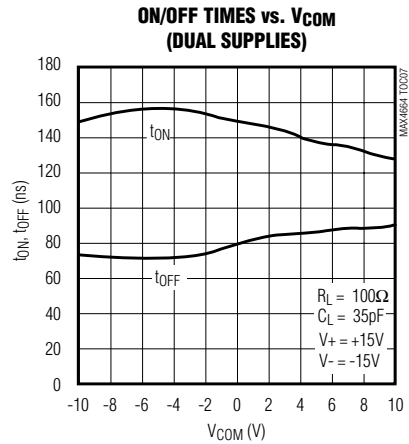
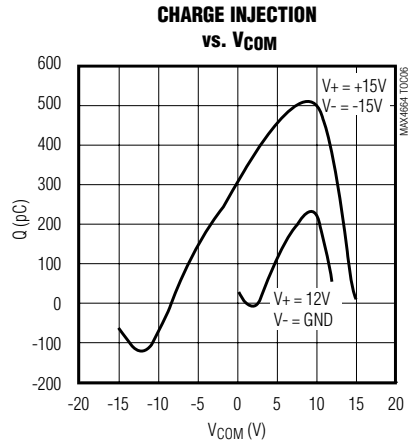
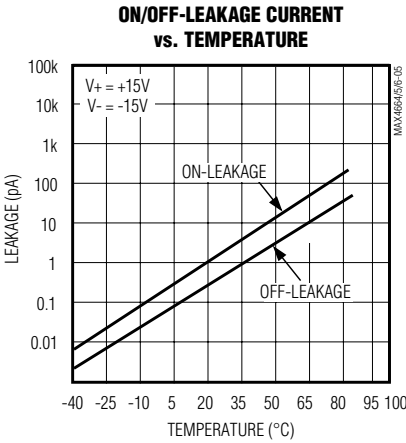
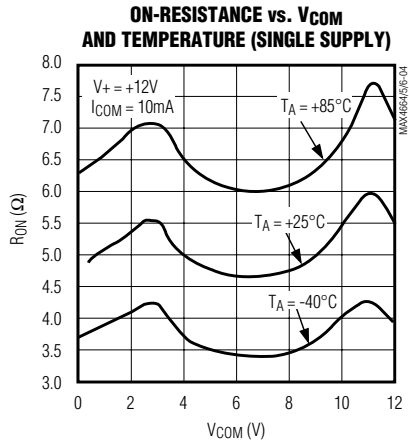
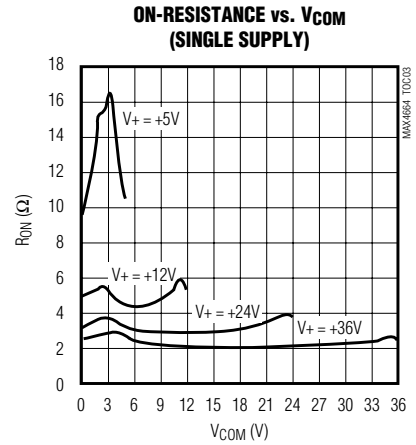
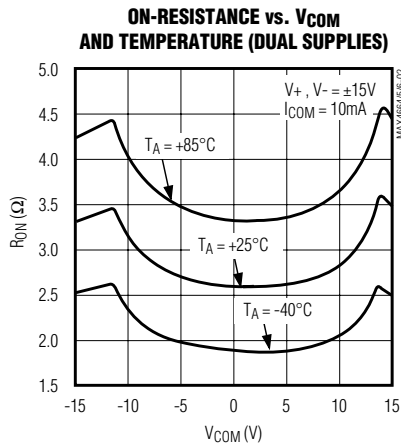
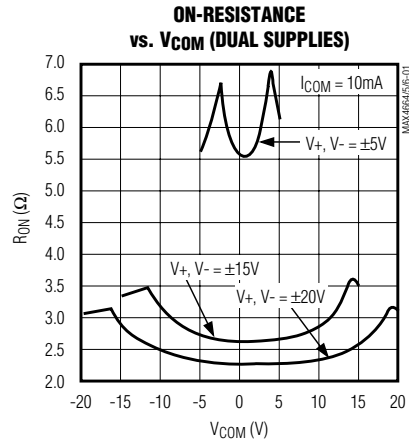

5Ω, Quad, SPST, CMOS Analog Switches

Typical Operating Characteristics (continued)

(TA = +25°C, unless otherwise noted.)

MAX4664/MAX4665/MAX4666

ON/OFF TIMES vs. SUPPLY VOLTAGE (SINGLE SUPPLY)

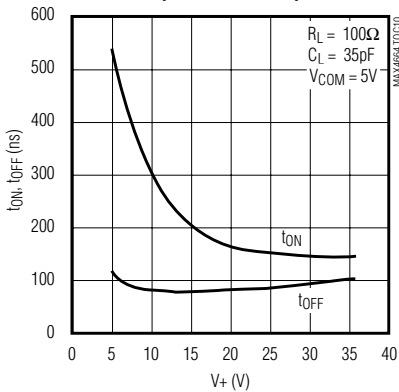

ON/OFF TIMES vs. TEMPERATURE (DUAL SUPPLIES)

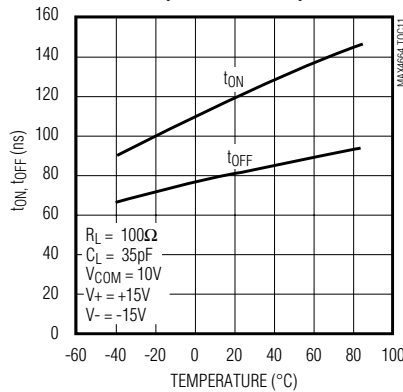

ON/OFF TIMES vs. TEMPERATURE (SINGLE SUPPLY)

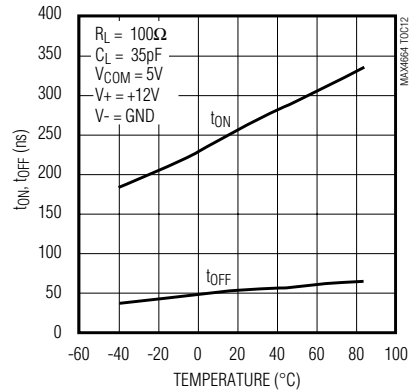

SUPPLY CURRENT vs. TEMPERATURE

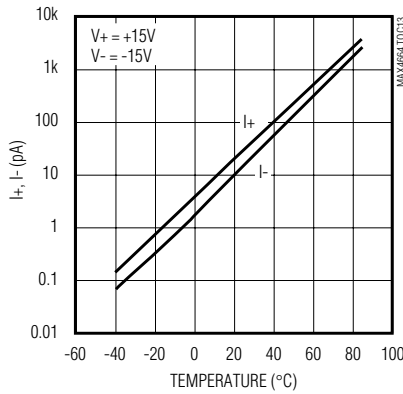

FREQUENCY RESPONSE

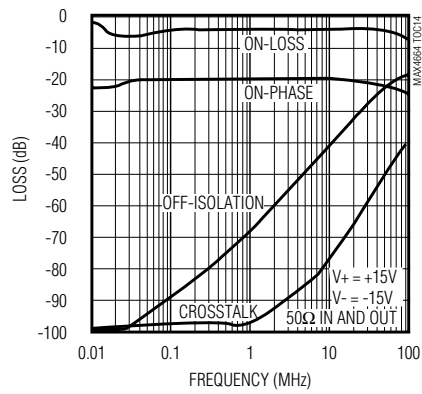

5Ω, Quad, SPST, CMOS Analog Switches

Pin Description

PIN			NAME	FUNCTION
MAX4664	MAX4665	MAX4666		
1, 16, 9, 8	1, 16, 9, 8	1, 16, 9, 8	IN1, IN2, IN3, IN4	Logic-Control Digital Inputs
2, 15, 10, 7	2, 15, 10, 7	2, 15, 10, 7	COM1, COM2, COM3, COM4	Analog Switch, Common Terminals
3,14, 11, 6	–	–	NC1, NC2, NC3, NC4	Analog Switch, Normally Closed Terminals
–	3,14, 11, 6	–	NO1, NO2, NO3, NO4	Analog Switch, Normally Open Terminals
–	–	3, 6	NO1, NO4	Analog Switch, Normally Open Terminal
–	–	14, 11	NC2, NC3	Analog Switch, Normally Closed Terminal
4	4	4	V-	Negative Analog Supply-Voltage Input. Connect to GND for single-supply operation.
5	5	5	GND	Ground
12	12	12	V _L	Logic-Supply Input
13	13	13	V+	Positive Analog Supply Input

Applications Information

Overvoltage Protection

Proper power-supply sequencing is recommended for all CMOS devices. Do not exceed the absolute maximum ratings, because stresses beyond the listed ratings can cause permanent damage to the devices. Always sequence V+ on first, then V-, followed by the logic inputs, NO, or COM. If power-supply sequencing is not possible, add two small signal diodes (D1, D2) in series with supply pins (Figure 1). Adding diodes reduces the analog signal range to one diode drop below V+ and one diode drop above V-, but does not affect the devices' low switch resistance and low leakage characteristics. Device operation is unchanged, and the difference between V+ and V- should not exceed 44V. These protection diodes are not recommended when using a single supply.

Off-Isolation at High Frequencies

In 50Ω systems, the high-frequency on-response of these parts extends from DC to above 100MHz, with a typical loss of -2dB. When the switch is turned off, however, it behaves like a capacitor, and off-isolation decreases with increasing frequency. (Above 300MHz,

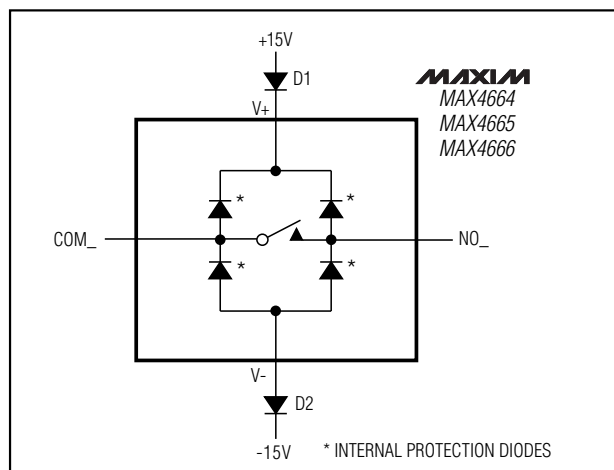

Figure 1. Overvoltage Protection Using External Blocking Diodes

the switch actually passes more signal turned off than turned on.) This effect is more pronounced with higher source and load impedances.

5Ω, Quad, SPST, CMOS Analog Switches

MAX4664/MAX4665/MAX4666

Above 5MHz, circuit board layout becomes critical, and it becomes difficult to characterize the response of the switch independent of the circuit. The graphs shown in the *Typical Operating Characteristics* were taken using a 50Ω source and load connected with BNC connectors to a circuit board deemed "average,"

that is, designed with isolation in mind, but not using stripline or other special RF circuit techniques. For critical applications above 5MHz, use the MAX440, MAX441, and MAX442, which are fully characterized up to 160MHz.

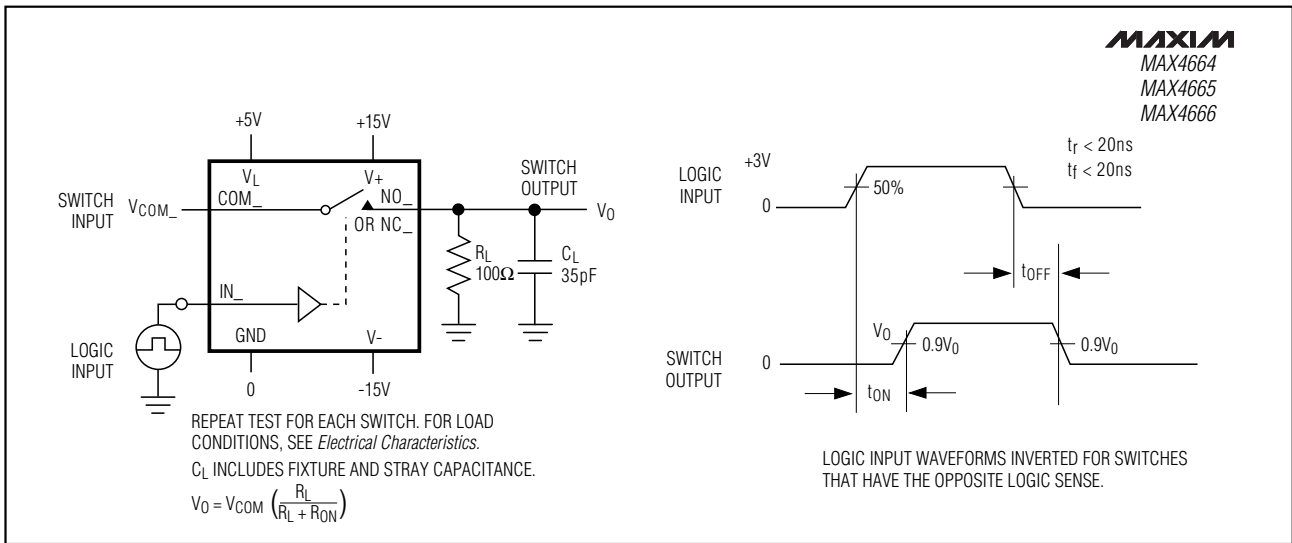

Figure 2. Switching-Time Test Circuit

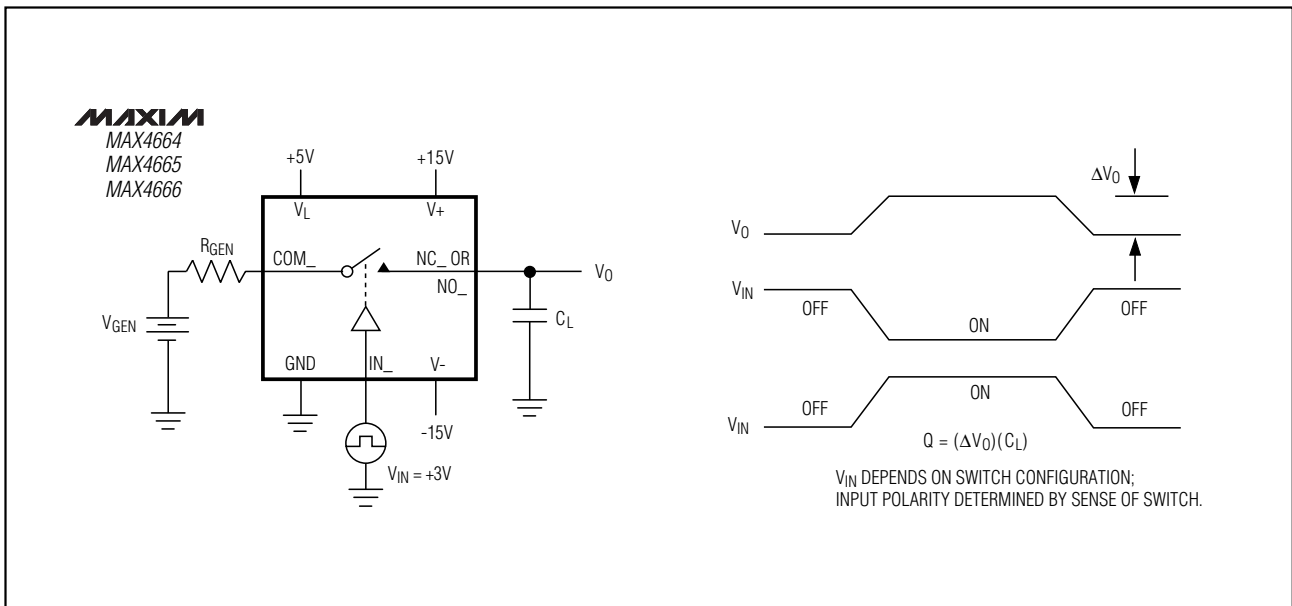

Figure 3. Charge-Injection Test Circuit

5Ω, Quad, SPST, CMOS Analog Switches

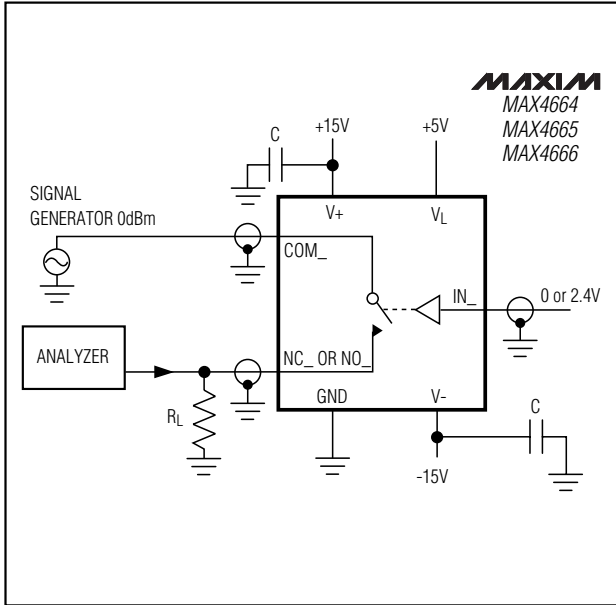

Figure 4. Off-Isolation Test Circuit

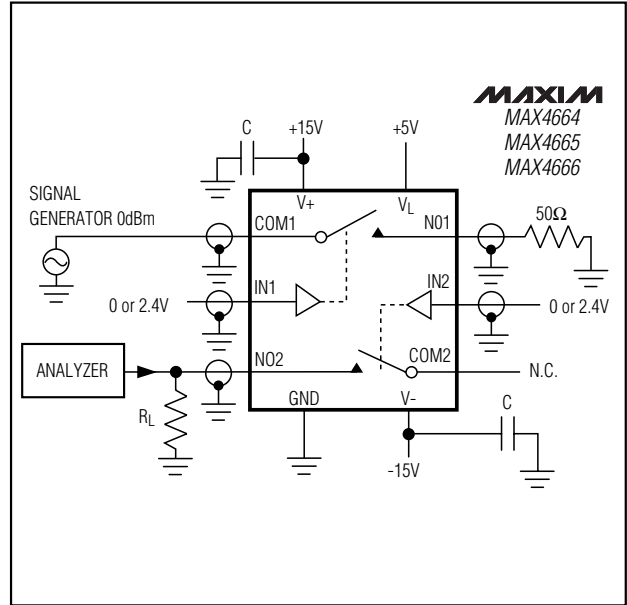

Figure 5. Crosstalk Test Circuit

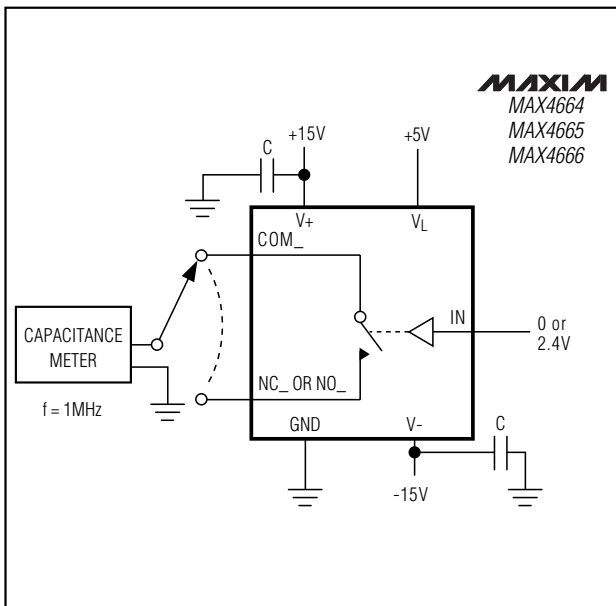

Figure 6. Switch Off-Capacitance Test Circuit

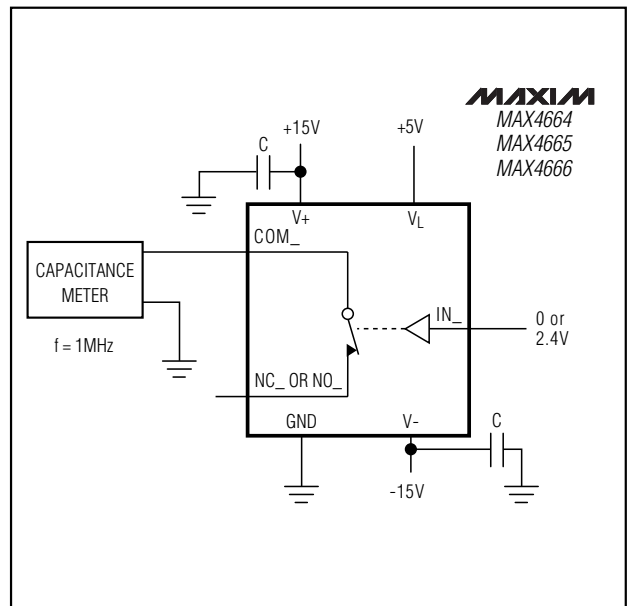

Figure 7. Switch On-Capacitance Test Circuit

5Ω, Quad, SPST, CMOS Analog Switches

Ordering Information (continued)

PART	TEMP. RANGE	PIN-PACKAGE
MAX4665CSE	0°C to +70°C	16 Narrow SO
MAX4665CPE	0°C to +70°C	16 Plastic DIP
MAX4665ESE	-40°C to +85°C	16 Narrow SO
MAX4665EPE	-40°C to +85°C	16 Plastic DIP
MAX4666CSE	0°C to +70°C	16 Narrow SO
MAX4666CPE	0°C to +70°C	16 Plastic DIP
MAX4666ESE	-40°C to +85°C	16 Narrow SO
MAX4666EPE	-40°C to +85°C	16 Plastic DIP

Chip Information

TRANSISTOR COUNT: 108

Package Information

	INCHES		MILLIMETERS	
	MIN	MAX	MIN	MAX
A	0.053	0.069	1.35	1.75
A1	0.004	0.010	0.10	0.25
B	0.014	0.019	0.35	0.49
C	0.007	0.010	0.19	0.25
e	0.050		1.27	
E	0.150	0.157	3.80	4.00
H	0.228	0.244	5.80	6.20
h	0.010	0.020	0.25	0.50
L	0.016	0.050	0.40	1.27

	INCHES		MILLIMETERS		N	MS012
	MIN	MAX	MIN	MAX		
D	0.189	0.197	4.80	5.00	8	A
D	0.337	0.344	8.55	8.75	14	B
D	0.386	0.394	9.80	10.00	16	C

NOTES:
 1. D&E DO NOT INCLUDE MOLD FLASH
 2. MOLD FLASH OR PROTRUSIONS NOT TO EXCEED .15mm (.006")
 3. LEADS TO BE COPLANAR WITHIN .102mm (.004")
 4. CONTROLLING DIMENSION: MILLIMETER
 5. MEETS JEDEC MS012-XX AS SHOWN IN ABOVE TABLE
 6. N = NUMBER OF PINS

MAXIM
 100 SAN CARLOS BLVD. SIMON VALLEY, CA 94585 TEL: (415) 737-7374
 PROPRIETARY INFORMATION

PACKAGE FAMILY OUTLINE: SOIC .150"

1/1

21-0041 A
 DOCUMENT CONTROL NUMBER REV

MAX4664/MAX4665/MAX4666

**5Ω, Quad, SPST,
CMOS Analog Switches**

Package Information (continued)

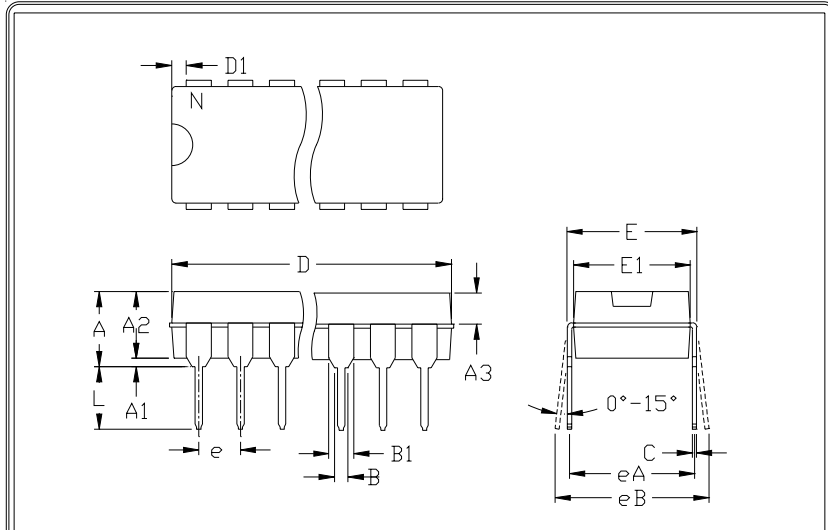

	INCHES		MILLIMETERS	
	MIN	MAX	MIN	MAX
A	---	0.200	---	5.08
A1	0.015	---	0.38	---
A2	0.125	0.175	3.18	4.45
A3	0.055	0.080	1.40	2.03
B	0.016	0.022	0.41	0.56
B1	0.045	0.065	1.14	1.65
C	0.008	0.012	0.20	0.30
D1	0.005	0.080	0.13	2.03
E	0.300	0.325	7.62	8.26
E1	0.240	0.310	6.10	7.87
e	0.100	---	2.54	---
eA	0.300	---	7.62	---
eB	---	0.400	---	10.16
L	0.115	0.150	2.92	3.81

	INCHES		MILLIMETERS		N	MS001
	MIN	MAX	MIN	MAX		
D	0.348	0.390	8.84	9.91	8	AB
D	0.735	0.765	18.67	19.43	14	AC
D	0.745	0.765	18.92	19.43	16	AA
D	0.885	0.915	22.48	23.24	18	AD
D	1.015	1.045	25.78	26.54	20	AE
D	1.14	1.265	28.96	32.13	24	AF
D	1.360	1.380	34.54	35.05	28	*5

- NOTES:
 1. D&E DO NOT INCLUDE MOLD FLASH
 2. MOLD FLASH OR PROTRUSIONS NOT TO EXCEED .15mm (.006")
 3. CONTROLLING DIMENSION: MILLIMETER
 4. MEETS JEDEC MS001-XX AS SHOWN IN ABOVE TABLE
 5. SIMILAR TO JEDEC MO-058AB
 6. N = NUMBER OF PINS



PACKAGE FAMILY OUTLINE: PDIP .300"

1/1

21-0043 A

Maxim cannot assume responsibility for use of any circuitry other than circuitry entirely embodied in a Maxim product. No circuit patent licenses are implied. Maxim reserves the right to change the circuitry and specifications without notice at any time.

12 Maxim Integrated Products, 120 San Gabriel Drive, Sunnyvale, CA 94086 408-737-7600