

Excellent Integrated System Limited

Stocking Distributor

Click to view price, real time Inventory, Delivery & Lifecycle Information:

[Texas Instruments](#)
[TPS22961DNYR](#)

For any questions, you can email us directly:

sales@integrated-circuit.com

TPS22961 3.5-V, 6-A, Ultra-low Resistance Load Switch

1 Features

- Integrated Single Channel Load Switch
- VBIAS Voltage Range: 3 V to 5.5 V
- Input Voltage Range: 0.8 V to 3.5 V
- Ultra low R_{ON} Resistance
 - $R_{ON} = 4.4 \text{ m}\Omega$ at $V_{IN} = 1.05 \text{ V}$ ($V_{BIAS} = 5 \text{ V}$)
- 6A Maximum Continuous Switch Current
- Low Quiescent Current $< 1 \mu\text{A}$ (max)
- Low Control Input Threshold Enables use of 1.2-V/1.8-V/2.5-V/3.3-V Logic
- Controlled Slew Rate
 - $t_R = 4.2 \mu\text{s}$ at $V_{IN} = 1.05 \text{ V}$ ($V_{BIAS} = 5 \text{ V}$)
- Quick Output Discharge (QOD)
- SON 8-terminal Package with Thermal Pad
- ESD Performance Tested per JESD 22
 - 2-kV HBM and 1-kV CDM

2 Applications

- Ultrabook™/Notebooks
- Desktops
- Servers
- Set-top Boxes
- Telecom Systems
- Tablet PC

3 Description

The TPS22961 is a small, ultra-low R_{ON} , single channel load switch with controlled turn on. The device contains an N-channel MOSFET that can operate over an input voltage range of 0.8 V to 3.5 V and supports a maximum continuous current of 6 A.

The combination of ultra-low R_{ON} and high current capability of the device makes it ideal for driving processor rails with very tight voltage dropout tolerances. Quick rise time of the device allows for power rails to come up quickly when the device is enabled, thereby reducing response time for power distribution. The switch can be independently controlled via the ON terminal, which is capable of interfacing directly with low-voltage control signals originating from microcontrollers or low voltage discrete logic. The device further reduces the total solution size by integrating a 260Ω pull-down transistor for quick output discharge (QOD) when the switch is turned off.

The TPS22961 is available in a small, space-saving 3 mm x 3 mm 8-SON package (DNY) with integrated thermal pad allowing for high power dissipation. The device is characterized for operation over the free-air temperature range of -40°C to 85°C .

Device Information⁽¹⁾

| PART NUMBER | PACKAGE | BODY SIZE |
|-------------|---------|-------------------|
| TPS22961 | WSN (8) | 3.00 mm x 3.00 mm |

(1) For all available packages, see the orderable addendum at the end of the datasheet.

4 Simplified Schematic

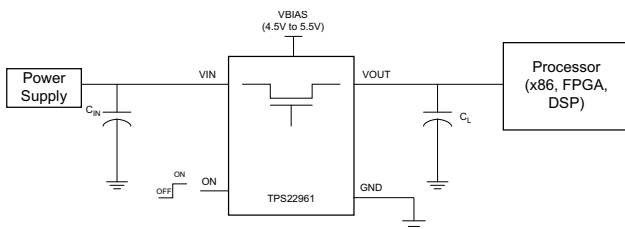

Typical Application: driving high current core rails for a processor

R_{ON} vs V_{IN} ($V_{BIAS} = 5 \text{ V}$, $I_{OUT} = -200 \text{ mA}$)

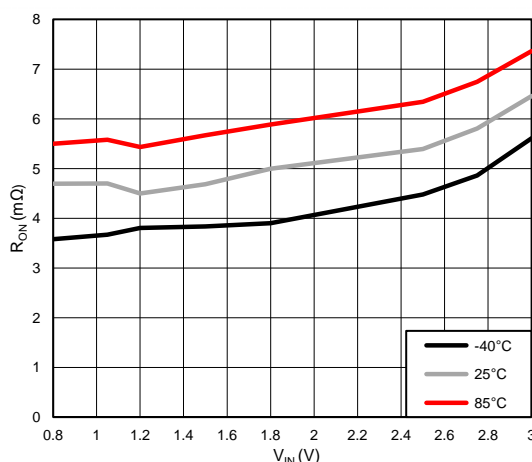

TPS22961

SLVSCI4B – FEBRUARY 2014 – REVISED SEPTEMBER 2014

www.ti.com

Table of Contents

| | | | |
|---|-----------|--|-----------|
| 1 Features | 1 | 8.1 Overview | 12 |
| 2 Applications | 1 | 8.2 Functional Block Diagram | 12 |
| 3 Description | 1 | 8.3 Feature Description | 13 |
| 4 Simplified Schematic | 1 | 9 Applications and Implementation | 14 |
| 5 Revision History | 2 | 9.1 Application Information | 14 |
| 6 Terminal Configuration and Functions | 3 | 9.2 Typical Application | 14 |
| 7 Specifications | 3 | 10 Power Supply Recommendations | 18 |
| 7.1 Absolute Maximum Ratings | 3 | 11 Layout | 19 |
| 7.2 Handling Ratings | 4 | 11.1 Layout Guidelines | 19 |
| 7.3 Recommended Operating Conditions | 4 | 11.2 Layout Example | 19 |
| 7.4 Thermal Information | 4 | 12 Device and Documentation Support | 20 |
| 7.5 Electrical Characteristics, $V_{BIAS} = 5.0\text{ V}$ | 5 | 12.1 Trademarks | 20 |
| 7.6 Electrical Characteristics, $V_{BIAS} = 3.0\text{ V}$ | 5 | 12.2 Electrostatic Discharge Caution | 20 |
| 7.7 Switching Characteristics | 6 | 12.3 Glossary | 20 |
| 7.8 Typical Characteristics | 8 | 13 Mechanical, Packaging, and Orderable Information | 20 |
| 8 Detailed Description | 12 | | |

5 Revision History

| Changes from Revision A (February 2014) to Revision B | Page |
|---|------|
| • Fixed caption error in Filtered Output curve. | 18 |

| Changes from Original (February 2014) to Revision A | Page |
|---|------|
| • Initial release of full version. | 1 |

6 Terminal Configuration and Functions

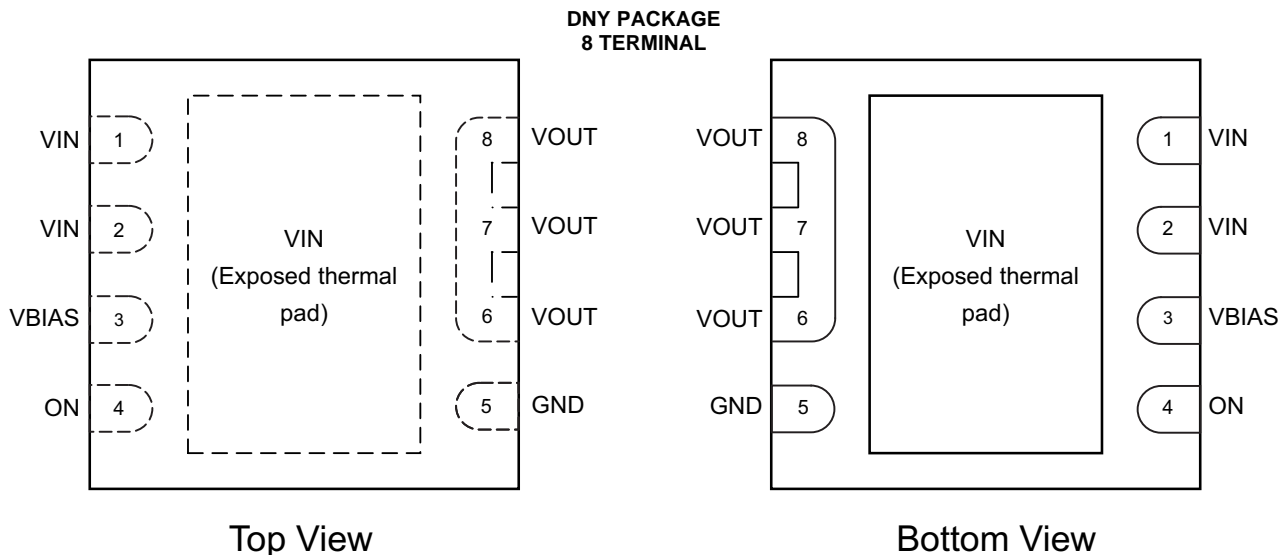

Pin Functions

| PIN | | I/O | DESCRIPTION |
|-------|---------------------|-----|--|
| NAME | NO. | | |
| VIN | 1, 2 | I | Switch input. Place ceramic bypass capacitor(s) between this terminal and GND. See Detailed Description section for more information. |
| VIN | Exposed thermal Pad | I | Switch input. Place ceramic bypass capacitor(s) between this terminal and GND. See Detailed Description section for more information. |
| VBIAS | 3 | I | Bias voltage. Power supply to the device. |
| ON | 4 | I | Active high switch control input. Do not leave floating. |
| GND | 5 | – | Ground. |
| VOUT | 6, 7, 8 | O | Switch output. Place ceramic bypass capacitor(s) between this terminal and GND. See Detailed Description section for more information. |

7 Specifications

7.1 Absolute Maximum Ratings

Over operating free-air temperature range (unless otherwise noted)⁽¹⁾

| | | MIN | MAX | UNIT |
|-------------------|--|------|-----|------|
| V _{IN} | Input voltage range | –0.3 | 4 | V |
| V _{BIAS} | Bias voltage range | –0.3 | 6 | V |
| V _{OUT} | Output voltage range | –0.3 | 4 | V |
| V _{ON} | ON pin voltage range | –0.3 | 6 | V |
| I _{MAX} | Maximum Continuous Switch Current | | 6 | A |
| I _{PLS} | Maximum Pulsed Switch Current, pulse < 300 μs, 2% duty cycle | | 8 | A |
| T _A | Operating free-air temperature range | –40 | 85 | °C |
| T _J | Maximum junction temperature | | 125 | °C |

(1) Stresses beyond those listed under [Absolute Maximum Ratings](#) may cause permanent damage to the device. These are stress ratings only, which do not imply functional operation of the device at these or any other conditions beyond those indicated under [Recommended Operating Conditions](#). Exposure to absolute-maximum-rated conditions for extended periods may affect device reliability.

TPS22961

SLVSCI4B – FEBRUARY 2014 – REVISED SEPTEMBER 2014

www.ti.com
7.2 Handling Ratings

| | | MIN | MAX | UNIT |
|---------------------------------|--|-----|-----|------|
| T _{STG} | Storage temperature range | -65 | 150 | °C |
| T _{LEAD} | Maximum lead temperature (10-s soldering time) | | 300 | °C |
| V _{ESD} ⁽¹⁾ | Human-Body Model (HBM) ⁽²⁾ | | 2 | kV |
| | Charged-Device Model (CDM) ⁽³⁾ | | 1 | kV |

- (1) Electrostatic discharge (ESD) to measure device sensitivity and immunity to damage caused by assembly line electrostatic discharges in to the device.
- (2) Level listed above is the passing level per ANSI, ESDA, and JEDEC JS-001. JEDEC document JEP155 states that 500-V HBM allows safe manufacturing with a standard ESD control process.
- (3) Level listed above is the passing level per EIA-JEDEC JESD22-C101. JEDEC document JEP157 states that 250-V CDM allows safe manufacturing with a standard ESD control process.

7.3 Recommended Operating Conditions

Over operating free-air temperature range (unless otherwise noted)

| | | MIN | MAX | UNIT | | |
|---------------------|------------------------|----------------------------------|--------------------------|------------------|-----|----|
| V _{IN} | Input voltage range | 0.8 | V _{BIAS} – 1.95 | V | | |
| V _{BIAS} | Bias voltage range | 3 | 5.5 | V | | |
| V _{ON} | ON voltage range | 0 | 5.5 | V | | |
| V _{OUT} | Output voltage range | | V _{IN} | V | | |
| V _{IH, ON} | High-level voltage, ON | V _{BIAS} = 3 V to 5.5 V | | 1.2 | 5.5 | V |
| V _{IL, ON} | Low-level voltage, ON | V _{BIAS} = 3 V to 5.5 V | | 0 | 0.5 | V |
| C _{IN} | Input Capacitor | | | 1 ⁽¹⁾ | | μF |

- (1) Refer to [Detailed Description](#) section.

7.4 Thermal Information

| THERMAL METRIC ⁽¹⁾ | | TPS22961 | | UNIT |
|-------------------------------|--|----------|--|------|
| | | DNY | | |
| | | 8 PINS | | |
| θ _{JA} | Junction-to-ambient thermal resistance | 44.6 | | °C/W |
| θ _{JCtop} | Junction-to-case (top) thermal resistance | 44.4 | | |
| θ _{JB} | Junction-to-board thermal resistance | 17.6 | | |
| ψ _{JT} | Junction-to-top characterization parameter | 0.4 | | |
| ψ _{JB} | Junction-to-board characterization parameter | 17.4 | | |
| θ _{JCbot} | Junction-to-case (bottom) thermal resistance | 1.1 | | |

- (1) For more information about traditional and new thermal metrics, see the *IC Package Thermal Metrics* application report, [SPRA953](#).

7.5 Electrical Characteristics, $V_{BIAS} = 5.0\text{ V}$

Unless otherwise noted, the specification in the following table applies over the operating ambient temperature $-40^{\circ}\text{C} \leq T_A \leq 85^{\circ}\text{C}$ (full) and $V_{BIAS} = 5.0\text{ V}$. Typical values are for $T_A = 25^{\circ}\text{C}$ (unless otherwise noted).

| PARAMETER | | TEST CONDITIONS | T_A | MIN | TYP | MAX | UNIT | |
|------------------------------------|-----------------------------------|--|--------------------------|------|--------------------------|--------|---------------|---------------|
| POWER SUPPLIES AND CURRENTS | | | | | | | | |
| I_Q, V_{BIAS} | V_{BIAS} quiescent current | $I_{OUT} = 0, V_{IN} = 3\text{ V}, V_{ON} = V_{BIAS} = 5.0\text{ V}$ | Full | | 0.6 | 1 | μA | |
| I_{SD}, V_{BIAS} | V_{BIAS} shutdown current | $V_{ON} = 0\text{ V}, V_{OUT} = 0\text{ V}$ | Full | | 0.6 | 1 | μA | |
| I_{SD}, V_{IN} | V_{IN} shutdown current | $V_{ON} = 0\text{ V}, V_{OUT} = 0\text{ V}$ | Full | | $V_{IN} = 3.0\text{ V}$ | 0.0009 | 0.1 | μA |
| | | | | | $V_{IN} = 2.5\text{ V}$ | 0.0008 | 0.1 | |
| | | | | | $V_{IN} = 2.0\text{ V}$ | 0.0007 | 0.1 | |
| | | | | | $V_{IN} = 1.05\text{ V}$ | 0.0007 | 0.1 | |
| | | | | | $V_{IN} = 0.8\text{ V}$ | 0.0006 | 0.1 | |
| I_{ON} | ON terminal input leakage current | $V_{ON} = 5.5\text{ V}$ | Full | | | 0.1 | μA | |
| RESISTANCE CHARACTERISTICS | | | | | | | | |
| R_{ON} | ON-state resistance | $I_{OUT} = -200\text{ mA}, V_{BIAS} = 5.0\text{ V}$ | $V_{IN} = 3.0\text{ V}$ | 25°C | 6.5 | 8 | m Ω | |
| | | | | Full | | 8.8 | | |
| | | | $V_{IN} = 2.5\text{ V}$ | 25°C | 5.3 | 6.3 | m Ω | |
| | | | | Full | | 7.2 | | |
| | | | $V_{IN} = 2.0\text{ V}$ | 25°C | 4.8 | 5.8 | m Ω | |
| | | | | Full | | 6.7 | | |
| | | | $V_{IN} = 1.05\text{ V}$ | 25°C | 4.4 | 5.3 | m Ω | |
| | | | | Full | | 6.2 | | |
| | | | $V_{IN} = 0.8\text{ V}$ | 25°C | 4.3 | 5.3 | m Ω | |
| | | | | Full | | 6.1 | | |
| R_{PD} | Output pulldown resistance | $V_{IN} = 5.0\text{ V}, V_{ON} = 0\text{ V}, V_{OUT} = 1\text{ V}$ | Full | | 260 | 300 | Ω | |

7.6 Electrical Characteristics, $V_{BIAS} = 3.0\text{ V}$

Unless otherwise noted, the specification in the following table applies over the operating ambient temperature $-40^{\circ}\text{C} \leq T_A \leq 85^{\circ}\text{C}$ (full) and $V_{BIAS} = 3.0\text{ V}$. Typical values are for $T_A = 25^{\circ}\text{C}$ unless otherwise noted.

| PARAMETER | | TEST CONDITIONS | T_A | MIN | TYP | MAX | UNIT | |
|------------------------------------|-----------------------------------|--|--------------------------|------|--------------------------|--------|---------------|---------------|
| POWER SUPPLIES AND CURRENTS | | | | | | | | |
| I_Q, V_{BIAS} | V_{BIAS} quiescent current | $I_{OUT} = 0, V_{IN} = 1\text{ V}, V_{ON} = V_{BIAS} = 3.0\text{ V}$ | Full | | 0.3 | 1 | μA | |
| I_{SD}, V_{BIAS} | V_{BIAS} shutdown current | $V_{ON} = 0\text{ V}, V_{OUT} = 0\text{ V}$ | Full | | 0.3 | 1 | μA | |
| I_{SD}, V_{IN} | V_{IN} shutdown current | $V_{ON} = 0\text{ V}, V_{OUT} = 0\text{ V}$ | Full | | $V_{IN} = 1.05\text{ V}$ | 0.001 | 0.1 | μA |
| | | | | | $V_{IN} = 0.8\text{ V}$ | 0.0008 | 0.1 | |
| I_{ON} | ON terminal input leakage current | $V_{ON} = 5.5\text{ V}$ | Full | | | 0.1 | μA | |
| RESISTANCE CHARACTERISTICS | | | | | | | | |
| R_{ON} | ON-state resistance | $I_{OUT} = -200\text{ mA}, V_{BIAS} = 3.0\text{ V}$ | $V_{IN} = 1.05\text{ V}$ | 25°C | 6.7 | 8.4 | m Ω | |
| | | | | Full | | 9.2 | | |
| | | | $V_{IN} = 0.8\text{ V}$ | 25°C | 5.8 | 7.0 | m Ω | |
| | | | | Full | | 7.9 | | |
| R_{PD} | Output pull-down resistance | $V_{IN} = 3\text{ V}, V_{ON} = 0\text{ V}, V_{OUT} = 1\text{ V}$ | Full | | 260 | 300 | Ω | |

TPS22961

SLVSCI4B – FEBRUARY 2014 – REVISED SEPTEMBER 2014

www.ti.com
7.7 Switching Characteristics

 Refer to the timing test circuit in [Figure 1](#) (unless otherwise noted) for references to external components used for the test condition in the switching characteristics table.

| PARAMETER | TEST CONDITION | MIN | TYP | MAX | UNIT | |
|--|---|-----|-------|------|---------------|------|
| $V_{IN} = 2.5\text{ V}$, $V_{ON} = V_{BIAS} = 5\text{ V}$, $T_A = 25^\circ\text{C}$ (unless otherwise noted) | | | | | | |
| t_{ON} Turn-on time | $R_L = 10\ \Omega$, $C_L = 0.1\ \mu\text{F}$ | | 10.0 | | μs | |
| t_{OFF} Turn-off time | | | 3.5 | | | |
| t_R V_{OUT} rise time | | | 6.3 | | | |
| t_F V_{OUT} fall time | | | 2.0 | | | |
| t_D Delay time | | | 8.1 | | | |
| $V_{IN} = 1.05\text{ V}$, $V_{ON} = V_{BIAS} = 5\text{ V}$, $T_A = 25^\circ\text{C}$ (unless otherwise noted) | | | | | | |
| t_{ON} Turn-on time | $L = 2.2\ \mu\text{H}$ (DCR = $0.33\ \Omega$), $C = 2 \times 22\ \mu\text{F}$ (Refer to <i>Typical Application Powering Rails Sensitive to Ringing and Overvoltage due to Fast Rise Time</i> and Figure 31) | 8.1 | 11.3 | 17.3 | μs | |
| t_{OFF} Turn-off time | | | 13700 | | | |
| t_R V_{OUT} rise time | | | 5 | 9.5 | | 12.5 |
| t_F V_{OUT} fall time | | | 44200 | | | |
| t_D Delay time | | | 6.7 | 9.3 | | 12.5 |
| $V_{IN} = 0.8\text{ V}$, $V_{ON} = V_{BIAS} = 5\text{ V}$, $T_A = 25^\circ\text{C}$ (unless otherwise noted) | | | | | | |
| t_{ON} Turn-on time | $R_L = 10\ \Omega$, $C_L = 0.1\ \mu\text{F}$ | | 9.7 | | μs | |
| t_{OFF} Turn-off time | | | 6.0 | | | |
| t_R V_{OUT} rise time | | | 3.2 | | | |
| t_F V_{OUT} fall time | | | 1.8 | | | |
| t_D Delay time | | | 8.1 | | | |
| $V_{IN} = 1.05\text{ V}$, $V_{ON} = 5\text{ V}$, $V_{BIAS} = 3.0\text{ V}$, $T_A = 25^\circ\text{C}$ (unless otherwise noted) | | | | | | |
| t_{ON} Turn-on time | $R_L = 10\ \Omega$, $C_L = 0.1\ \mu\text{F}$ | | 19.1 | | μs | |
| t_{OFF} Turn-off time | | | 4.7 | | | |
| t_R V_{OUT} rise time | | | 9.0 | | | |
| t_F V_{OUT} fall time | | | 2.0 | | | |
| t_D Delay time | | | 15.6 | | | |
| $V_{IN} = 0.8\text{ V}$, $V_{ON} = 5\text{ V}$, $V_{BIAS} = 3.0\text{ V}$, $T_A = 25^\circ\text{C}$ (unless otherwise noted) | | | | | | |
| t_{ON} Turn-on time | $R_L = 10\ \Omega$, $C_L = 0.1\ \mu\text{F}$ | | 19.0 | | μs | |
| t_{OFF} Turn-off time | | | 5.4 | | | |
| t_R V_{OUT} rise time | | | 7.0 | | | |
| t_F V_{OUT} fall time | | | 1.9 | | | |
| t_D Delay time | | | 15.7 | | | |

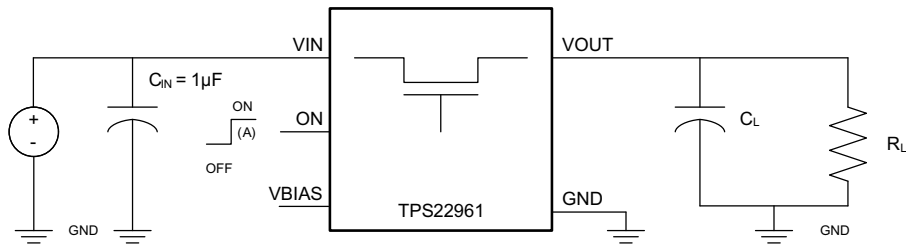

Timing Test Circuit

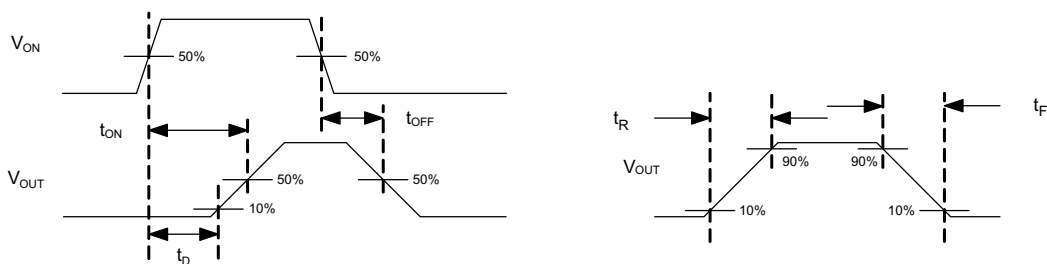

Timing Waveforms

(A) Rise and fall times of the control signal is 100ns.

Figure 1. Switching Characteristics Measurement Setup and Definitions

TPS22961

SLVSCI4B – FEBRUARY 2014 – REVISED SEPTEMBER 2014

www.ti.com

7.8 Typical Characteristics

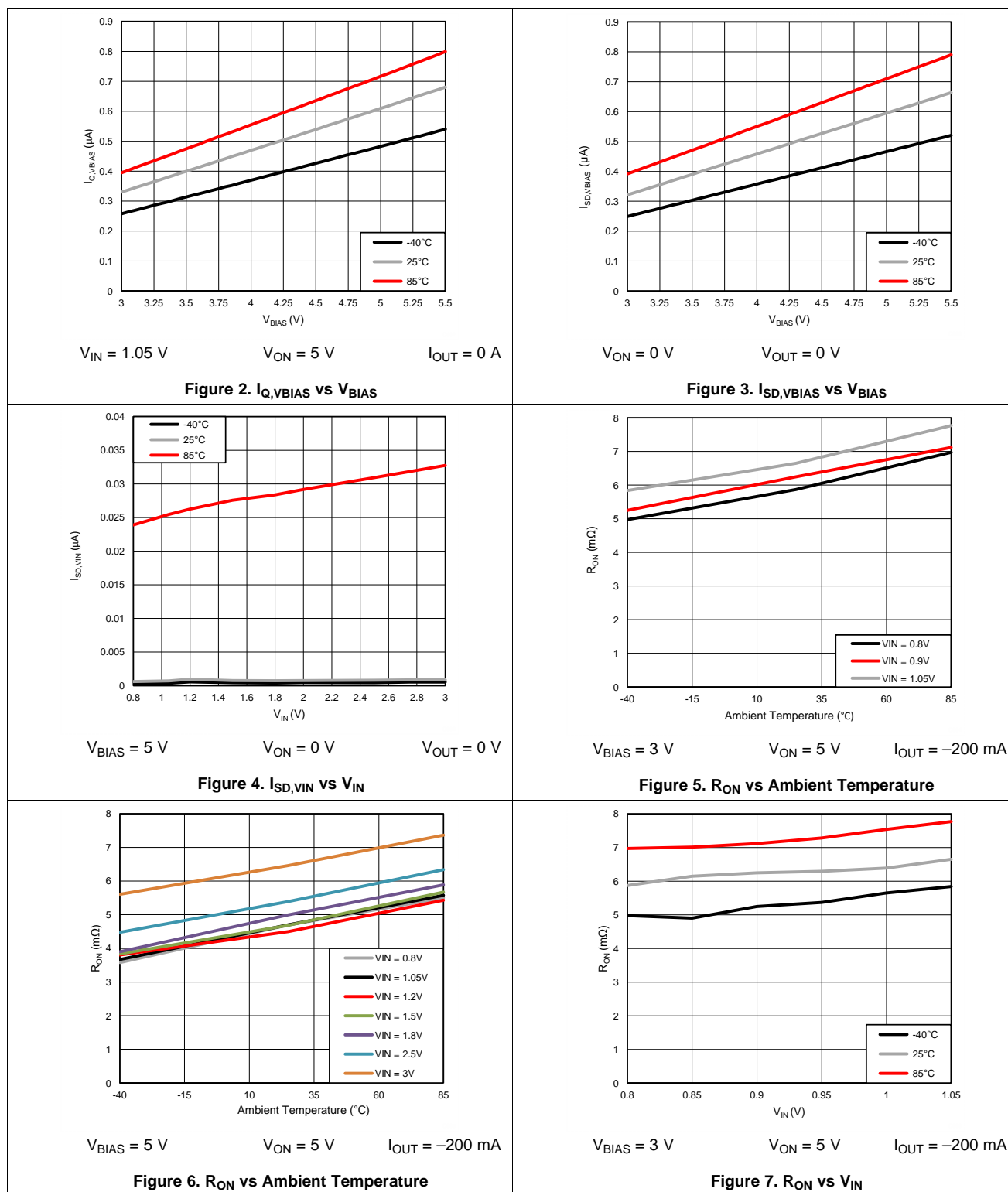

Typical Characteristics (continued)

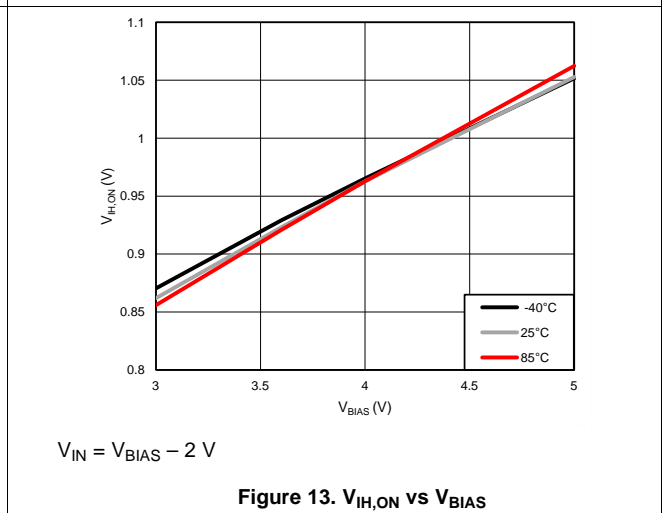
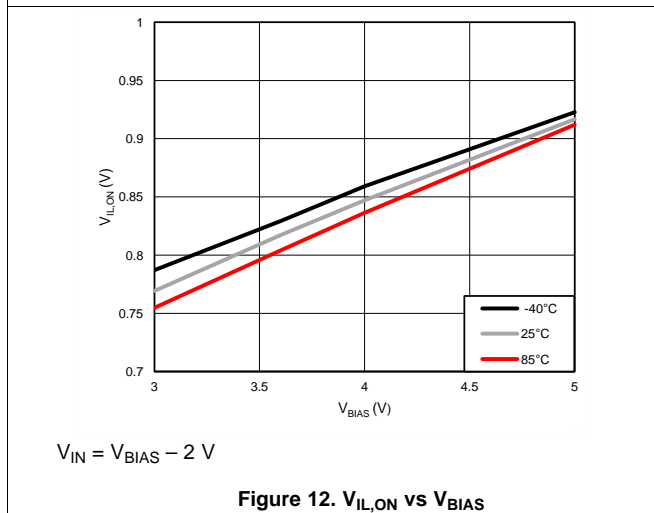
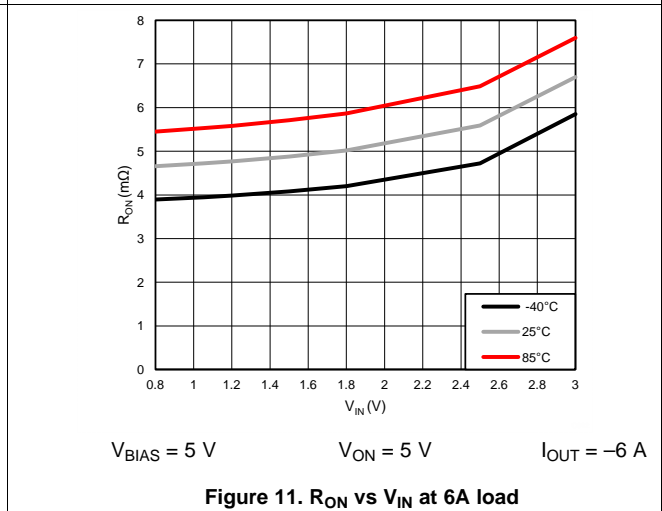
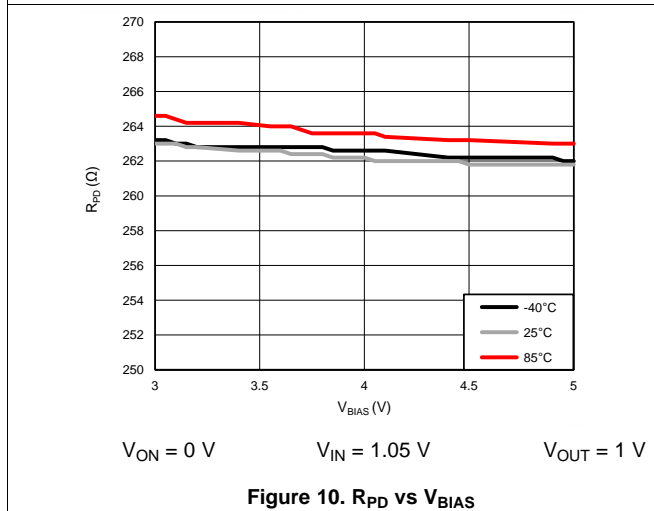
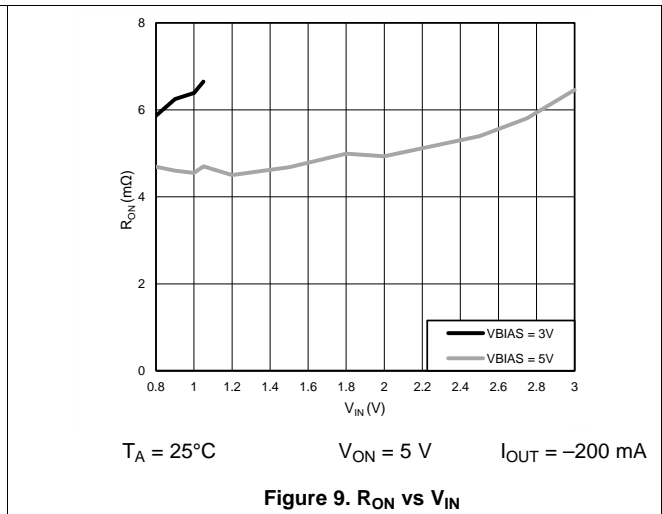
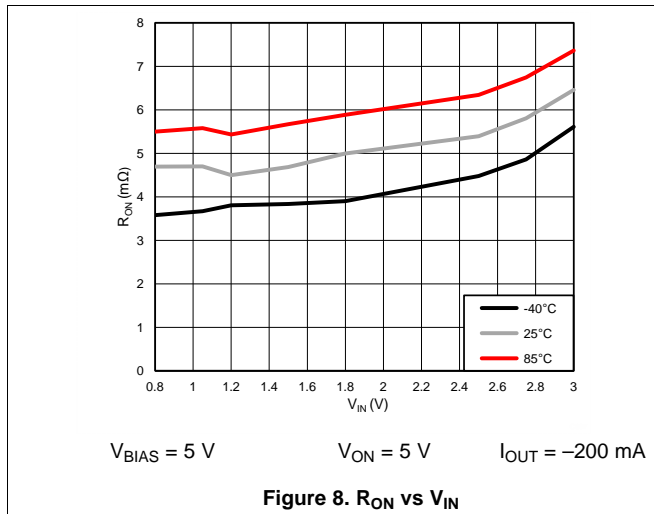

TPS22961

SLVSCI4B – FEBRUARY 2014 – REVISED SEPTEMBER 2014

www.ti.com

Typical Characteristics (continued)

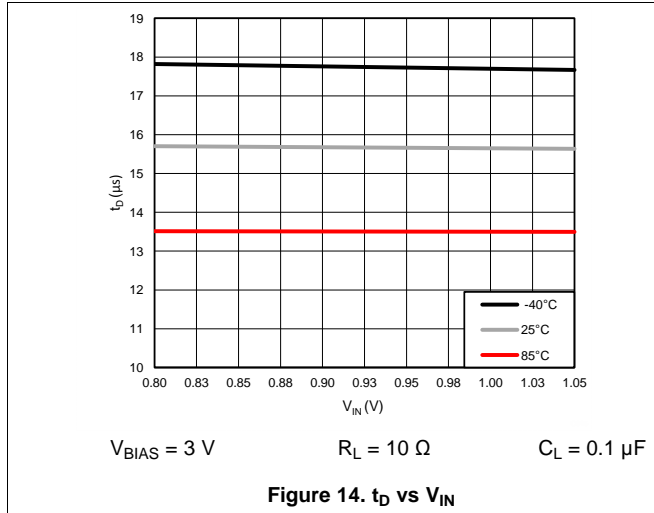

Figure 14. t_D vs V_{IN}

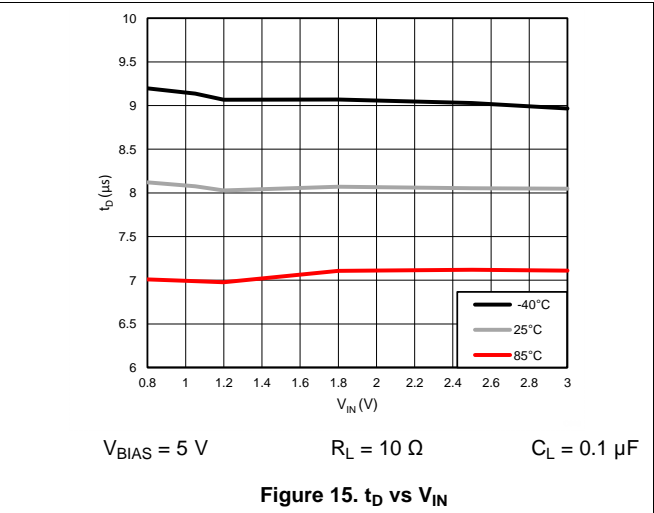

Figure 15. t_D vs V_{IN}

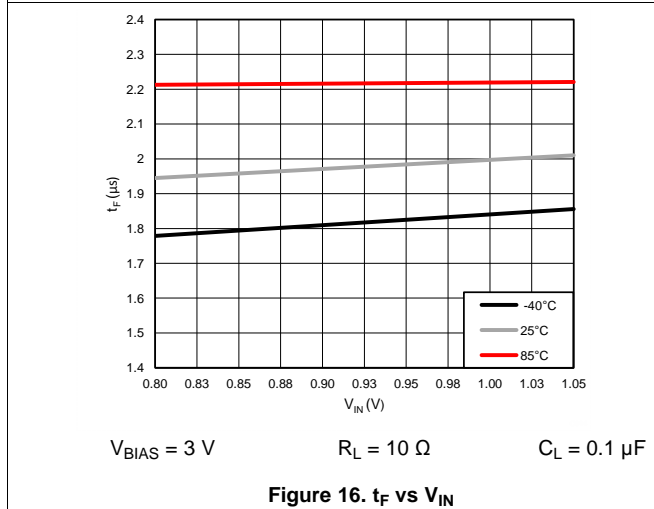

Figure 16. t_F vs V_{IN}

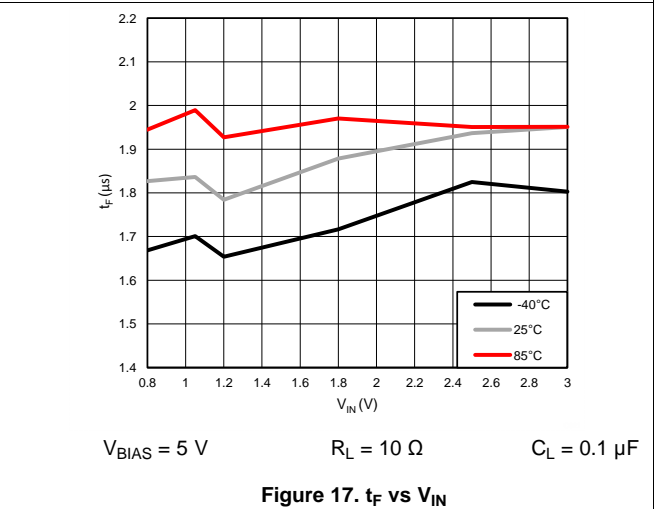

Figure 17. t_F vs V_{IN}

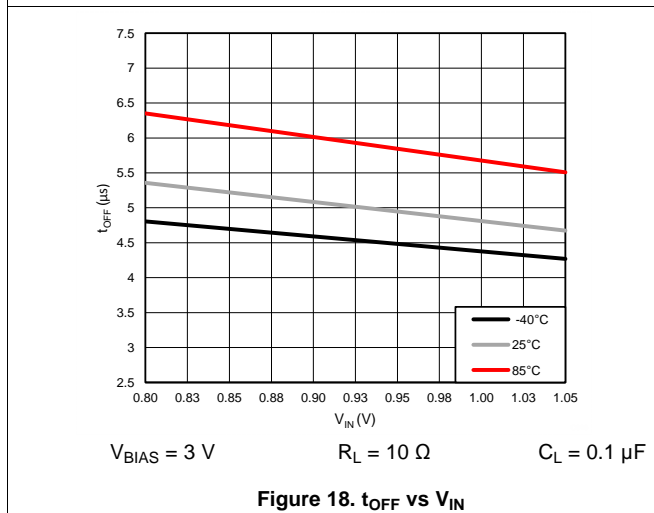

Figure 18. t_{OFF} vs V_{IN}

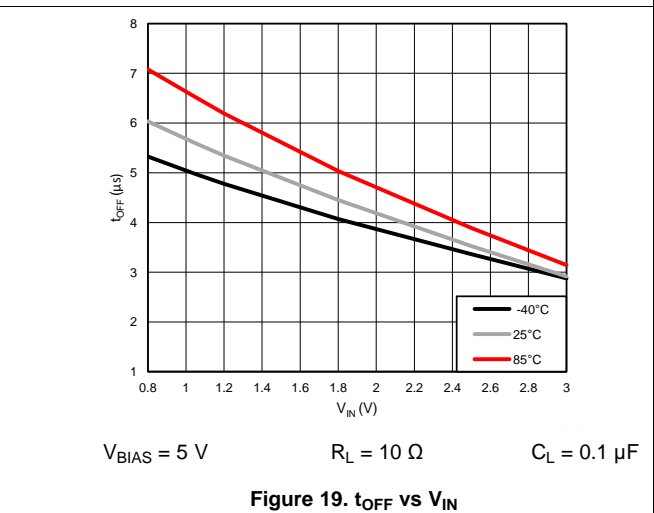
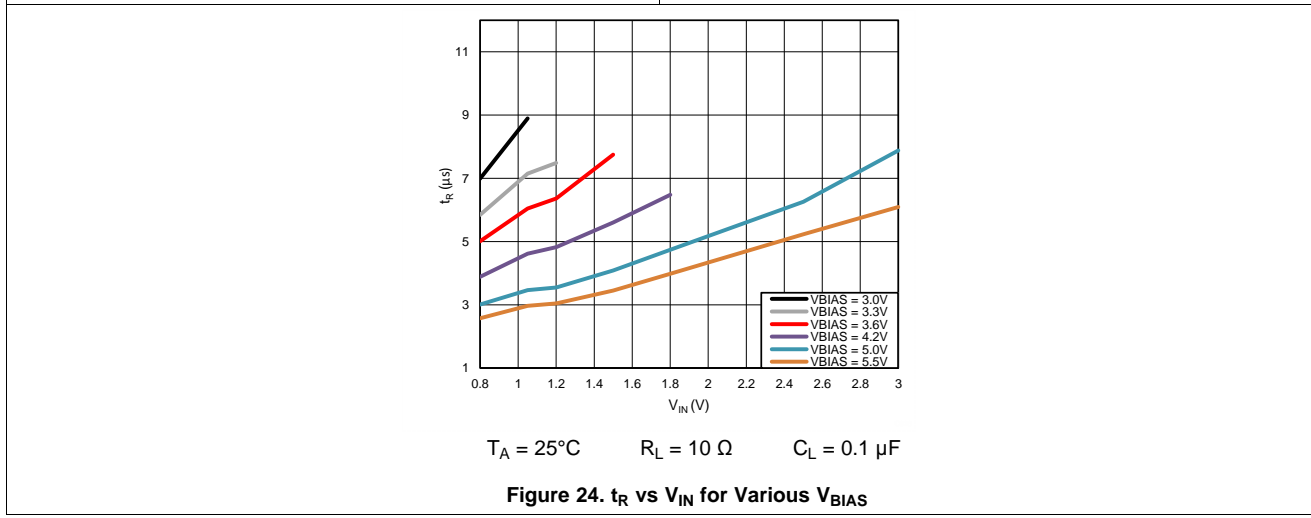
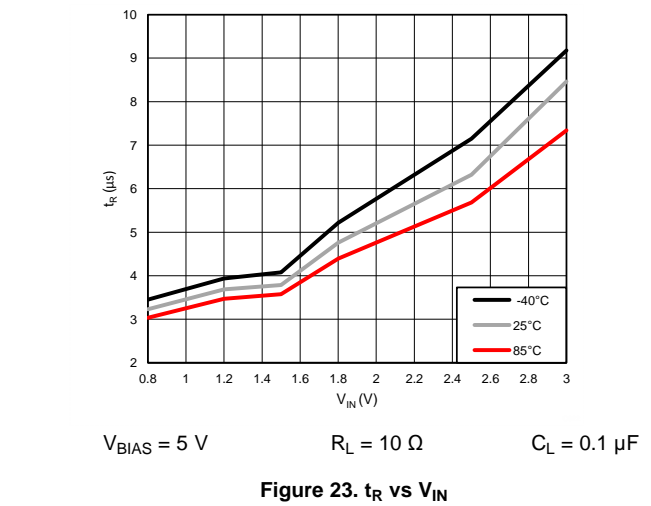
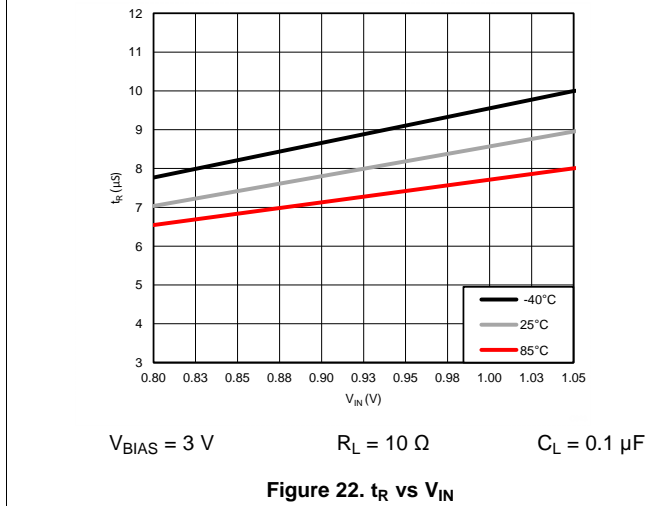
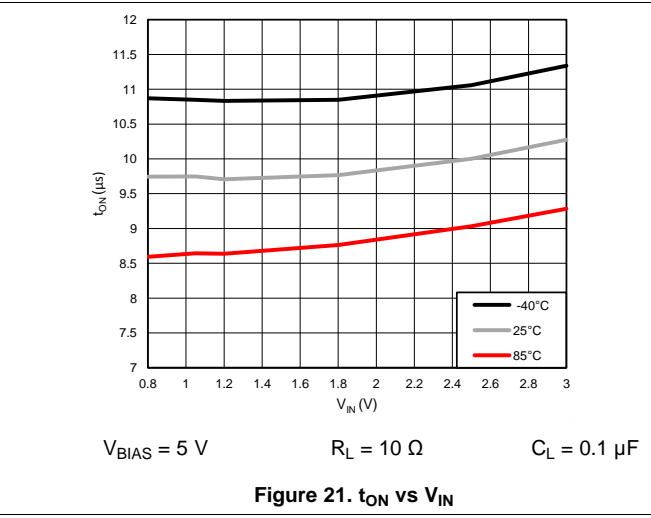
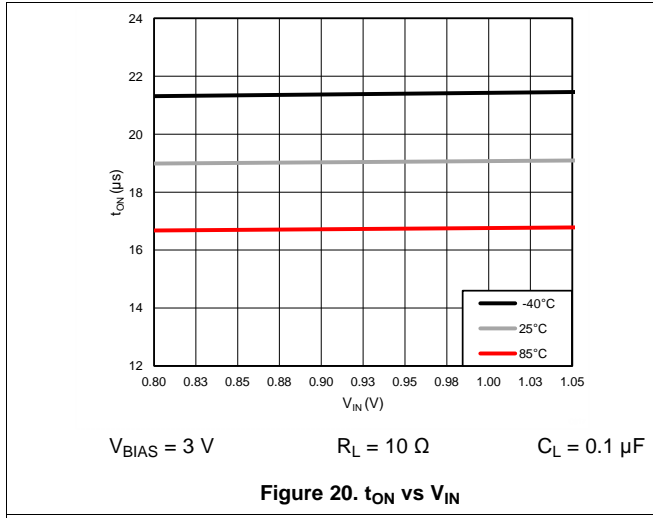

Figure 19. t_{OFF} vs V_{IN}

Typical Characteristics (continued)



TPS22961

SLVSCI4B – FEBRUARY 2014 – REVISED SEPTEMBER 2014

www.ti.com

8 Detailed Description

8.1 Overview

The device is a 3.5 V, 6 A load switch in a 8-terminal SON package. To reduce voltage drop for low voltage and high current rails, the device implements an ultra-low resistance N-channel MOSFET which reduces the drop out voltage through the device at very high currents.

The device has a controlled, yet quick, fixed slew rate for applications that require quick turn-on response. During shutdown, the device has very low leakage currents, thereby reducing unnecessary leakages for downstream modules during standby. Integrated control logic, driver, and output discharge FET eliminates the need for any external components, which reduces solution size and BOM count.

8.2 Functional Block Diagram

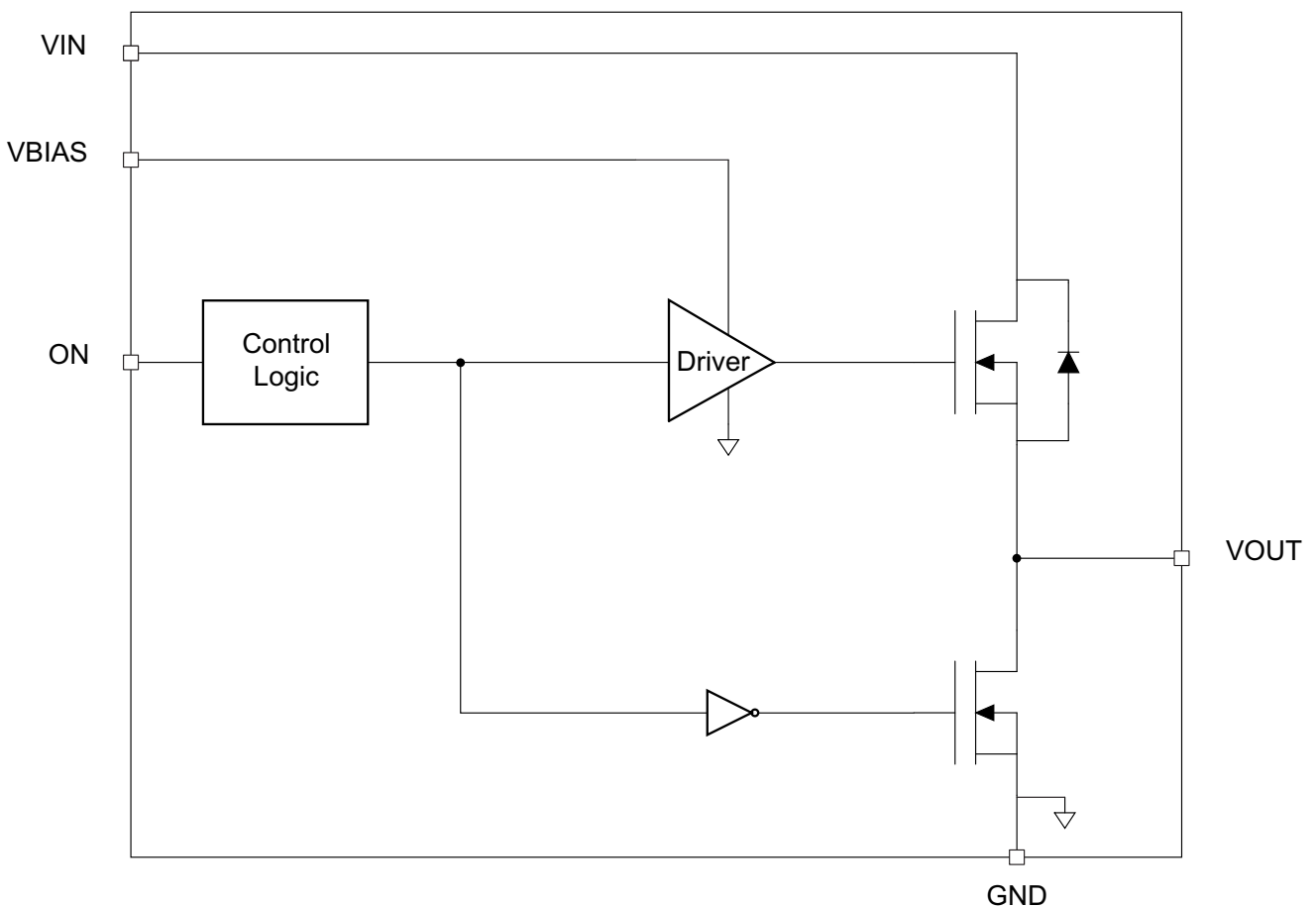

8.3 Feature Description

8.3.1 On/off Control

The ON terminal controls the state of the load switch, and asserting the terminal high (active high) enables the switch. The ON terminal is compatible with standard GPIO logic threshold and can be used with any microcontroller or discrete logic with 1.2 V or higher GPIO voltage. This terminal cannot be left floating and must be tied either high or low for proper functionality.

8.3.2 Input Capacitor (C_{IN})

To limit the voltage drop on the input supply caused by transient in-rush currents when the switch turns on into a discharged load capacitor or short-circuit, a capacitor needs to be placed between V_{IN} and GND. A 1 μ F ceramic capacitor, C_{IN} , placed close to the terminals, is usually sufficient. Higher values of C_{IN} can be used to further reduce the voltage drop in high-current application. When switching heavy loads, it is recommended to have an input capacitor 10 times higher than the output capacitor to avoid excessive voltage drop.

8.3.3 Output Capacitor (C_L)

Due to the integrated body diode in the NMOS switch, a C_{IN} greater than C_L is highly recommended. A C_L greater than C_{IN} can cause V_{OUT} to exceed V_{IN} when the system supply is removed. This could result in current flow through the body diode from V_{OUT} to V_{IN} . A C_{IN} to C_L ratio of 10 to 1 is recommended for minimizing V_{IN} dip caused by inrush currents during startup, however a 10 to 1 ratio for capacitance is not required for proper functionality of the device. A ratio smaller than 10 to 1 (such as 1 to 1) could cause a V_{IN} dip upon turn-on due to inrush currents.

8.3.4 V_{IN} and V_{BIAS} Voltage Range

For optimal R_{ON} performance, make sure $V_{IN} \leq (V_{BIAS} - 1.95 \text{ V})$. For example, in order to have $V_{IN} = 3.5\text{V}$, V_{BIAS} must be 5.5 V. The device will still be functional if $V_{IN} > (V_{BIAS} - 1.95 \text{ V})$ but it will exhibit R_{ON} greater than what is listed in the [Electrical Characteristics, \$V_{BIAS} = 5.0 \text{ V}\$](#) table. See [Figure 25](#) for an example of a typical device. Notice the increasing R_{ON} as V_{IN} increases. Be sure to never exceed the maximum voltage rating for V_{IN} and V_{BIAS} .

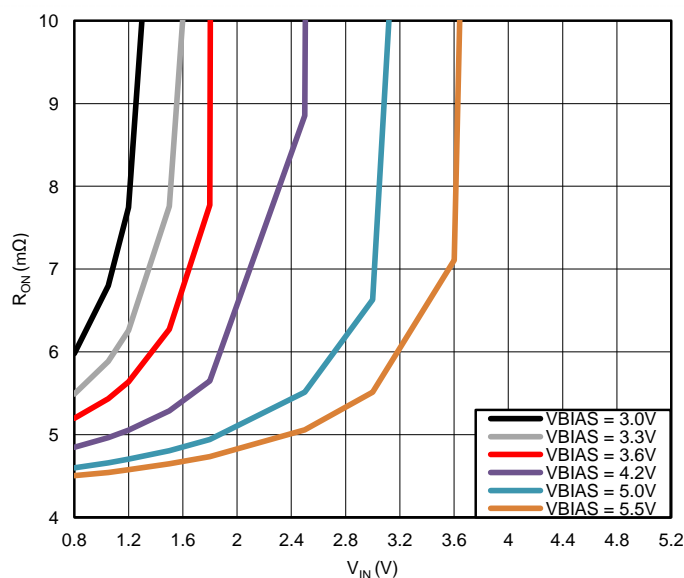

Figure 25. R_{ON} vs V_{IN} ($V_{IN} > V_{BIAS}$)

TPS22961

SLVSCI4B – FEBRUARY 2014 – REVISED SEPTEMBER 2014

www.ti.com

9 Applications and Implementation

NOTE

Information in the following applications sections is not part of the TI component specification, and TI does not warrant its accuracy or completeness. TI's customers are responsible for determining suitability of components for their purposes. Customers should validate and test their design implementation to confirm system functionality.

9.1 Application Information

This section will highlight some of the design considerations when implementing this device in various applications. A PSPICE model for this device is also available in the product page of this device on www.ti.com for further aid.

9.2 Typical Application

9.2.1 Typical Application Powering a Downstream Module

This application demonstrates how the TPS22961 can be used to power downstream modules.

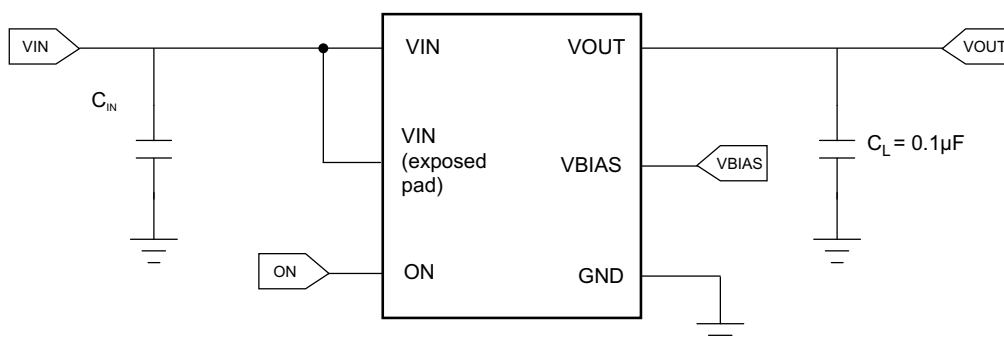

Figure 26. Typical Application Schematic for Powering a Downstream Module

9.2.1.1 Design Requirements

For this design example, use the following as the input parameters.

Table 1. Design Parameters

| DESIGN PARAMETER | EXAMPLE VALUE |
|------------------|---------------|
| V_{IN} | 1.05 V |
| V_{BIAS} | 5.0 V |
| Load current | 6 A |

9.2.1.2 Detailed Design Procedure

To begin the design process, the designer needs to know the following:

- VIN voltage
- VBIAS voltage
- Load current

9.2.1.2.1 VIN to VOUT Voltage Drop

The VIN to VOUT voltage drop in the device is determined by the R_{ON} of the device and the load current. The R_{ON} of the device depends upon the V_{IN} and V_{BIAS} conditions of the device. Refer to the R_{ON} specification of the device in the Electrical Characteristics table of this datasheet. Once the R_{ON} of the device is determined based upon the V_{IN} and V_{BIAS} conditions, use [Equation 1](#) to calculate the VIN to VOUT voltage drop:

$$\Delta V = I_{LOAD} \times R_{ON} \quad (1)$$

where

- ΔV = voltage drop from VIN to VOUT
- I_{LOAD} = load current
- R_{ON} = On-resistance of the device for a specific V_{IN} and V_{BIAS} combination

An appropriate I_{LOAD} must be chosen such that the I_{MAX} specification of the device is not violated.

9.2.1.2.2 Inrush Current

To determine how much inrush current will be caused by the C_L capacitor, use [Equation 2](#):

$$I_{INRUSH} = C_L \times \frac{dV_{OUT}}{dt} \quad (2)$$

where

- I_{INRUSH} = amount of inrush caused by C_L
- C_L = capacitance on VOUT
- dt = time it takes for change in V_{OUT} during the ramp up of VOUT when the device is enabled
- dV_{OUT} = change in V_{OUT} during the ramp up of VOUT when the device is enabled

An appropriate C_L value should be placed on VOUT such that the I_{MAX} and I_{PLS} specifications of the device are not violated.

9.2.1.2.3 Thermal Considerations

The maximum IC junction temperature should be restricted to 125°C under normal operating conditions. To calculate the maximum allowable dissipation, $P_{D(max)}$ for a given output current and ambient temperature, use [Equation 3](#).

$$P_{D(MAX)} = \frac{T_{J(MAX)} - T_A}{R_{\theta JA}} \quad (3)$$

where

- $P_{D(max)}$ = maximum allowable power dissipation
- $T_{J(max)}$ = maximum allowable junction temperature (125°C for the TPS22961)
- T_A = ambient temperature of the device
- Θ_{JA} = junction to air thermal impedance. See [Thermal Information](#) section. This parameter is highly dependent upon board layout.

TPS22961

SLVSCI4B – FEBRUARY 2014 – REVISED SEPTEMBER 2014

www.ti.com

9.2.1.3 Application Curves

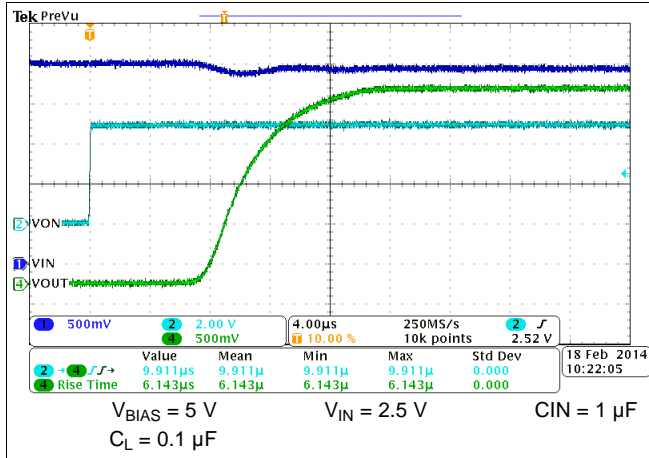

Figure 27. t_R at $V_{BIAS} = 5\text{ V}$

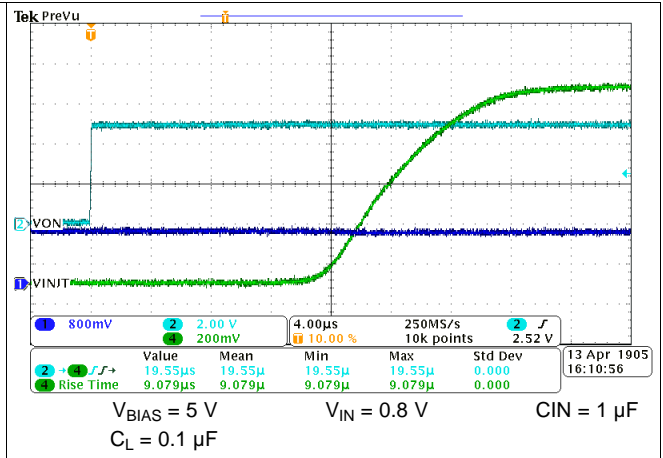

Figure 28. t_R at $V_{BIAS} = 5\text{ V}$

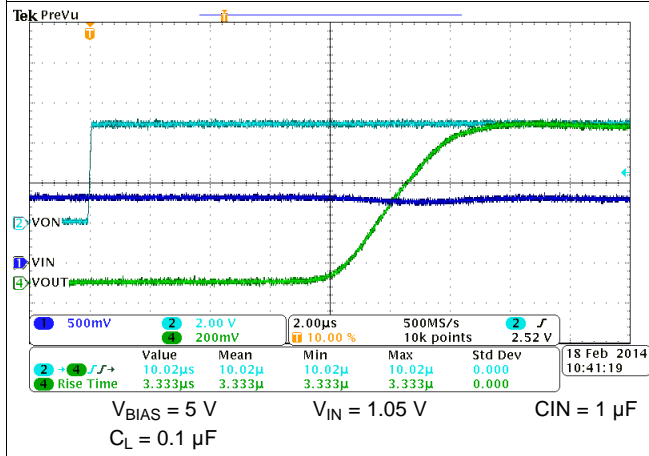

Figure 29. t_R at $V_{BIAS} = 3\text{ V}$

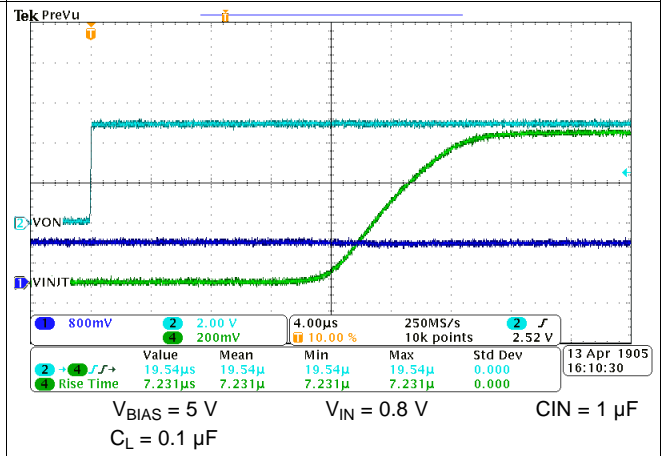

Figure 30. t_R at $V_{BIAS} = 3\text{ V}$

9.2.2 Typical Application Powering Rails Sensitive to Ringing and Overvoltage due to Fast Rise Time

This application demonstrates how the TPS22961 can be used to power rails sensitive to ringing and overvoltage that can often happen due to fast rise times.

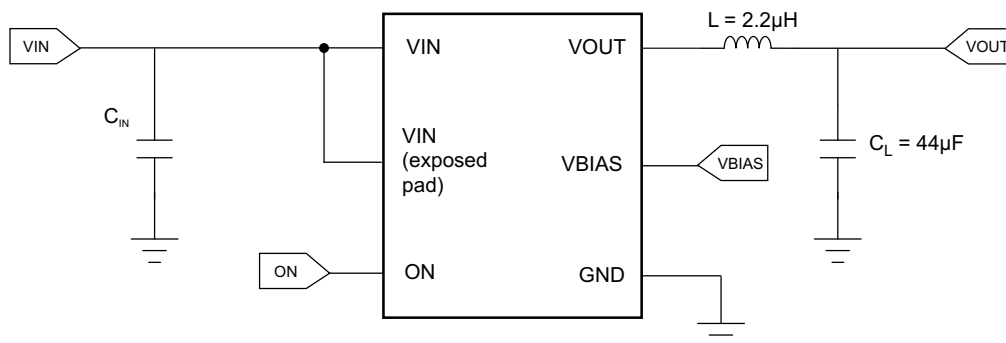

Figure 31. Typical Application Schematic for Powering Rails Sensitive to Ringing

9.2.2.1 Design Requirements

For this design example, use the following as the input parameters.

Table 2. Design Parameters

| DESIGN PARAMETER | EXAMPLE VALUE |
|---|---------------|
| V_{IN} | 1.05 V |
| V_{BIAS} | 5.0 V |
| Acceptable percent overshoot (ρ) | 3.2% |
| Maximum settling time (t_{SETTLE}) | 40 μ s |

9.2.2.2 Detailed Design Procedure

To begin the design process, the designer needs to know the following:

- V_{IN} voltage
- V_{BIAS} voltage
- Acceptable percent overshoot
- Maximum allowed settling time for the power rail

9.2.2.2.1 Picking Proper Inductor and Capacitor to Meet Voltage Overshoot Requirements

To determine the value of L and C_L in the circuit, the damping factor associated with the acceptable percent overshoot must be calculated. To calculate the damping factor (ϵ), use Equation 4.

$$\epsilon = \frac{-\ln \rho}{\sqrt{\pi^2 + (\ln \rho)^2}} \quad (4)$$

where

- ϵ = damping factor of the LC filter
- ρ = allowable percent overshoot for the power rail

TPS22961

SLVSCI4B – FEBRUARY 2014 – REVISED SEPTEMBER 2014

www.ti.com

Use the damping factor calculated in Equation 4 to determine the inductance (L), the DCR of the inductor (R_{DCR}), and capacitance (C_L) to achieve the percent overshoot. This will be an iterative process to determine the optimal combination of L and C_L with standard value components available. Use Equation 5 to determine the combination of L, R_{DCR}, and C_L that is needed to satisfy damping factor calculated from Equation 4.

$$\epsilon = \frac{R_{DCR}}{2} \times \sqrt{\frac{C_L}{L}} \tag{5}$$

where

- ϵ = damping factor of the LC filter
- R_{DCR} = DCR of the inductor
- C_L = the capacitance of the filter
- L = the inductor of the filter

To determine the setting time (within 5% of steady state value) of the filter, use Equation 6.

$$t_{SETTLE} \approx \frac{3 \times \sqrt{L \times C_L}}{\epsilon} \tag{6}$$

where

- t_{SETTLE} = settling time of filter to within 5% of steady state value
- ϵ = damping factor of the LC filter
- C_L = the capacitance of the filter
- L = the inductor of the filter

The combination of damping factor (ϵ) and filter settling time (t_{SETTLE}) will bound the values for L, R_{DCR}, and C_L that can be used to meet the design constraints in Table 2.

9.2.2.3 Application Curves

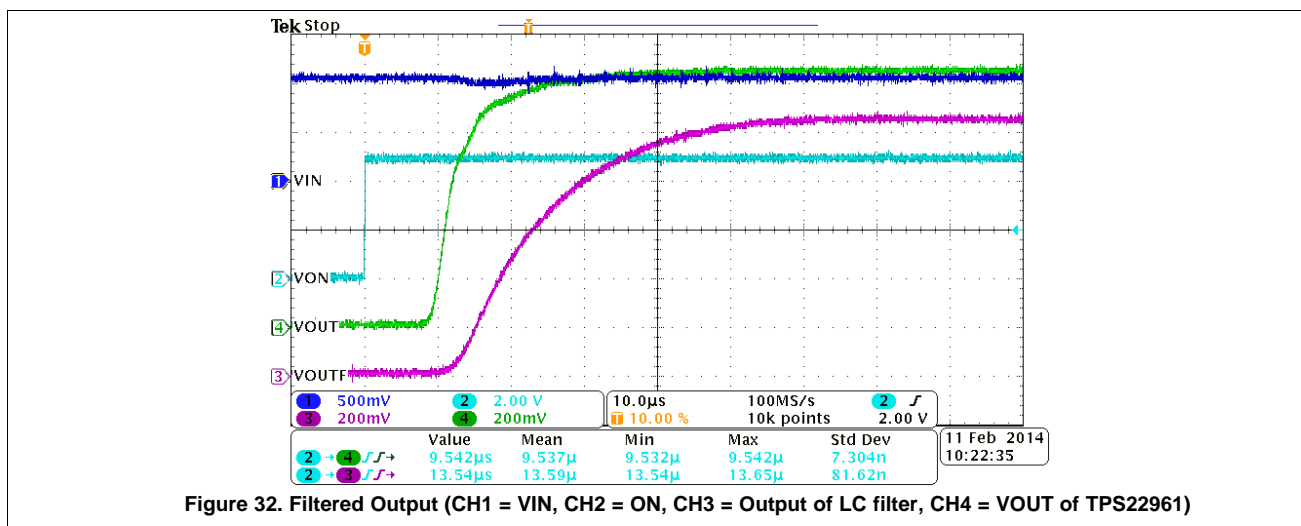

10 Power Supply Recommendations

The device is designed to operate from a V_{BIAS} range of 3 V to 5.5 V and VIN range of 0.8 V to 3.5 V. This supply must be well regulated and placed as close to the TPS22961 as possible. If the supply is located more than a few inches from the device terminals, additional bulk capacitance may be required in addition to the ceramic bypass capacitors. An electrolytic, tantalum, or ceramic capacitor of 10 µF may be sufficient.

11 Layout

11.1 Layout Guidelines

- VIN and VOUT traces should be as short and wide as possible to accommodate for high current.
- Use vias under the exposed thermal pad for thermal relief for high current operation.
- The VIN terminal should be bypassed to ground with low ESR ceramic bypass capacitors. The typical recommended bypass capacitance is 1- μ F ceramic with X5R or X7R dielectric. This capacitor should be placed as close to the device terminals as possible.
- The VOUT terminal should be bypassed to ground with low ESR ceramic bypass capacitors. The typical recommended bypass capacitance is one-tenth of the VIN bypass capacitor of X5R or X7R dielectric rating. This capacitor should be placed as close to the device terminals as possible.
- The VBIAS terminal should be bypassed to ground with low ESR ceramic bypass capacitors. The typical recommended bypass capacitance is 0.1- μ F ceramic with X5R or X7R dielectric.

11.2 Layout Example

○ VIA to Power Ground Plane

⌋ VIA to VIN Plane

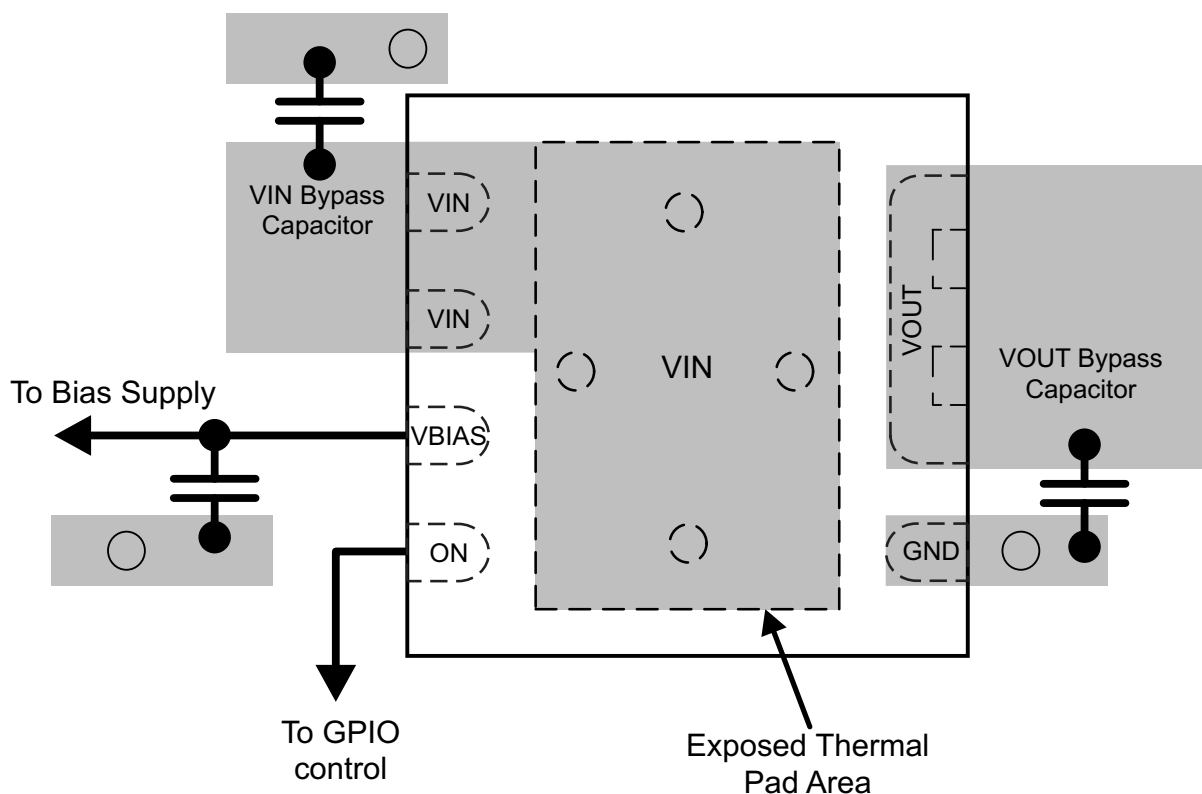

Figure 33. Recommended Board Layout

TPS22961

SLVSCI4B – FEBRUARY 2014 – REVISED SEPTEMBER 2014

www.ti.com

12 Device and Documentation Support

12.1 Trademarks

Ultrabook is a trademark of Intel.

12.2 Electrostatic Discharge Caution



These devices have limited built-in ESD protection. The leads should be shorted together or the device placed in conductive foam during storage or handling to prevent electrostatic damage to the MOS gates.

12.3 Glossary

[SLYZ022](#) — *TI Glossary*.

This glossary lists and explains terms, acronyms, and definitions.

13 Mechanical, Packaging, and Orderable Information

The following pages include mechanical packaging and orderable information. This information is the most current data available for the designated devices. This data is subject to change without notice and revision of this document. For browser-based versions of this data sheet, refer to the left-hand navigation.



PACKAGING INFORMATION

| Orderable Device | Status (1) | Package Type | Package Drawing | Pins | Package Qty | Eco Plan (2) | Lead/Ball Finish (6) | MSL Peak Temp (3) | Op Temp (°C) | Device Marking (4/5) | Samples |
|------------------|---------------|--------------|-----------------|------|-------------|-------------------------|-------------------------|----------------------|--------------|-------------------------|---------|
| TPS22961DNYR | ACTIVE | WSON | DNY | 8 | 3000 | Green (RoHS & no Sb/Br) | CU NIPDAU | Level-2-260C-1 YEAR | -40 to 85 | 961A1 | |
| TPS22961DNYT | ACTIVE | WSON | DNY | 8 | 250 | Green (RoHS & no Sb/Br) | CU NIPDAU | Level-2-260C-1 YEAR | -40 to 85 | 961A1 | |

(1) The marketing status values are defined as follows:

ACTIVE: Product device recommended for new designs.

LIFEBUY: TI has announced that the device will be discontinued, and a lifetime-buy period is in effect.

NRND: Not recommended for new designs. Device is in production to support existing customers, but TI does not recommend using this part in a new design.

PREVIEW: Device has been announced but is not in production. Samples may or may not be available.

OBSELETE: TI has discontinued the production of the device.

(2) Eco Plan - The planned eco-friendly classification: Pb-Free (RoHS), Pb-Free (RoHS Exempt), or Green (RoHS & no Sb/Br) - please check <http://www.ti.com/productcontent> for the latest availability information and additional product content details.

TBD: The Pb-Free/Green conversion plan has not been defined.

Pb-Free (RoHS): TI's terms "Lead-Free" or "Pb-Free" mean semiconductor products that are compatible with the current RoHS requirements for all 6 substances, including the requirement that lead not exceed 0.1% by weight in homogeneous materials. Where designed to be soldered at high temperatures, TI Pb-Free products are suitable for use in specified lead-free processes.

Pb-Free (RoHS Exempt): This component has a RoHS exemption for either 1) lead-based flip-chip solder bumps used between the die and package, or 2) lead-based die adhesive used between the die and leadframe. The component is otherwise considered Pb-Free (RoHS compatible) as defined above.

Green (RoHS & no Sb/Br): TI defines "Green" to mean Pb-Free (RoHS compatible), and free of Bromine (Br) and Antimony (Sb) based flame retardants (Br or Sb do not exceed 0.1% by weight in homogeneous material)

(3) MSL, Peak Temp. - The Moisture Sensitivity Level rating according to the JEDEC industry standard classifications, and peak solder temperature.

(4) There may be additional marking, which relates to the logo, the lot trace code information, or the environmental category on the device.

(5) Multiple Device Markings will be inside parentheses. Only one Device Marking contained in parentheses and separated by a "-" will appear on a device. If a line is indented then it is a continuation of the previous line and the two combined represent the entire Device Marking for that device.

(6) Lead/Ball Finish - Orderable Devices may have multiple material finish options. Finish options are separated by a vertical ruled line. Lead/Ball Finish values may wrap to two lines if the finish value exceeds the maximum column width.

Important Information and Disclaimer: The information provided on this page represents TI's knowledge and belief as of the date that it is provided. TI bases its knowledge and belief on information provided by third parties, and makes no representation or warranty as to the accuracy of such information. Efforts are underway to better integrate information from third parties. TI has taken and continues to take reasonable steps to provide representative and accurate information but may not have conducted destructive testing or chemical analysis on incoming materials and chemicals. TI and TI suppliers consider certain information to be proprietary, and thus CAS numbers and other limited information may not be available for release.



Distributor of Texas Instruments: Excellent Integrated System Limited

Datasheet of TPS22961DNYR - IC LOAD SWITCH 6A 8WSON

Contact us: sales@integrated-circuit.com Website: www.integrated-circuit.com

PACKAGE OPTION ADDENDUM



www.ti.com

17-Dec-2015

In no event shall TI's liability arising out of such information exceed the total purchase price of the TI part(s) at issue in this document sold by TI to Customer on an annual basis.

TAPE AND REEL INFORMATION

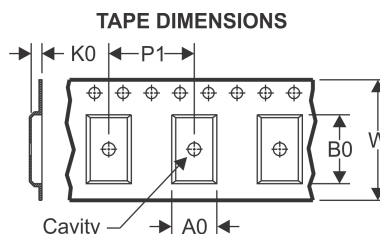
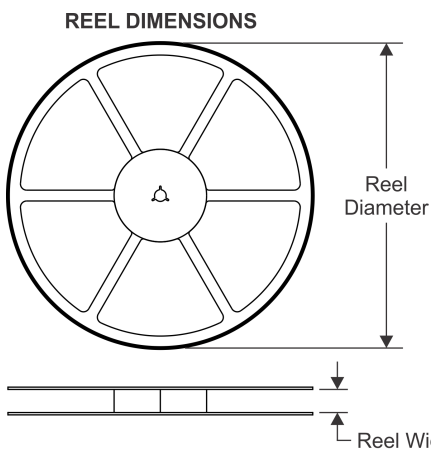

| | |
|----|---|
| A0 | Dimension designed to accommodate the component width |
| B0 | Dimension designed to accommodate the component length |
| K0 | Dimension designed to accommodate the component thickness |
| W | Overall width of the carrier tape |
| P1 | Pitch between successive cavity centers |

QUADRANT ASSIGNMENTS FOR PIN 1 ORIENTATION IN TAPE

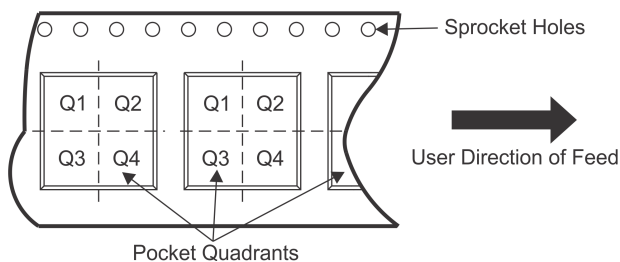

*All dimensions are nominal

| Device | Package Type | Package Drawing | Pins | SPQ | Reel Diameter (mm) | Reel Width W1 (mm) | A0 (mm) | B0 (mm) | K0 (mm) | P1 (mm) | W (mm) | Pin1 Quadrant |
|--------------|--------------|-----------------|------|------|--------------------|--------------------|---------|---------|---------|---------|--------|---------------|
| TPS22961DNYR | WSON | DNY | 8 | 3000 | 330.0 | 12.4 | 3.3 | 3.3 | 1.0 | 8.0 | 12.0 | Q2 |
| TPS22961DNYT | WSON | DNY | 8 | 250 | 180.0 | 12.4 | 3.3 | 3.3 | 1.0 | 8.0 | 12.0 | Q2 |

TAPE AND REEL BOX DIMENSIONS

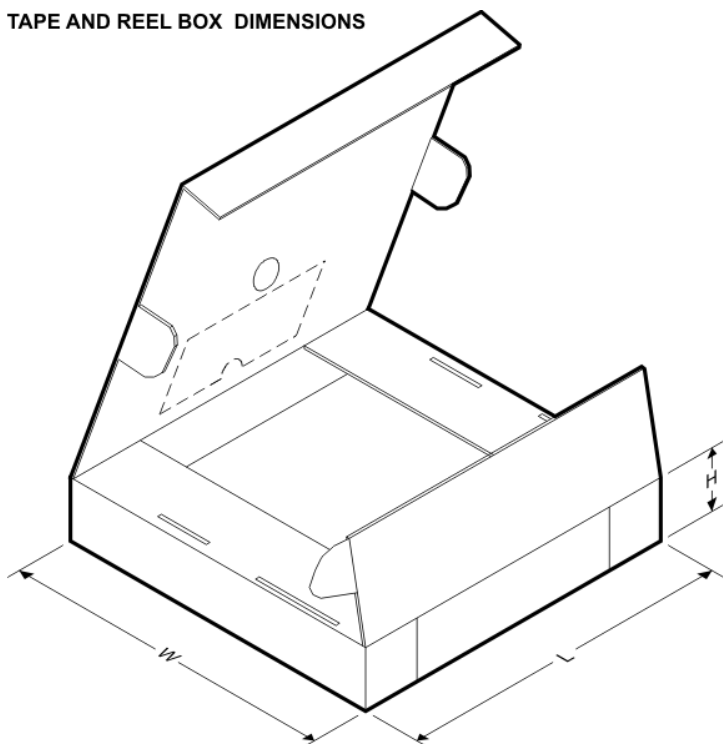

*All dimensions are nominal

| Device | Package Type | Package Drawing | Pins | SPQ | Length (mm) | Width (mm) | Height (mm) |
|--------------|--------------|-----------------|------|------|-------------|------------|-------------|
| TPS22961DNYR | WSON | DNY | 8 | 3000 | 370.0 | 355.0 | 55.0 |
| TPS22961DNYT | WSON | DNY | 8 | 250 | 195.0 | 200.0 | 45.0 |

PACKAGE OUTLINE

DNY0008A

WSON - 0.8 mm max height

PLASTIC SMALL OUTLINE - NO LEAD

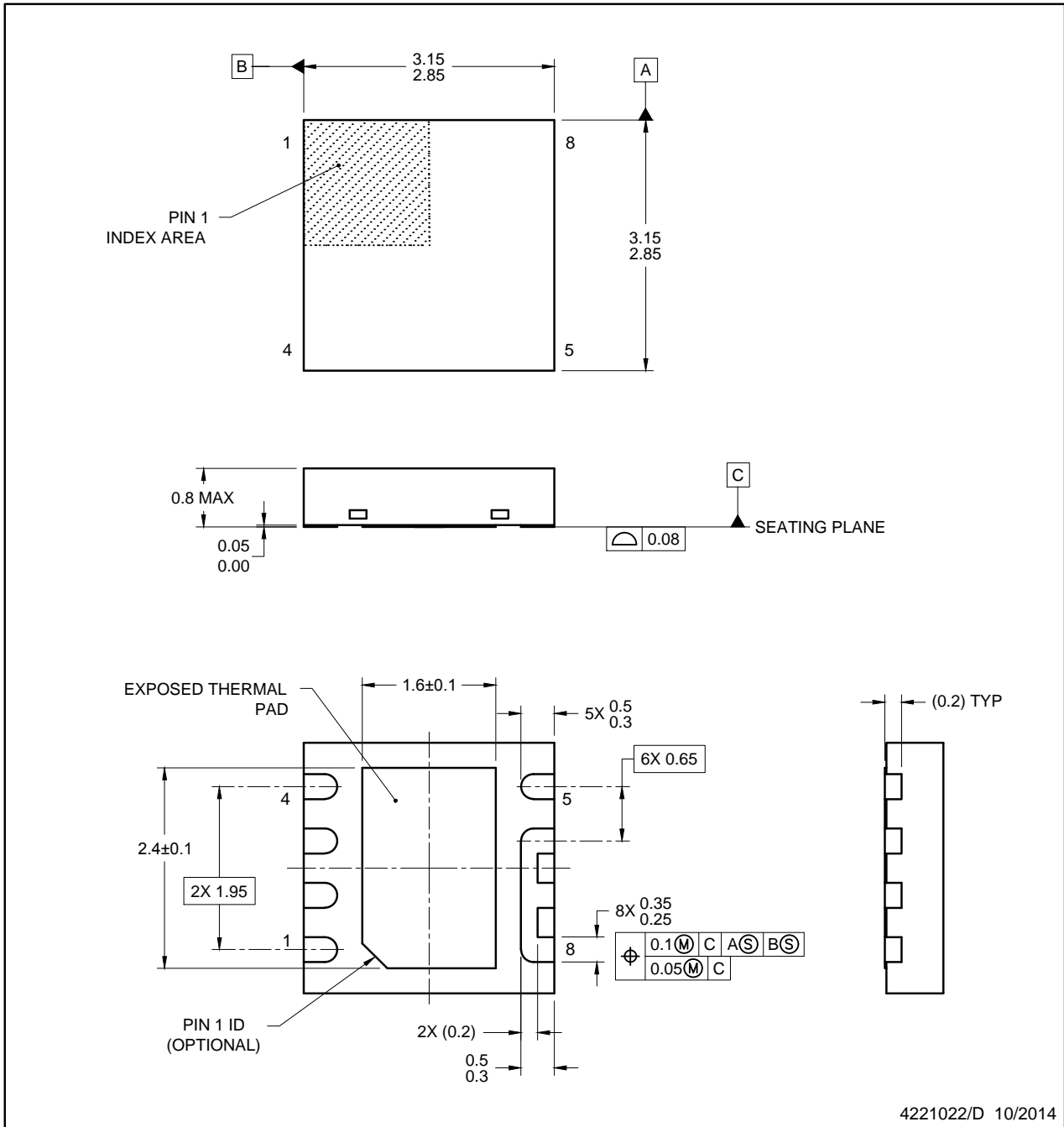

NOTES:

1. All linear dimensions are in millimeters. Any dimensions in parenthesis are for reference only. Dimensioning and tolerancing per ASME Y14.5M.
2. This drawing is subject to change without notice.
3. The package thermal pad must be soldered to the printed circuit board for thermal and mechanical performance.

EXAMPLE BOARD LAYOUT

DNY0008A

WSON - 0.8 mm max height

PLASTIC SMALL OUTLINE - NO LEAD

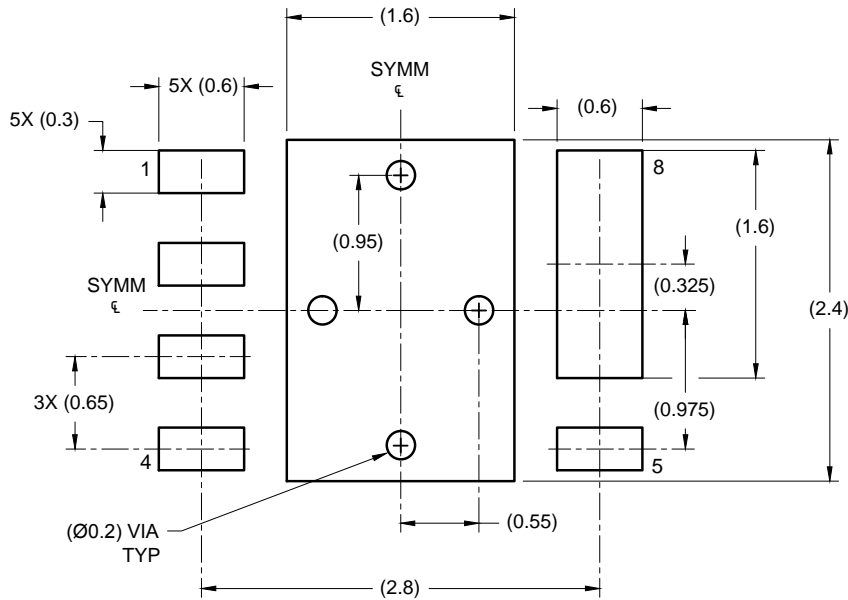

LAND PATTERN EXAMPLE
SCALE: 20X

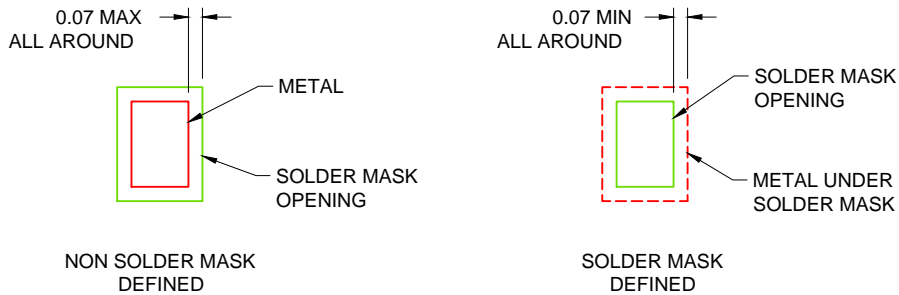

SOLDER MASK DETAILS

4221022/D 10/2014

NOTES: (continued)

4. This package is designed to be soldered to a thermal pad on the board. For more information, see Texas Instruments literature number SLUA271 (www.ti.com/lit/sluea271).
5. Solder mask tolerances between and around signal pads can vary based on board fabrication site.

EXAMPLE STENCIL DESIGN

DNY0008A

WSN - 0.8 mm max height

PLASTIC SMALL OUTLINE - NO LEAD

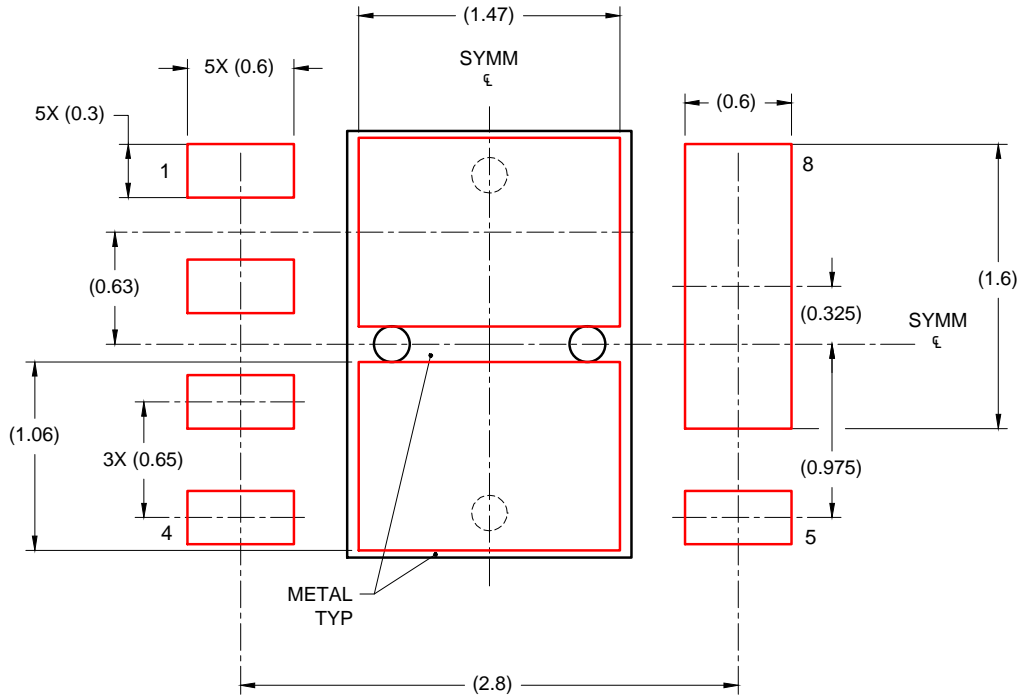

SOLDER PASTE EXAMPLE
BASED ON 0.125 mm THICK STENCIL

EXPOSED PAD
81% PRINTED SOLDER COVERAGE BY AREA
SCALE: 25X

4221022/D 10/2014

NOTES: (continued)

- 6. Laser cutting apertures with trapezoidal walls and rounded corners may offer better paste release. IPC-7525 may have alternate design recommendations.

IMPORTANT NOTICE

Texas Instruments Incorporated and its subsidiaries (TI) reserve the right to make corrections, enhancements, improvements and other changes to its semiconductor products and services per JESD46, latest issue, and to discontinue any product or service per JESD48, latest issue. Buyers should obtain the latest relevant information before placing orders and should verify that such information is current and complete. All semiconductor products (also referred to herein as “components”) are sold subject to TI’s terms and conditions of sale supplied at the time of order acknowledgment.

TI warrants performance of its components to the specifications applicable at the time of sale, in accordance with the warranty in TI’s terms and conditions of sale of semiconductor products. Testing and other quality control techniques are used to the extent TI deems necessary to support this warranty. Except where mandated by applicable law, testing of all parameters of each component is not necessarily performed.

TI assumes no liability for applications assistance or the design of Buyers’ products. Buyers are responsible for their products and applications using TI components. To minimize the risks associated with Buyers’ products and applications, Buyers should provide adequate design and operating safeguards.

TI does not warrant or represent that any license, either express or implied, is granted under any patent right, copyright, mask work right, or other intellectual property right relating to any combination, machine, or process in which TI components or services are used. Information published by TI regarding third-party products or services does not constitute a license to use such products or services or a warranty or endorsement thereof. Use of such information may require a license from a third party under the patents or other intellectual property of the third party, or a license from TI under the patents or other intellectual property of TI.

Reproduction of significant portions of TI information in TI data books or data sheets is permissible only if reproduction is without alteration and is accompanied by all associated warranties, conditions, limitations, and notices. TI is not responsible or liable for such altered documentation. Information of third parties may be subject to additional restrictions.

Resale of TI components or services with statements different from or beyond the parameters stated by TI for that component or service voids all express and any implied warranties for the associated TI component or service and is an unfair and deceptive business practice. TI is not responsible or liable for any such statements.

Buyer acknowledges and agrees that it is solely responsible for compliance with all legal, regulatory and safety-related requirements concerning its products, and any use of TI components in its applications, notwithstanding any applications-related information or support that may be provided by TI. Buyer represents and agrees that it has all the necessary expertise to create and implement safeguards which anticipate dangerous consequences of failures, monitor failures and their consequences, lessen the likelihood of failures that might cause harm and take appropriate remedial actions. Buyer will fully indemnify TI and its representatives against any damages arising out of the use of any TI components in safety-critical applications.

In some cases, TI components may be promoted specifically to facilitate safety-related applications. With such components, TI’s goal is to help enable customers to design and create their own end-product solutions that meet applicable functional safety standards and requirements. Nonetheless, such components are subject to these terms.

No TI components are authorized for use in FDA Class III (or similar life-critical medical equipment) unless authorized officers of the parties have executed a special agreement specifically governing such use.

Only those TI components which TI has specifically designated as military grade or “enhanced plastic” are designed and intended for use in military/aerospace applications or environments. Buyer acknowledges and agrees that any military or aerospace use of TI components which have **not** been so designated is solely at the Buyer’s risk, and that Buyer is solely responsible for compliance with all legal and regulatory requirements in connection with such use.

TI has specifically designated certain components as meeting ISO/TS16949 requirements, mainly for automotive use. In any case of use of non-designated products, TI will not be responsible for any failure to meet ISO/TS16949.

Products

| | |
|------------------------------|--|
| Audio | www.ti.com/audio |
| Amplifiers | amplifier.ti.com |
| Data Converters | dataconverter.ti.com |
| DLP® Products | www.dlp.com |
| DSP | dsp.ti.com |
| Clocks and Timers | www.ti.com/clocks |
| Interface | interface.ti.com |
| Logic | logic.ti.com |
| Power Mgmt | power.ti.com |
| Microcontrollers | microcontroller.ti.com |
| RFID | www.ti-rfid.com |
| OMAP Applications Processors | www.ti.com/omap |
| Wireless Connectivity | www.ti.com/wirelessconnectivity |

Applications

| | |
|-------------------------------|--|
| Automotive and Transportation | www.ti.com/automotive |
| Communications and Telecom | www.ti.com/communications |
| Computers and Peripherals | www.ti.com/computers |
| Consumer Electronics | www.ti.com/consumer-apps |
| Energy and Lighting | www.ti.com/energy |
| Industrial | www.ti.com/industrial |
| Medical | www.ti.com/medical |
| Security | www.ti.com/security |
| Space, Avionics and Defense | www.ti.com/space-avionics-defense |
| Video and Imaging | www.ti.com/video |

TI E2E Community

e2e.ti.com