

Excellent Integrated System Limited

Stocking Distributor

Click to view price, real time Inventory, Delivery & Lifecycle Information:

[Soberton, Inc.](#)
[GT-0950RP3](#)

For any questions, you can email us directly:
sales@integrated-circuit.com

Product Data Sheet
Part No. GT-0950RP3 Non-Washable Type

DIMENSIONS

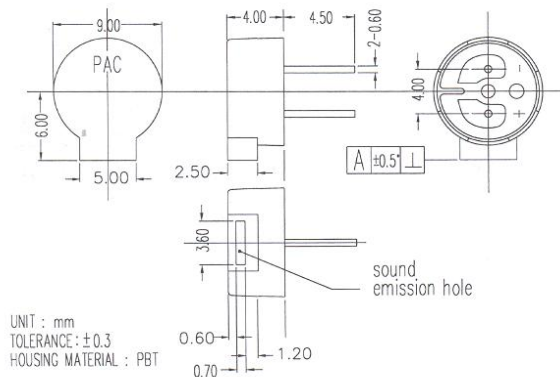

Type	Unit	
Color		Black
Rated Voltage	(V)	5
Operating Voltage	(V)	4-6
Current Consumption	(mA)	MAX.80
Coil Resistance	(Ω)	30±3
Sound Output (Min)	(dB)	90
Resonance Frequency	(Hz)	3100
Operating Temp	(C)	-20~+60
Storage Temp	(C)	-30~+70
Weight	(g)	1
Terminal		PIN TYPE
Dimension	mm	9 x H4
*applied voltage: Rated Voltage, 1/2 duty, square wave		
*distance for measurement: 10cm		

FREQUENCY RESPONSE

