

Excellent Integrated System Limited

Stocking Distributor

Click to view price, real time Inventory, Delivery & Lifecycle Information:

[Advanced Photonix, Inc.](#)
[PDV-V417](#)

For any questions, you can email us directly:

sales@integrated-circuit.com

Silicon Photodiode, Visible Light Detector
Type PDV-V417

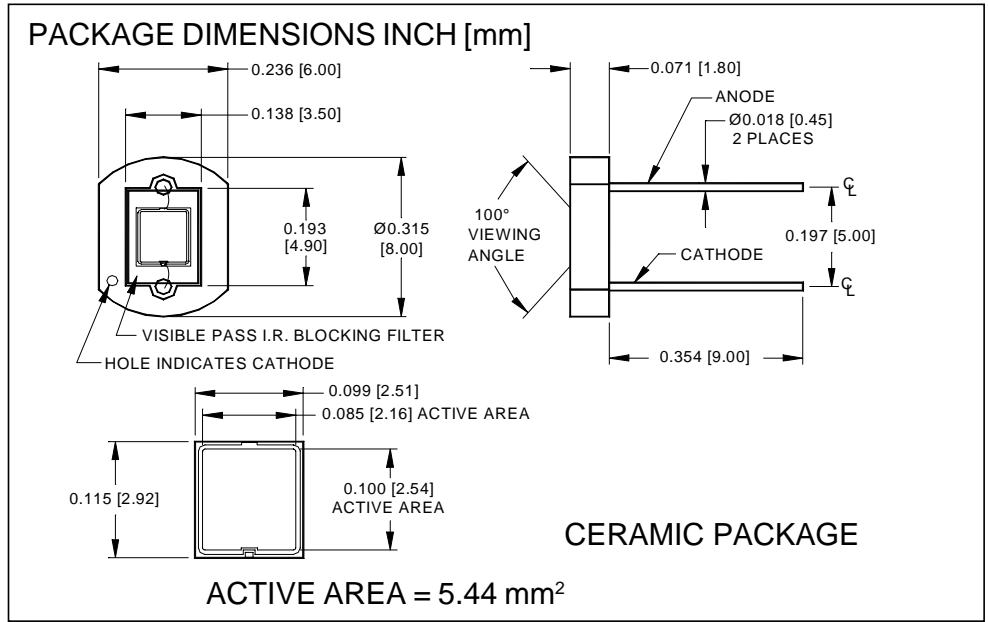

FEATURES

- Visible response
- Low dark current
- Good linearity
- Low noise

DESCRIPTION

The **PDV-V417** is a silicon PIN photodiode, with a built in visible pass, I.R. blocking optical filter. Housed in a black ceramic package with two leads. Designed for photovoltaic operation with 0 volt bias.

APPLICATIONS

- Camera exposure meter
- Light meters
- Visible detector

ABSOLUTE MAXIMUM RATING (TA=25°C unless otherwise noted)

SYMBOL	PARAMETER	MIN	MAX	UNITS
V _{BR}	Reverse Voltage		10	V
T _{STG}	Storage Temperature	-20	+80	°C
T _O	Operating Temperature Range	-20	+60	°C
T _S	Soldering Temperature*		+240	°C
I _L	Light Current		0.5	mA

*1/16 inch from case for 3 secs max

SPECTRAL RESPONSE

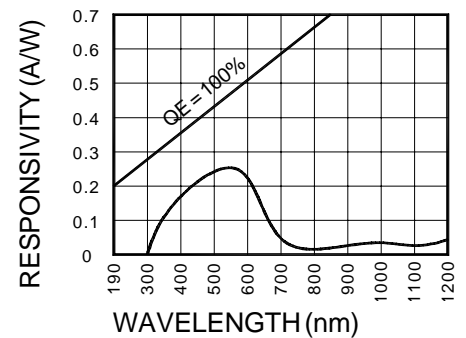

ELECTRO-OPTICAL CHARACTERISTICS (TA=25°C unless otherwise noted)

SYMBOL	CHARACTERISTIC	TEST CONDITIONS	MIN	TYP	MAX	UNITS
I _{SC}	Short Circuit Current	H = 100 fc, 2850 K	5	6.5		μA
I _D	Dark Current	H = 0, V _R = 1 V		3	10	pA
R _{SH}	Shunt Resistance	H = 0, V _R = 10 mV	1.0	1.5		GΩ
TC _{RSH}	R _{SH} Temp. Coefficient	H = 0, V _R = 10 mV		-8		% / °C
C _J	Junction Capacitance	H = 0, V _R = 0 V**		650		pF
λ _{range}	Spectral Application Range	Spot Scan	320		730	nm
λ _p	Spectral Response - Peak	Spot Scan		560		nm
V _{BR}	Breakdown Voltage	I = 10 μA	10	15		V
NEP	Noise Equivalent Power	V _R = 10 V @ Peak		5x10 ⁻¹⁴		W/√Hz
tr	Response Time	RL = 1 KΩ V _R = 10 V		500		nS

Information in this technical data sheet is believed to be correct and reliable. However, no responsibility is assumed for possible inaccuracies or omission. Specifications are subject to change without notice. **f = 1 MHz [FORM NO. 100-PDV-V417 REV A]