

Excellent Integrated System Limited

Stocking Distributor

Click to view price, real time Inventory, Delivery & Lifecycle Information:

[Advanced Photonix, Inc.](#)
[PDI-C105-F](#)

For any questions, you can email us directly:

sales@integrated-circuit.com

PHOTONIC DETECTORS INC.

Silicon Photodiode, Near I.R. Photoconductive Type PDI-C105-F

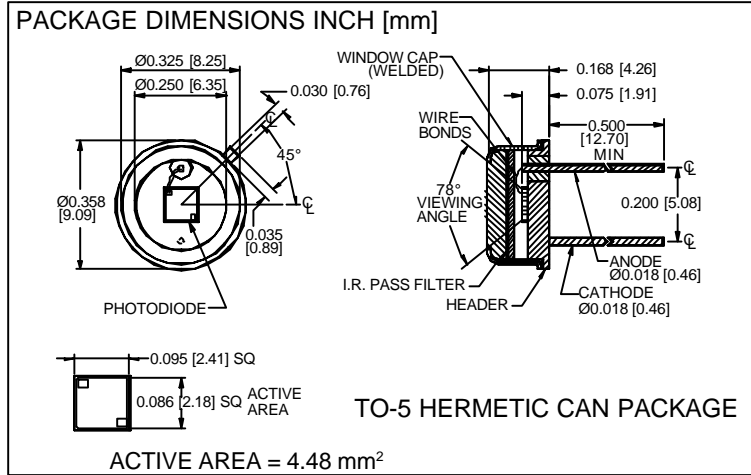

FEATURES

- High speed
- I.R. pass visible rejection
- Match to I.R. emitters
- Hermetic package

DESCRIPTION

The **PDI-C105-F** is a silicon, PIN planar diffused photodiode with NIR pass, visible light rejection optical filter. Ideal for high speed, low capacitance, photoconductive NIR applications. Packaged in a hermetic TO-5 metal can with a flat window cap.

APPLICATIONS

- I.R. detector
- I.R. laser detector
- Photo-interrupters
- Industrial controls

ABSOLUTE MAXIMUM RATING (TA=25°C unless otherwise noted)

SYMBOL	PARAMETER	MIN	MAX	UNITS
V _{BR}	Reverse Voltage		100	V
T _{STG}	Storage Temperature	-55	+100	°C
T _O	Operating Temperature Range	-40	+80	°C
T _S	Soldering Temperature*		+240	°C
I _L	Light Current		0.5	mA

*1/16 inch from case for 3 secs max

SPECTRAL RESPONSE

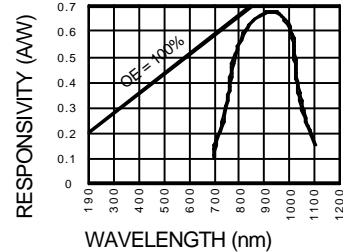

ELECTRO-OPTICAL CHARACTERISTICS (TA=25°C unless otherwise noted)

SYMBOL	CHARACTERISTIC	TEST CONDITIONS	MIN	TYP	MAX	UNITS
I _{SC}	Short Circuit Current	H = 100 fc, 2850 K	36	50		mA
I _D	Dark Current	H = 0, V _R = 10 V		1.0	5.0	nA
R _{SH}	Shunt Resistance	H = 0, V _R = 10 mV	.5	2.0		GΩ
TC R _{SH}	RSH Temp. Coefficient	H = 0, V _R = 10 mV		-8		% / °C
C _J	Junction Capacitance	H = 0, V _R = 10 V**		11		pF
λ _{range}	Spectral Application Range	Spot Scan	700		1100	nm
λ _p	Spectral Response - Peak	Spot Scan		950		nm
V _{BR}	Breakdown Voltage	I = 10 mA	100	125		V
N _{EP}	Noise Equivalent Power	V _R = 10 V @ Peak		2.0x10 ⁻¹⁴		W/√Hz
t _r	Response Time	RL = 1 KΩ V _R = 50 V		12		nS

Information in this technical data sheet is believed to be correct and reliable. However, no responsibility is assumed for possible inaccuracies or omission. Specifications are subject to change without notice. ** f = 1 MHz