

Excellent Integrated System Limited

Stocking Distributor

Click to view price, real time Inventory, Delivery & Lifecycle Information:

[Advanced Photonix, Inc.](#)
[PDB-C119-LC](#)

For any questions, you can email us directly:

sales@integrated-circuit.com

PHOTONIC DETECTORS INC. Silicon Photodiode, Blue Enhanced Photoconductive (OP913SL Industry Equivalent) Lens Type PDB-C119-LC

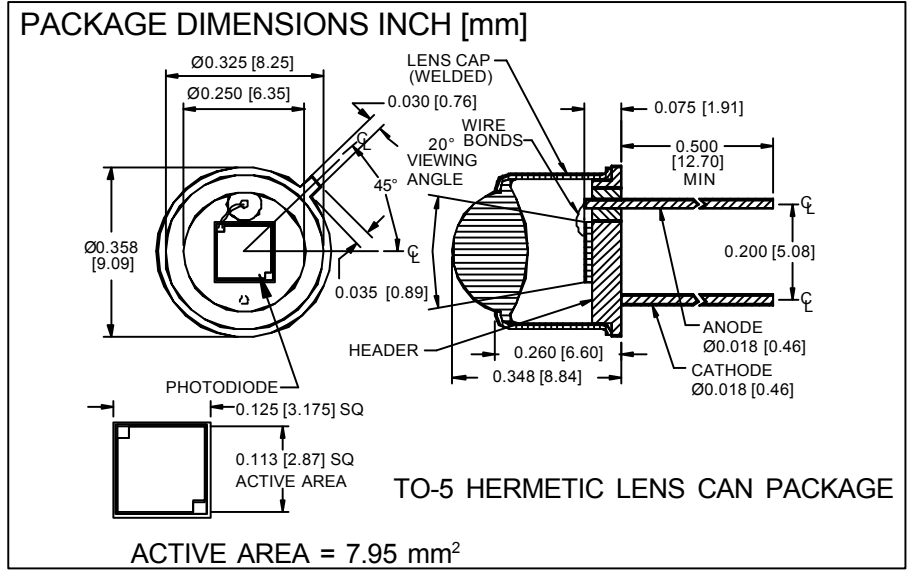
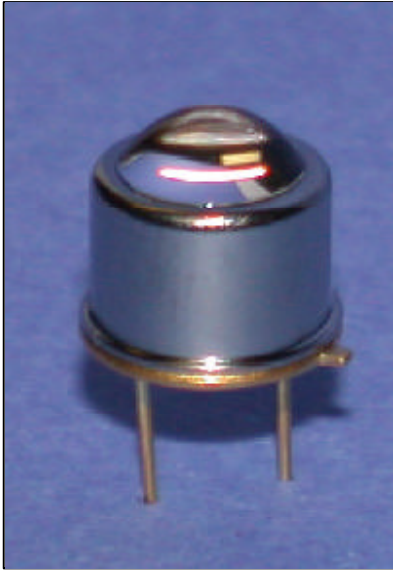

FEATURES

- Narrow angle
- High speed
- Large active area
- Low capacitance

DESCRIPTION

The **PDB-C119-LC** is a silicon, PIN planar diffused, blue enhanced photodiode. Ideal for high speed photoconductive applications. Packaged in a hermetic TO-5 metal can with a glass lens window cap.

APPLICATIONS

- Bar code detector
- Encoder sensor
- Laser detection
- Instrumentation

ABSOLUTE MAXIMUM RATING (TA=25°C unless otherwise noted)

SYMBOL	PARAMETER	MIN	MAX	UNITS
V _{BR}	Reverse Voltage		100	V
T _{STG}	Storage Temperature	-55	+150	°C
T _O	Operating Temperature Range	-40	+125	°C
T _S	Soldering Temperature*		+240	°C
I _L	Light Current		500	mA

*1/16 inch from case for 3 secs max

SPECTRAL RESPONSE

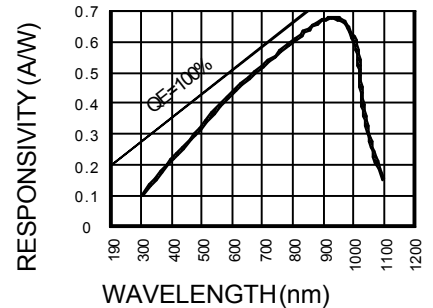

ELECTRO-OPTICAL CHARACTERISTICS (TA=25°C unless otherwise noted)

SYMBOL	CHARACTERISTIC	TEST CONDITIONS	MIN	TYP	MAX	UNITS
I _{SC}	Short Circuit Current	H = 100 fc, 2850 K	90	110		μA
I _D	Dark Current	H = 0, V _R = 10 V		5	20	nA
R _{SH}	Shunt Resistance	H = 0, V _R = 10 mV	150	300		MΩ
TC R _{SH}	RSH Temp. Coefficient	H = 0, V _R = 10 mV		-8		% / °C
C _J	Junction Capacitance	H = 0, V _R = 10 V**		15	20	pF
λ _{range}	Spectral Application Range	Spot Scan	350		1100	nm
λ _p	Spectral Response - Peak	Spot Scan		950		nm
V _{BR}	Breakdown Voltage	I = 10 μA	75	100		V
NEP	Noise Equivalent Power	V _R = 10 V @ Peak		5x10 ⁻¹⁴		W/√Hz
tr	Response Time	RL = 1 KΩ V _R = 10 V		50		nS

Information in this technical data sheet is believed to be correct and reliable. However, no responsibility is assumed for possible inaccuracies or omission. Specifications are subject to change without notice.**f = 1 MHz

[FORMNO. 100-PDB-C119-LCREVB]