

## Excellent Integrated System Limited

Stocking Distributor

Click to view price, real time Inventory, Delivery & Lifecycle Information:

[Advanced Photonix, Inc.](#)  
[PDB-C135](#)

For any questions, you can email us directly:

[sales@integrated-circuit.com](mailto:sales@integrated-circuit.com)

**Silicon Photodiode, Blue Enhanced Photoconductive**  
**Type PDB-C135 , with daylight filter Type PDB-C135F**

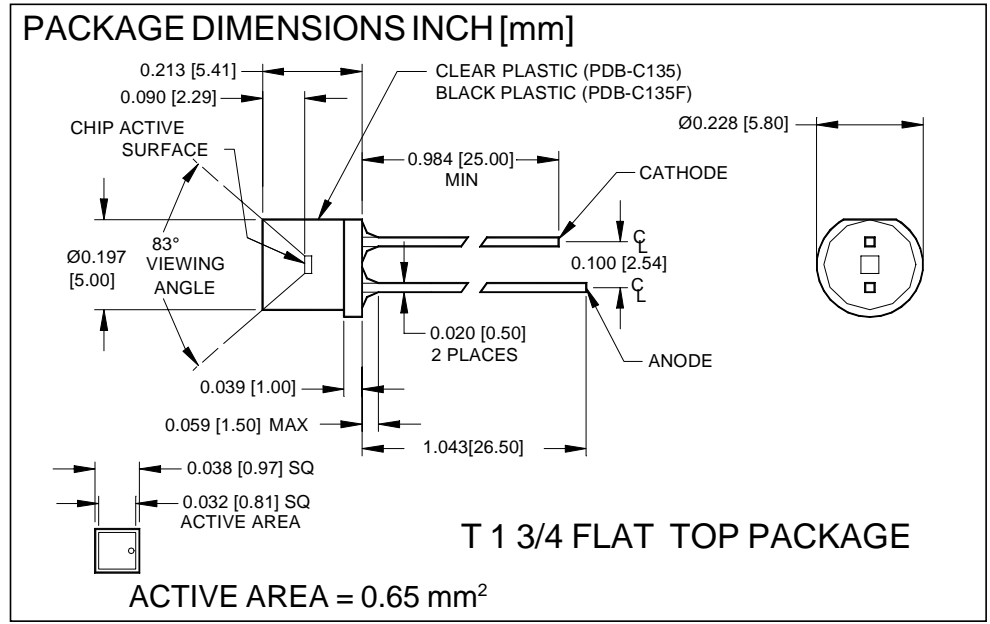

**FEATURES**

- Flat top T 1 3/4
- High speed, 1 nS (tr)
- Low cost

**DESCRIPTION:** The **PDB-C135** detector is a 0.65 mm<sup>2</sup> planar pin photodiode packaged in a T 1 3/4, flat top, water clear plastic housing. Designed for high speed, low capacitance, photoconductive applications. The **PDB-C135F** includes a daylight filter.

**APPLICATIONS**

- Smoke detectors
- Light pen detectors
- TV & VCR remotes

**ABSOLUTE MAXIMUM RATING** (TA=25°C unless otherwise noted)

SYMBOL	PARAMETER	MIN	MAX	UNITS
V <sub>BR</sub>	Reverse Voltage		100	V
T <sub>STG</sub>	Storage Temperature	-40	+100	°C
T <sub>O</sub>	Operating Temperature Range	-40	+80	°C
T <sub>S</sub>	Soldering Temperature*		+260	°C
I <sub>L</sub>	Light Current		0.5	mA

\*1/16 inch from case for 3 secs max

**SPECTRAL RESPONSE**

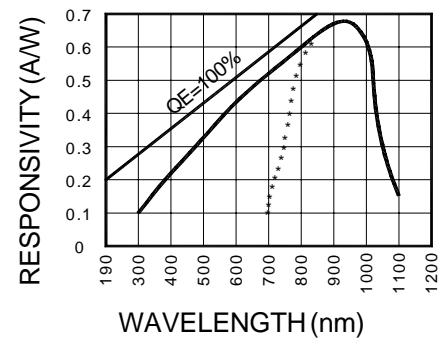

**ELECTRO-OPTICAL CHARACTERISTICS** (TA=25°C unless otherwise noted)

SYMBOL	CHARACTERISTIC	TEST CONDITIONS	MIN	TYP	MAX	UNITS
I <sub>SC</sub>	Short Circuit Current	H = 100 fc, 2850 K	8	10		μA
I <sub>D</sub>	Dark Current	H = 0, V <sub>R</sub> = 10 V		2	10	nA
R <sub>SH</sub>	Shunt Resistance	H = 0, V <sub>R</sub> = 10 mV	.5	5		GΩ
TCR <sub>SH</sub>	RSH Temp. Coefficient	H = 0, V <sub>R</sub> = 10 mV		-8		% / °C
C <sub>J</sub>	Junction Capacitance	H = 0, V <sub>R</sub> = 10 V*		2	5	pF
λ <sub>range</sub>	Spectral Application Range	(without daylight filter)**	400		1100	nm
λ <sub>p</sub>	Spectral Response - Peak			950		nm
V <sub>BR</sub>	Breakdown Voltage	I = 10 μA	50	100		V
NEP	Noise Equivalent Power	V <sub>R</sub> = 10 V @ Peak		1.5x10 <sup>-13</sup>		W/ √Hz
tr	Response Time	RL = 1 KΩ V <sub>R</sub> = 50 V		5		nS

Information in this technical data sheet is believed to be correct and reliable. However, no responsibility is assumed for possible inaccuracies or omission. Specifications are subject to change without notice. \*f = 1 MHz, \*\* daylight filter = 700 - 1100 nm [FORM NO. 100-PDB-C135 REV A]