

Excellent Integrated System Limited

Stocking Distributor

Click to view price, real time Inventory, Delivery & Lifecycle Information:

[Advanced Photonix, Inc.](#)
[PDI-V108-F](#)

For any questions, you can email us directly:

sales@integrated-circuit.com

PHOTONIC DETECTORS INC.

Silicon Photodiode, Near I.R. Photovoltaic Type PDI-V108-F

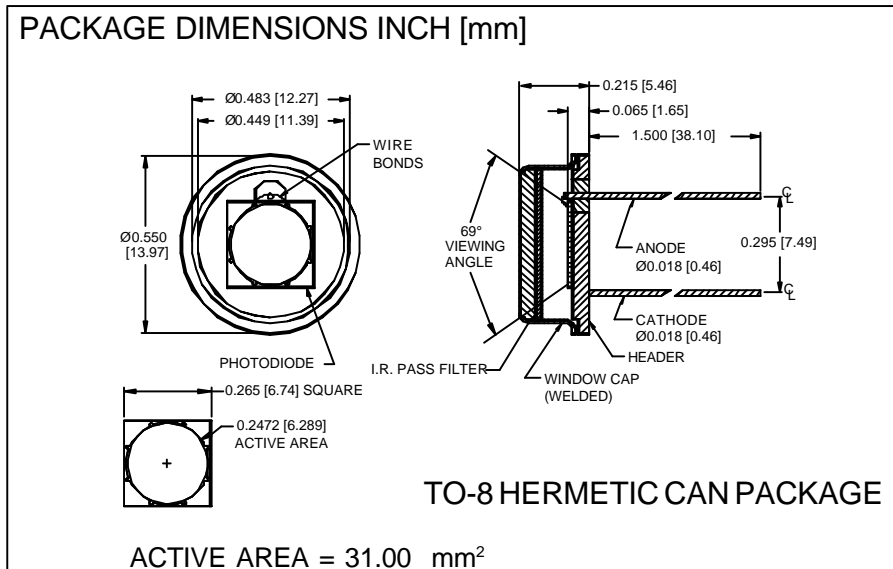

FEATURES

- Low noise
- I.R. pass visible rejection
- Match to I.R. emitters
- Hermetic package

DESCRIPTION

The **PDI-V108-F** is a silicon, PIN planar diffused photodiode with NIR pass, visible light rejection optical filter. Ideal for low noise photovoltaic NIR applications. Packaged in a hermetic TO-8 metal can with a flat window cap.

APPLICATIONS

- I.R. detector
- I.R. laser detector
- Photo-interrupters
- Industrial controls

ABSOLUTE MAXIMUM RATING (TA=25°C unless otherwise noted)

SYMBOL	PARAMETER	MIN	MAX	UNITS
V _{BR}	Reverse Voltage		100	V
T _{STG}	Storage Temperature	-55	+100	°C
T _O	Operating Temperature Range	-40	+80	°C
T _S	Soldering Temperature*		+240	°C
I _L	Light Current		500	mA

*1/16 inch from case for 3 secs max

SPECTRAL RESPONSE

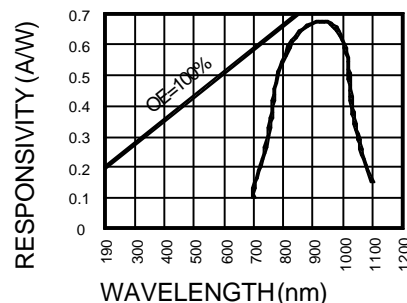

ELECTRO-OPTICAL CHARACTERISTICS (TA=25°C unless otherwise noted)

SYMBOL	CHARACTERISTIC	TEST CONDITIONS	MIN	TYP	MAX	UNITS
I _{SC}	Short Circuit Current	H = 100 fc, 2850 K	338	387		mA
I _D	Dark Current	H = 0, V _R = 10 V		250	800	pA
R _{SH}	Shunt Resistance	H = 0, V _R = 10 mV	.2	1		GΩ
TC R _{SH}	RSH Temp. Coefficient	H = 0, V _R = 10 mV		-8		% / °C
C _J	Junction Capacitance	H = 0, V _R = 0 V**		2500		pF
λ _{range}	Spectral Application Range	Spot Scan	700		1100	nm
λ _p	Spectral Response - Peak	Spot Scan		950		nm
V _{BR}	Breakdown Voltage	I = 10 mA	30	40		V
NEP	Noise Equivalent Power	V _R = 10 mV @ Peak		5x10 ⁻¹⁴		W/√Hz
tr	Response Time	RL = 1 KΩ V _R = 0 V		950		nS

Information in this technical data sheet is believed to be correct and reliable. However, no responsibility is assumed for possible inaccuracies or omission. Specifications are subject to change without notice. **f = 1 MHz