

Excellent Integrated System Limited

Stocking Distributor

Click to view price, real time Inventory, Delivery & Lifecycle Information:

[Advanced Photonix, Inc.](#)
[PDI-E834](#)

For any questions, you can email us directly:

sales@integrated-circuit.com

**PHOTONIC
DETECTORS INC.**

**Three Drive Emitter, Oximeter Component
(660/905 nm) Type PDI-E834**

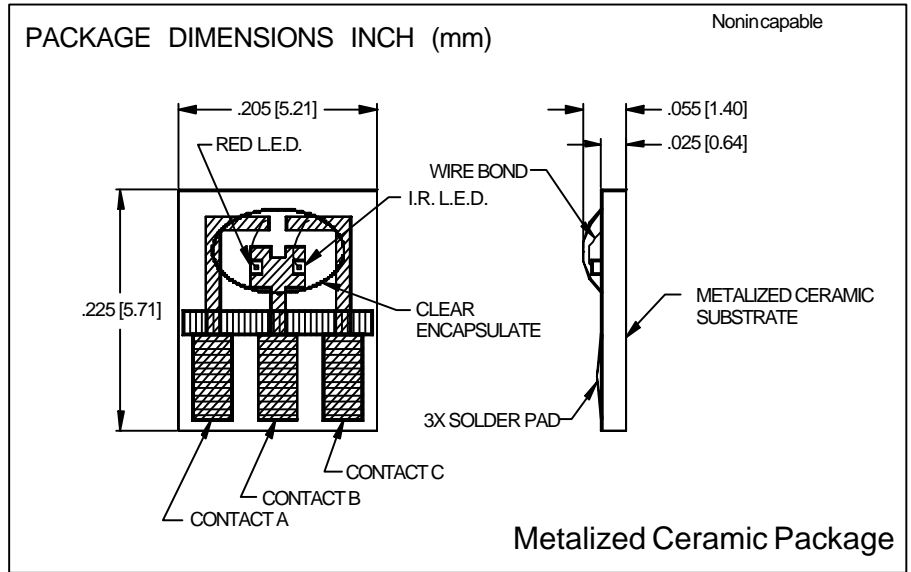
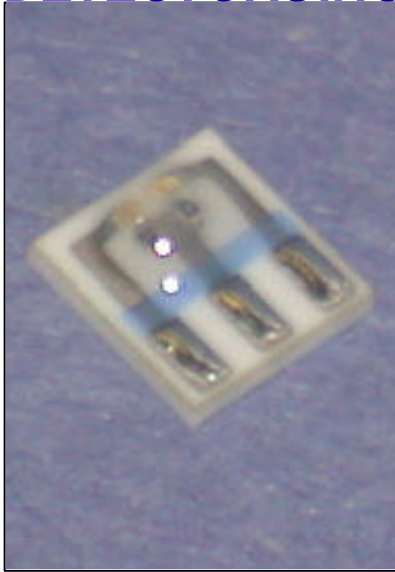

FEATURES

- Low cost
- 660 nm +/- 3 nm
- 3 drive line

DESCRIPTION:

The **PDI-E834** is a three drive line dual emitter oximeter component. The 660 and 905 nm GaAlAs emitters are high power LPE grown. The metalized ceramic has clear epoxy encapsulation with top side solder pads. These components are ideal for O.E.M. and repair replacements of oximeter probe assemblies.

APPLICATIONS

- Oximeter probes
- Finger clamps
- Reusable probes

ABSOLUTE MAXIMUM RATING (TA=25°C unless otherwise noted)

SYMBOL	PARAMETER	MIN	MAX	UNITS
P _d	Power Dissipation I _F =20 mA		250	mW
I _{FP}	Continuous Forward Current		30	mA
I _{FP}	Peak Forward Current		200	mA
V _R	Reverse Voltage		4	V
T _o & T _s	Storage & Operating Temp	-40	+80	°C
TS	Soldering Temperature*		240	°C

* For 3seconds max using a heat sink.

SCHEMATIC

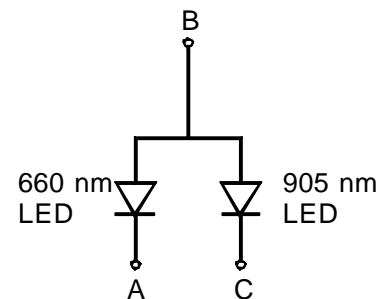

ELECTRO-OPTICAL CHARACTERISTICS (TA=25°C unless otherwise noted)

SYMBOL	CHARACTERISTIC	TEST CONDITIONS	660 nm			905 nm			UNITS
			MIN	TYP	MAX	MIN	TYP	MAX	
P _o	Radiant Flux**	I _F = 20 mA	1.8	2.4		1.2	1.8		mW
I _v	Luminous Intensity**	I _F = 20 mA	20	30					mcd
V _F	Forward Voltage	I _F = 20 mA		1.8	2.4		1.2	1.5	V
V _R	Reverse breakdown	I _F = 10 μA	5			5			V
λ _p	Peak Wavelength	I _F = 20 mA	658	661	664	895	905	915	nm
Δλ	Spectral Bandwidth	I _F = 20 mA		25			50		nm
T _r	Rise Time	I _F = 20 mA		0.8			0.8		μS
T _r	Fall Time	I _F = 20 mA		0.8			0.8		μS

** Bare chip measured packaged in a flat TO-18/TO-46 header without resin coating or cap.

Information in this technical data sheet is believed to be correct and reliable. However, no responsibility is assumed for possible inaccuracies or omission. Specifications are subject to change without notice. [FORMNO. 100-PDI-E834 REV A]