

## Excellent Integrated System Limited

Stocking Distributor

Click to view price, real time Inventory, Delivery & Lifecycle Information:

[Advanced Photonix, Inc.](#)  
[PDU-C119Q](#)

For any questions, you can email us directly:  
[sales@integrated-circuit.com](mailto:sales@integrated-circuit.com)

# PHOTONIC DETECTORS INC.

## Silicon Photodiode, U.V. Enhanced Photoconductive Type PDU-C119-Q

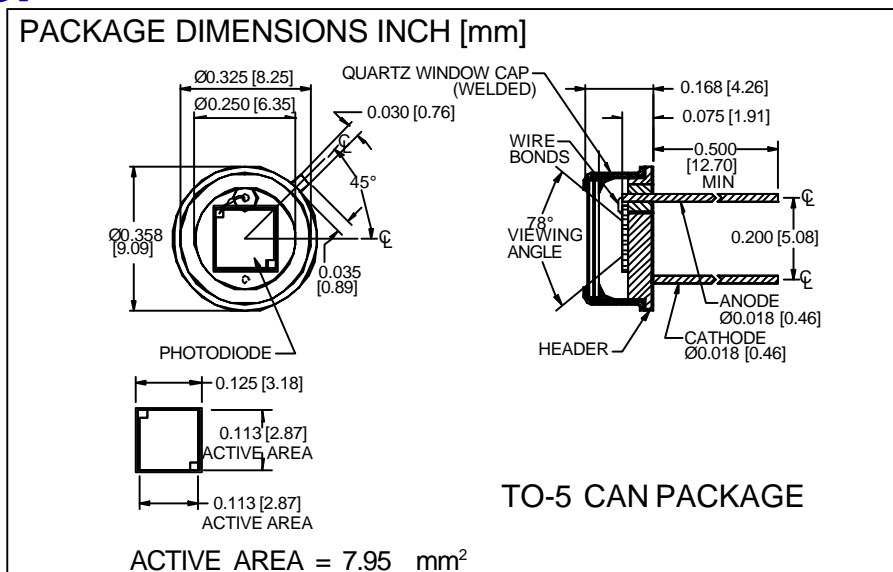

### FEATURES

- High speed
- U.V. enhanced
- Quartz window

### DESCRIPTION

The **PDU-C119-Q** is a silicon, PIN planar diffused, U.V. enhanced photodiode. Ideal for high speed photoconductive U.V. applications. Packaged in a TO-5 metal can with a flat quartz window cap.

### APPLICATIONS

- Spectrometers
- Fluorescent analysers
- U.V. meters
- Colorimeters

### ABSOLUTE MAXIMUM RATING (TA=25°C unless otherwise noted)

SYMBOL	PARAMETER	MIN	MAX	UNITS
V <sub>BR</sub>	Reverse Voltage		30	V
T <sub>STG</sub>	Storage Temperature	-55	+150	°C
T <sub>O</sub>	Operating Temperature Range	-40	+125	°C
T <sub>S</sub>	Soldering Temperature*		+240	°C
I <sub>L</sub>	Light Current		500	mA

\*1/16 inch from case for 3 secs max

### SPECTRAL RESPONSE

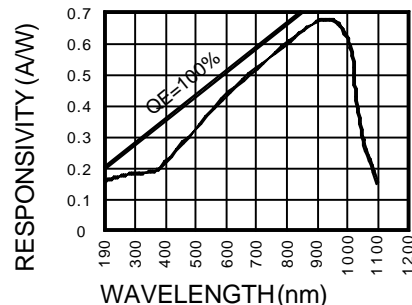

### ELECTRO-OPTICAL CHARACTERISTICS (TA=25°C unless otherwise noted)

SYMBOL	CHARACTERISTIC	TEST CONDITIONS	MIN	TYP	MAX	UNITS
I <sub>SC</sub>	Short Circuit Current	E <sub>c</sub> = 0.1 mW/cm <sup>2</sup> , λ = 350 nm	.6	1.0		μA
I <sub>D</sub>	Dark Current	H = 0, V <sub>R</sub> = 5 V		2.5	5	nA
R <sub>SH</sub>	Shunt Resistance	H = 0, V <sub>R</sub> = 10 mV	150	300		MΩ
TC R <sub>SH</sub>	RSH Temp. Coefficient	H = 0, V <sub>R</sub> = 10 mV		-8		% / °C
C <sub>J</sub>	Junction Capacitance	H = 0, V <sub>R</sub> = 5 V**		130		pF
λ <sub>range</sub>	Spectral Application Range	Spot Scan	190		1100	nm
R	Responsivity	V <sub>R</sub> = 0 V, λ = 254 nm	.12	.18		A/W
V <sub>BR</sub>	Breakdown Voltage	I = 10 μA	15	25		V
NEP	Noise Equivalent Power	V <sub>R</sub> = 10 mV @ Peak		2.2x10 <sup>-14</sup>		W/√Hz
tr	Response Time	RL = 1 KΩ V <sub>R</sub> = 5 V		58		nS

Information in this technical data sheet is believed to be correct and reliable. However, no responsibility is assumed for possible inaccuracies or omission. Specifications are subject to change without notice. \*\*f = 1 MHz

[FORMNO. 100-PDU-C119-QREVA]