

## Excellent Integrated System Limited

Stocking Distributor

Click to view price, real time Inventory, Delivery & Lifecycle Information:

[Advanced Photonix, Inc.](#)  
[PDU-V105Q](#)

For any questions, you can email us directly:

[sales@integrated-circuit.com](mailto:sales@integrated-circuit.com)

# PHOTONIC DETECTORS INC.

## Silicon Photodiode, U.V. Enhanced Photovoltaic Type PDU-V105-Q

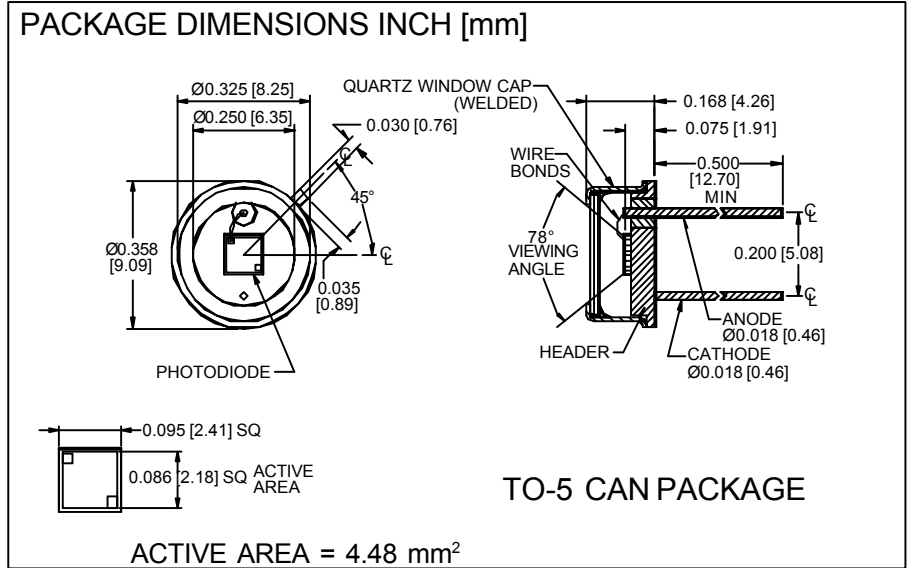

### FEATURES

- Low noise
- U.V. enhanced
- High shunt resistance
- Quartz window

### DESCRIPTION

The **PDU-V105-Q** is a silicon, PIN planar diffused, U.V. enhanced photodiode. Ideal for low noise photovoltaic applications. Packaged in a TO-5 metal can with a flat quartz window.

### APPLICATIONS

- Spectrometers
- Fluorescent analysers
- U.V. meters
- Colorimeters

### ABSOLUTE MAXIMUM RATING (TA=25°C unless otherwise noted)

SYMBOL	PARAMETER	MIN	MAX	UNITS
V <sub>BR</sub>	Reverse Voltage		75	V
T <sub>STG</sub>	Storage Temperature	-55	+150	°C
T <sub>O</sub>	Operating Temperature Range	-40	+125	°C
T <sub>S</sub>	Soldering Temperature*		+240	°C
I <sub>L</sub>	Light Current		500	mA

\*1/16 inch from case for 3 secs max

### SPECTRAL RESPONSE

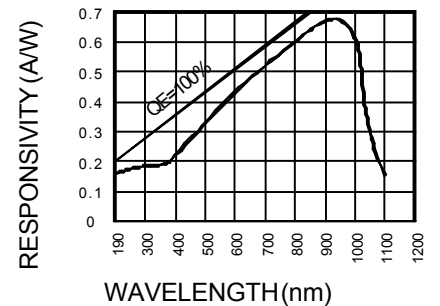

### ELECTRO-OPTICAL CHARACTERISTICS (TA=25°C unless otherwise noted)

SYMBOL	CHARACTERISTIC	TEST CONDITIONS	MIN	TYP	MAX	UNITS
I <sub>SC</sub>	Short Circuit Current	H = 100 fc, 2850 K	30	50		μA
I <sub>D</sub>	Dark Current	H = 0, V <sub>R</sub> = 10 mV		2	5	pA
R <sub>SH</sub>	Shunt Resistance	H = 0, V <sub>R</sub> = 10 mV	2	5		GΩ
TC R <sub>SH</sub>	RSH Temp. Coefficient	H = 0, V <sub>R</sub> = 10 mV		-8		% / °C
C <sub>J</sub>	Junction Capacitance	H = 0, V <sub>R</sub> = 0 V**		500		pF
λ <sub>range</sub>	Spectral Application Range	Spot Scan	190		1100	nm
R	Responsivity	V <sub>R</sub> = 0 V, λ = 254 nm	.12	.18		A/W
V <sub>BR</sub>	Breakdown Voltage	I = 10 μA	5	10		V
NEP	Noise Equivalent Power	V <sub>R</sub> = 10 mV @ Peak		.5x10 <sup>-14</sup>		W/√Hz
tr	Response Time	RL = 1 KΩ V <sub>R</sub> = 0 V		500		nS

Information in this technical data sheet is believed to be correct and reliable. However, no responsibility is assumed for possible inaccuracies or omission. Specifications are subject to change without notice. \*\*f = 1 MHz [FORM NO. 100-PDU-V105-Q REV N/C]