

## Excellent Integrated System Limited

Stocking Distributor

Click to view price, real time Inventory, Delivery & Lifecycle Information:

[Molex Connector Corporation](#)  
[0639027100](#)

For any questions, you can email us directly:

[sales@integrated-circuit.com](mailto:sales@integrated-circuit.com)

Fine Adjust for 2.30mm (.090") Sealed Female Terminal



## FineAdjust Applicator Applicator Tooling Specification Sheet Order No. 63902-7100

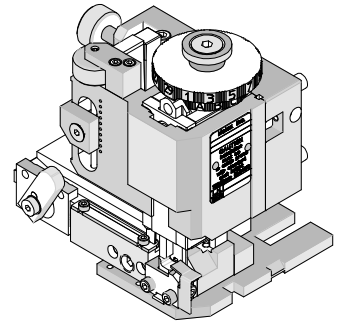

### FEATURES

- Quick punch removal with the push of a button for fast and easy tooling change
- Applicator designed to industry standard mounting and shut height 135.80mm (5.346")
- Quick set-up time; plus the crimp height, track and feed adjustments can be set without removing the applicator from the press
- Fine adjustment allows users to achieve target with little effort by adjusting in increments of .015mm (.0006") for conductor crimp height and .063mm (.0025") for insulation height
- Independent adjustment rings allow users to quickly adjust the conductor or insulation crimp height without affecting each other
- Directly adapts to most automatic wire processing machines

### SCOPE

Products: 2.30mm (.090") Sealed Female Terminal, 0.85-1.25 mm<sup>2</sup> metric wire.

Terminal Series No.	Terminal Order No.	Wire Size and Type		✗ Insulation Diameter		Strip Length	
		mm <sup>2</sup>	Type	mm	In.	mm	In.
35407	35407-6802	0.85	AVS	2.20-2.30	.087-.091	5.0-5.6	.197-.220
		0.85	AVSS	1.80-1.90	.071-.075	5.0-5.6	.197-.220
		1.25	AVS	2.50-2.60	.098-.102	5.0-5.6	.197-.220
		1.25	AVSS	2.10-2.20	.083-.087	5.0-5.6	.197-.220

✗ See crimp specification for the individual Insulation Diameter.

### DEFINITION OF TERMS

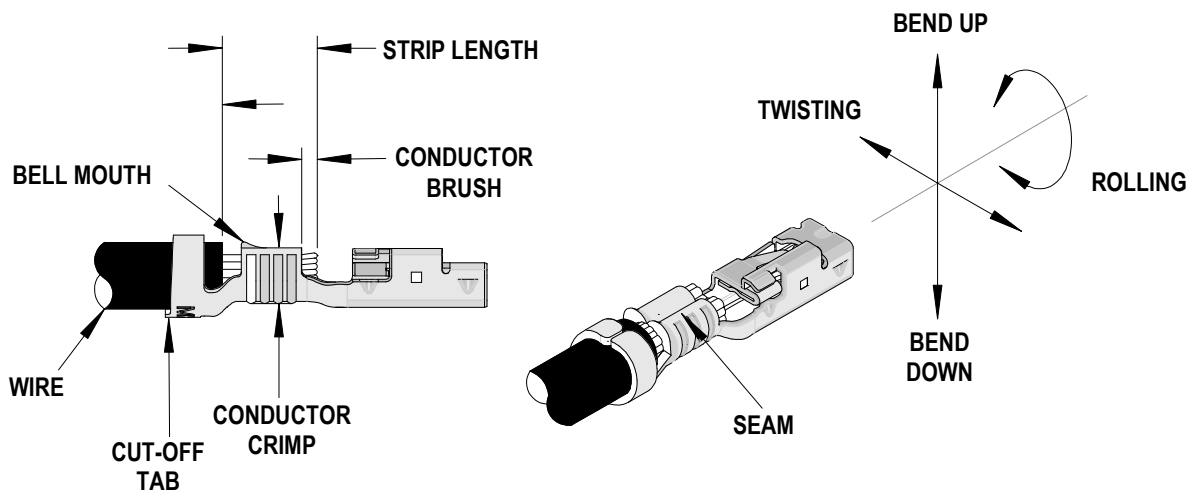

Fine Adjust for 2.30mm (.090") Sealed Female Terminal

### CRIMP SPECIFICATION

Terminal Series No.	Bell mouth		Cut-off Tab Maximum		▶ Conductor Brush	
	mm	In.	mm	In.	mm	In.
35407	0.30-0.60	.012-.024	0.30	.012	0.30-0.80	.012-.032

▶ Not to exceed above the conductor crimp height.

Terminal Series No.	Bend up	Bend down	Twist	Roll	Punch Width (Ref)				Seam Seam shall not be open and no wire allowed out of the crimping area
	Degree		Degree		Conductor		Insulation		
					mm	In	mm	In	
35407	3	3	3	5	1.90	.075	3.80	.150	

After crimping, the crimp profiles should measure the following:

Terminal Series No.	Wire Size	Conductor				Pull Force Minimum	
		Crimp Height		Crimp Width (Ref.)		N	Lb.
	mm <sup>2</sup>	mm	In.	mm	In.		
35407	0.85	1.14-1.26	.045-.050	1.90-2.10	.075-.083	127.5	28.66
	1.25	1.30-1.42	.051-.056	1.90-2.10	.075-.083	166.7	37.48

Terminal Series No.	Wire Size and Type		✗ Insulation Diameter		Single Wire Seal		Insulation			
	mm <sup>2</sup>	Type	mm	In.	Order No.	Color	Crimp Height (Ref)		Crimp Width (Ref.)	
							mm	In.	mm	In.
35407	0.85	AVS	2.20-2.30	.087-.091	0359030023	Red	3.60	.142	3.80-4.00	.150-.158
	0.85	AVSS	1.80-1.90	.071-.075			3.50	.138	3.80-4.00	.150-.158
	1.25	AVS	2.50-2.60	.098-.102			3.70	.146	3.80-4.00	.150-.158
	1.25	AVSS	2.10-2.20	.083-.087			3.60	.142	3.80-4.00	.150-.158

▶ Tool Qualification Notes:

1. Pull Force should be measured with no influence from the insulation crimp.
2. The above specifications are guidelines to an optimum crimp.

Fine Adjust for 2.30mm (.090") Sealed Female Terminal

## PARTS LIST

Fine Adjust Applicator 63902-7100				
Item	Order No	Engineering No.	Description	Quantity
<b>Perishable Tooling</b>				
	63902-7170	63902-7170	Tool Kit (All "Y" Items)	REF
1	63444-1929	63444-1929	Conductor Punch	1 Y
2	63445-1974	63445-1974	Conductor Anvil	1 Y
3	63454-0139	63454-0139	Insulation Punch	1 Y
4	63445-3853	63445-3853	Insulation Anvil	1 Y
5	63443-0037	63443-0037	Cut-Off Plunger	1 Y
6	63443-0038	63443-0038	Front Plunger Retainer	1 Y
<b>Other Components</b>				
7	11-17-0022	1739-21	Hold Down Spring	1
8	11-18-4083	60707-8	Feed Guide	1
9	11-24-1067	4996-4	Cut-off Plunger Spring	1
10	11-40-4039	8302-5	Front Plunger Striker	1
11	63443-0009	63443-0009	Scrap Chute	1
12	63443-0024	63443-0024	Key	1
13	63443-0090	63443-0090	Wire Stop	1
14	63443-0093	63443-0093	Shank	1
15	63443-1718	63443-1718	18.80mm Height Spacer	1
16	63443-2214	63443-2214	14.00mm Spacer	1
17	63443-2317	63443-2317	3.85mm Spacer	1
18	63443-6123	63443-6123	Rear Cover	1
19	63443-7104	63443-7104	Terminal Hold Down	1
<b>Frame</b>				
20	63800-4901	63800-4901	Top	1
21	63801-3281	63801-3281	Base	1
22	63801-4650	63801-4650	Track	1
<b>Hardware</b>				
23	N/A	N/A	M3 by 6 Long SHCS	2**
24	N/A	N/A	M3 by 6 Long FHCS	1**
25	N/A	N/A	M3 by 8 Long SHCS	1**
26	N/A	N/A	M4 by 6 Long SHCS	2**
27	N/A	N/A	M4 by 12 Long BHCS	2**
28	N/A	N/A	M4 by 50 Long SHCS	2**
29	N/A	N/A	M5 by 12 Long SHCS	1**
30	N/A	N/A	#10-32 by 3/8" Long Flat Point SSS	1**
31	N/A	N/A	#10-32 Hex Jam Nut	1**

\*\* Available from an industrial supply company such as MSC (1-800-645-7270).

Fine Adjust for 2.30mm (.090") Sealed Female Terminal

**Assembly Drawing**

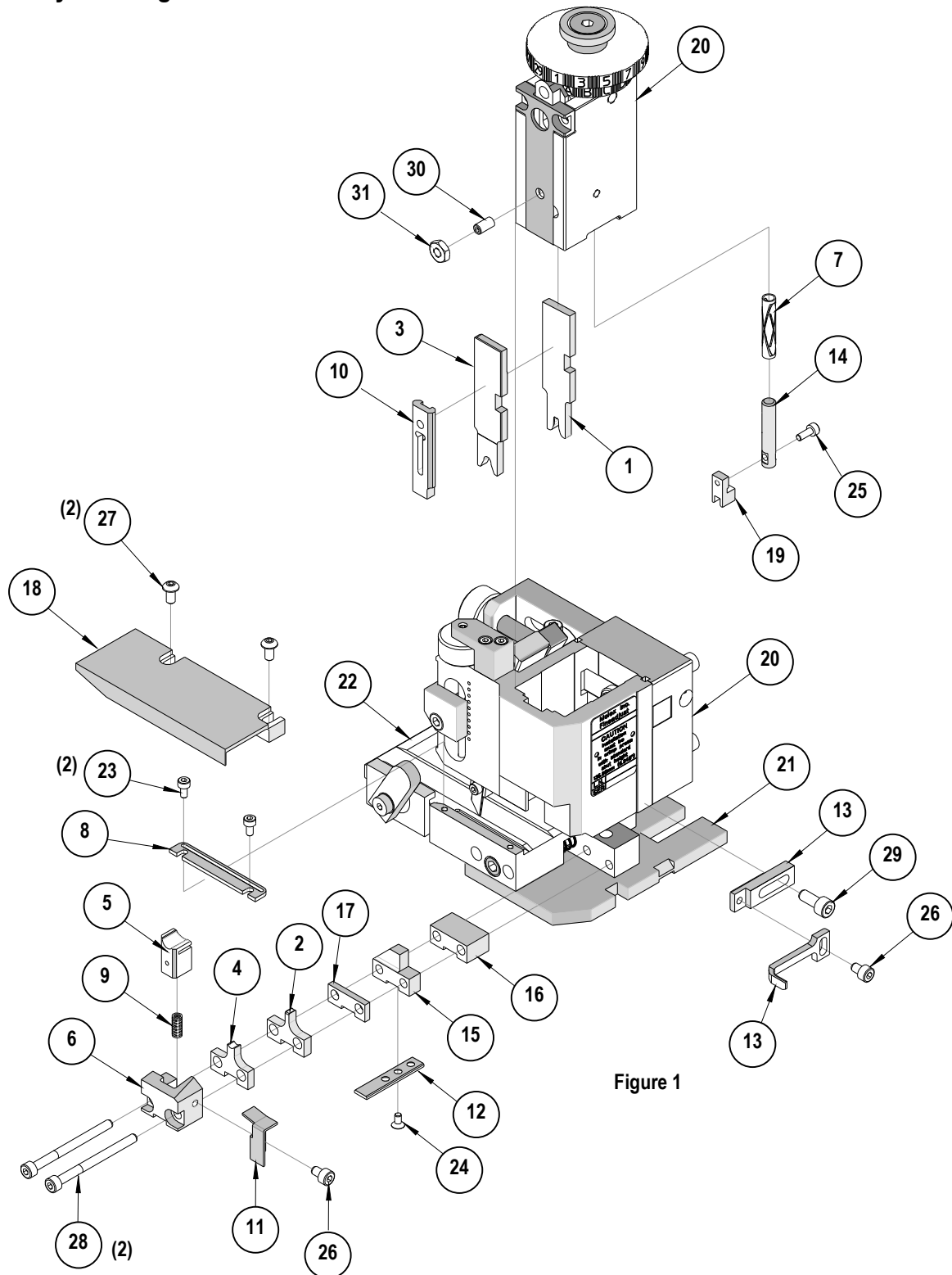

Figure 1

Fine Adjust for 2.30mm (.090") Sealed Female Terminal

## NOTES

1. Molex recommends an extra perishable tooling kit be maintained at your facility.
2. Verify tooling alignment by manually cycling the press and Applicator before crimping under power. Check that all screws are tight.
3. Slugs, Terminals, Dirt and Oil should be kept clear of work area.
4. Wear safety glasses at all times.
5. For recommended maintenance refer to the FineAdjust Manual.

**CAUTION:** This applicator should only be used in a press with a shut height of 135.80 mm (5.346"). Tooling damage could result at a lower setting.

**CAUTION:** To prevent injury never operate this Applicator without the guards supplied with the press or wire-processing machine in place. Reference the press or wire processing manufacturer's instruction manual.

**CAUTION:** Molex crimp specifications are valid only when used with Molex terminals, applicators and tooling.

**Americas Headquarters**  
Lisle, Illinois 60532 U.S.A.  
1-800-78MOLEX  
amerinfo@molex.com

**Far East North Headquarters**  
Yamato, Kanagawa, Japan  
81-462-65-2324  
feninfo@molex.com

**Far East South Headquarters**  
Jurong, Singapore  
65-6-268-6868  
fesinfo@molex.com

**European Headquarters**  
Munich, Germany  
49-89-413092-0  
eurinfo@molex.com

**Corporate Headquarters**  
2222 Wellington Ct.  
Lisle, IL 60532 U.S.A.  
630-969-4550  
Fax: 630-969-1352

Visit our Web site at <http://www.molex.com>