



**Distributor of Amphenol Commercial Products: Excellent Integrated System Limited**  
Datasheet of L177DA15S - D-Sub Connector Receptacle, Female Sockets 15 Position Free  
Hanging (In-Line) Solder Cup

Contact us: [sales@integrated-circuit.com](mailto:sales@integrated-circuit.com) Website: [www.integrated-circuit.com](http://www.integrated-circuit.com)

---

## **Excellent Integrated System Limited**

Stocking Distributor

Click to view price, real time Inventory, Delivery & Lifecycle Information:

[Amphenol Commercial Products](#)  
[L177DA15S](#)

For any questions, you can email us directly:

[sales@integrated-circuit.com](mailto:sales@integrated-circuit.com)

DATE DU TIRAGE

N ETUDE

N OUTIL

N CLIENT

Partie	A	B'	B	C	D'	D	E	F ±0,05	Pds	G	*
boîtier	10,13	16,41	16,09	24,87	8,93	8,43	12,93	10,98	2,74	7,62	2x3
A	10,13	16,41	16,09	24,87	8,93	8,43	12,93	10,98	2,74	7,62	2x5
B	10,13	16,41	16,09	24,87	8,93	8,43	12,93	10,98	2,74	7,62	2x8
C	10,13	16,41	16,09	24,87	8,93	8,43	12,93	10,98	2,74	7,62	2x12
D	10,13	16,41	16,09	24,87	8,93	8,43	12,93	10,98	2,74	7,62	2x12

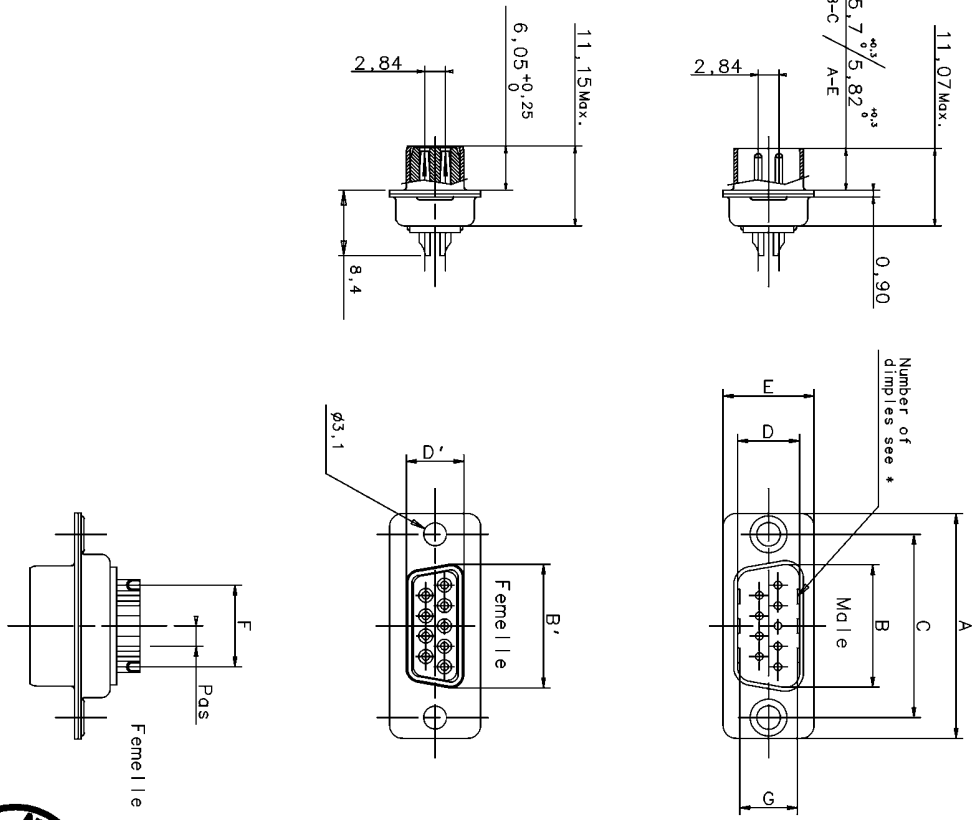

TECHNICAL DATA

'' D '' SUBMINIATURE CONNECTORS

SHELL : Steel .  
 finish : tinned

BODY : Glass filled thermoplastic  
 Flame retardant to UL 94 V-0 .  
 Colour : black .

CONTACTS : Material for sockets : brass  
 Material for pins brass  
 Finish of contact mating area :  
 20µ inch Gold over Nickel

ELECTRICAL Voltage rating : 300 V Rms to 50Hz .  
 Nominal current : 7,5 A (size20)  
 Voltage proof : >1000 V Rms to 50 Hz  
 Contact resistance : <8,5m Ohms .  
 Insulator resistance : >5000 M Ohms .

CLIMATIC Temperature range : -55°C +85°C  
 Damp heat 21 days (40°C - 95 % RH )

MECHANICAL Insertion force per contact : 1,2N < F < 2,5 N  
 Extraction force per contact : 0,4 N mini  
 Mating and unmating force size :  
 A 50N max ; 3,5N mini  
 B 83N max ; 4,5N mini  
 C 123N max ; 8,0N mini  
 D 166N max ; 11,0N mini  
 14,5N mini  
 (With or without dimples)

MARKING Amphenol - ....(serie number)  
 Commercial reference  
 Manufacturing date

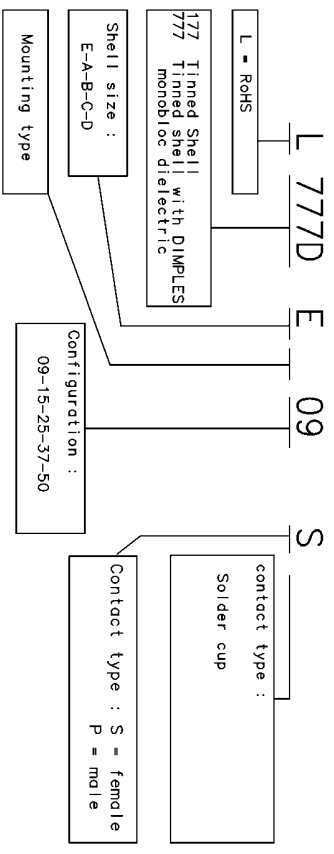

N SERIE	017F	DESIGNATION	L**7D***
Creation plan	23/12/05	DATE	23/12/05
IND. MODIFICATION		DATE	
Amphenol Socapex		Usine de Dole	
PLAN NOTICE		DOSSIER-NOTICE-170	