

Excellent Integrated System Limited

Stocking Distributor

Click to view price, real time Inventory, Delivery & Lifecycle Information:

[Texas Instruments](#)
[TPS2221PWP](#)

For any questions, you can email us directly:

sales@integrated-circuit.com

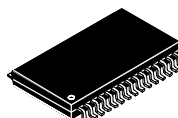
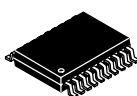
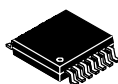

TPS2228
TPS2221

SLVS419C – MAY 2002 REVISED DECEMBER 2008

PC CARD POWER-INTERFACE SWITCH FOR PCMCIA CONTROLLERS

FEATURES

- Provides S-CARD and M-CARD Power Management for CableCARD™ Applications
- Fully Integrated V_{CC} and V_{PP}/V_{CORE} Switching
- Meets PC Card Standards
- V_{PP}/V_{CORE} Output Programmed Independent of V_{CC}
- TTL-Logic Compatible Inputs
- Short Circuit and Thermal Protection
- 20-Pin HTSSOP or 30-Pin SSOP (Dual With Serial Interface) Package
- 14-pin HTSSOP Package (Single With Parallel Interface)
- 95 μA Typ Quiescent Current on 3.3 VIN Input (Dual With Serial Interface)
- 64 μA Typ Quiescent Current on 3.3 VIN Input (Single With Parallel Interface)
- Break-Before-Make Switching
- Power On Reset
- -40°C to 85°C Ambient Operating Temperature Range

APPLICATIONS

- Notebook/Desktop Computers
- Personal Digital Assistants (PDAs)
- Digital Cameras
- Bar-code Scanners

DESCRIPTION

The TPS2228 and TPS2221 PC card power interface switches provide an integrated power management solution for both dual and single PC card sockets. The TPS2228 is a dual-slot power interface switch for serial PCMCIA controllers. The TPS2221 is a single-slot power interface switch for parallel PCMCIA controllers. These power interface switches support the distribution of 3.3 V, 5 V and 1.8 V to the PC card slot while providing current-limiting protection with overcurrent reporting.

ORDERING INFORMATION⁽¹⁾

T _A	PACKAGED DEVICES	
	DUAL HTSSOP, SSOP	SINGLE HTSSOP
-40°C to 85°C	TPS2228PWP (20)	TPS2221PWP (14)
	TPS2228DB (30)	

⁽¹⁾ Both DB and PWP packages are available taped and reeled (indicated by the R suffix on the device type; e.g., TPS2228PWPR).



Please be aware that an important notice concerning availability, standard warranty, and use in critical applications of Texas Instruments semiconductor products and disclaimers thereto appears at the end of this data sheet.

CableCard is a trademark of Cable Television Laboratories, Inc. All other trademarks are the property of their respective owners.

TPS2228
TPS2221

SLVS419C – MAY 2002 REVISED DECEMBER 2008

ABSOLUTE MAXIMUM RATINGS

over operating free-air temperature range unless otherwise noted⁽¹⁾

		TPS2228, TPS2221
Input voltage range for card power	$V_{I(3.3VIN)}$	-0.3 V to 6 V
	$V_{I(5VIN)}$	-0.3 V to 6 V
	$V_{I(1.8VIN)}$	-0.3 V to 6 V
Logic input/output voltage		-0.3 V to 6 V
Output voltage range	$V_{O(XVCC)}$	-0.3 V to 6 V
	$V_{O(XVPP/VCORE)}$	-0.3 V to 6 V
Continuous total power dissipation		See Dissipation Rating Table
Output current	$I_{O(XVCC)}$	Internally Limited
	$I_{O(XVPP/VCORE)}$	
Operating virtual junction temperature range, T_J		-40°C to 100°C
Storage temperature range, T_{stg}		-55°C to 150°C
Lead temperature 1,6 mm (1/16 inch) from case for 10 seconds		260°C
OC sink current		10 mA

⁽¹⁾ Stresses beyond those listed under “absolute maximum ratings” may cause permanent damage to the device. These are stress ratings only, and functional operation of the device at these or any other conditions beyond those indicated under “recommended operating conditions” is not implied. Exposure to absolute-maximum-rated conditions for extended periods may affect device reliability.

DISSIPATION RATINGS TABLE (THERMAL RESISTANCE = °C/W)⁽¹⁾

PACKAGE ⁽²⁾	DERATING FACTOR ABOVE $T_A = 25^\circ\text{C}$	$T_A \leq 25^\circ\text{C}$ POWER RATING	$T_A = 70^\circ\text{C}$ POWER RATING	$T_A = 85^\circ\text{C}$ POWER RATING
20-PWP	30.67 mW/°C	2300 mW	920.25 mW	460.12 mW
14-PWP	26.67 mW/°C	2000 mW	800 mW	400 mW
DB-30	10.95 mW/°C	821.47 mW	328.59 mW	164.3 mW

⁽¹⁾ Reference *Calculating Junction Temperature* in the application information section of this data sheet.

⁽²⁾ These devices are mounted on an JEDEC low-k board (2 oz. traces on surface) (Based on the maximum recommended junction temperature of 100°C)

RECOMMENDED OPERATING CONDITIONS

		MIN	MAX	UNIT
Input voltage, V_I 3.3VIN is required for all circuit operations. 5VIN and 1.8VIN are only required for their respective functions.	$V_{I(3.3VIN)}$	3.0	3.6	V
	$V_{I(5VIN)}$	2.7	5.5	V
	$V_{I(1.8VIN)}$	1.7	5.5	V
Output current	$I_{O(XVCC)}$ at $T_J = 100^\circ\text{C}$		1	A
	$I_{O(XVPP/VCORE)}$ when switched to 5VIN at $T_J = 100^\circ\text{C}$		100	mA
	$I_{O(XVPP/VCORE)}$ when switched to 3.3VIN or 1.8VIN at $T_J = 100^\circ\text{C}$		500	mA
Clock frequency			2.5	MHz
Pulse duration	Data	200		ns
	Latch	250		ns
	Clock	100		ns
	Reset	100		ns
Data to clock hold time (Figure 2)		100		ns
Data to clock setup time (Figure 2)		100		ns
Latch delay time (Figure 2)		100		ns
Clock delay time (Figure 2)		250		ns
Operating virtual junction temperature, T_J (maximum to be calculated at worst case PD at 85°C ambient)		-40	100	°C

ELECTRICAL CHARACTERISTICS

$T_J = -40^\circ\text{C}$ to 100°C , $V_{I(5VIN)} = 5\text{ V}$, $V_{I(3.3VIN)} = 3.3\text{ V}$, $V_{I(1.8VIN)} = 1.8\text{ V}$, all outputs unloaded (unless otherwise noted)⁽¹⁾

PARAMETER		TEST CONDITIONS		MIN	TYP	MAX	UNIT
POWER SWITCH							
Switch resistance	3.3VIN to XVCC with two switches on for dual	$T_J = 25^\circ\text{C}$, $I = 750\text{ mA}$ each		72	95		m Ω
		$T_J = 100^\circ\text{C}$, $I = 750\text{ mA}$ each				120	
	5VIN to XVCC with two switches on for dual	$T_J = 25^\circ\text{C}$, $I = 500\text{ mA}$ each		97	125		m Ω
		$T_J = 100^\circ\text{C}$, $I = 500\text{ mA}$ each				160	
	1.8VIN to XVPP/VCORE with two switches on for dual	$T_J = 25^\circ\text{C}$, $I = 375\text{ mA}$ each		69	95		m Ω
		$T_J = 100^\circ\text{C}$, $I = 375\text{ mA}$ each				120	
	3.3VIN to XVPP/VCORE with two switches on for dual	$T_J = 25^\circ\text{C}$, $I = 250\text{ mA}$ each		196	260		m Ω
		$T_J = 100^\circ\text{C}$, $I = 250\text{ mA}$ each				325	
	5VIN to XVPP/VCORE with two switches on for dual	$T_J = 25^\circ\text{C}$, $I = 100\text{ mA}$ each		0.9	1.3		Ω
		$T_J = 100^\circ\text{C}$, $I = 100\text{ mA}$ each				1.6	
$R_{O(XVCC)}$ discharge resistance		$I_{\text{discharge}} = 1\text{ mA}$		0.1		0.5	k Ω
$R_{O(XVPP/VCORE)}$ discharge resistance		$I_{\text{discharge}} = 1\text{ mA}$		0.1		0.5	k Ω
I_{OS} Short-circuit output current ⁽¹⁾	$I_{O(XVCC)}$ 3.3VIN or 5VIN to XVCC	Limit (limit is the steady state value.)	T_J at 25°C , output powered into a short	1	1.5		A
			T_J [$-40, 100^\circ\text{C}$], output powered into a short	1		2.5	
	$I_{O(XVPP/VCORE)}$ 5VIN to XVPP/VCORE	Limit	T_J at 25°C , output powered into a short	120	175		mA
			T_J [$-40, 100^\circ\text{C}$], output powered into a short	120		300	
$I_{O(XVPP/VCORE)}$ 1.8VIN or 3.3VIN to XVPP/VCORE	Limit	T_J at 25°C , output powered into a short	500	680		mA	
		T_J [$-40, 100^\circ\text{C}$], output powered into a short	500		1250		
Thermal shutdown	Trip point, T_J	Rising temperature, not in overcurrent condition		155	165		$^\circ\text{C}$
		Overcurrent condition		120	130		
	Hysteresis					10	
Current limit response time ⁽²⁾⁽³⁾			$V_{O(XVCC)} = 5\text{ V}$, $100\text{ m}\Omega$ short to GND, $T_J = 25^\circ\text{C}$		10		μs
			$V_{O(XVCC)} = 3.3\text{ V}$, $100\text{ m}\Omega$ short to GND, $T_J = 25^\circ\text{C}$		20		
			$V_{O(XVPP/VCORE)} = 5\text{ V}$, $100\text{ m}\Omega$ short to GND, $T_J = 25^\circ\text{C}$		2		
			$V_{O(XVPP/VCORE)} = 3.3\text{ V}$, $100\text{ m}\Omega$ short to GND, $T_J = 25^\circ\text{C}$		35		
			$V_{O(XVPP/VCORE)} = 1.8\text{ V}$, $100\text{ m}\Omega$ short to GND, $T_J = 25^\circ\text{C}$		250		
I_I Input Quiescent current	Normal operation of TPS2228	$I_I(3.3VIN)$	$V_{O(XVCC)} = V_{O(XVPP/VCORE)} = V_{I(3.3VIN)}$, Output pins are floated	95	140		μA
		$I_I(5VIN)$		5	10		
		$I_I(1.8VIN)$			5		
	Normal operation of TPS2221	$I_I(3.3VIN)$	$V_{O(XVCC)} = V_{O(XVPP/VCORE)} = V_{I(3.3VIN)}$, Output pins are floated	64	100		μA
		$I_I(5VIN)$		5	10		
		$I_I(1.8VIN)$			5		
	Shutdown mode (based on control data)	$I_I(3.3VIN)$	Output pins are floated			5	μA
	$V_{O(XVCC)} = \text{Hi-Z}$	$I_I(5VIN)$				5	
$V_{O(XVPP/VCORE)} = \text{Hi-Z}$	$I_I(1.8VIN)$				5		

(1) Pulse-testing techniques maintain junction temperature close to ambient temperature; thermal effects must be taken into account separately.

(2) Specified by design, not tested in production.

(3) From application of short to 110% of final current limit.

TPS2228
TPS2221

SLVS419C – MAY 2002 REVISED DECEMBER 2008

ELECTRICAL CHARACTERISTICS (continued)

T_J = -40°C to 100°C, V_{I(5VIN)} = 5 V, V_{I(3.3VIN)} = 3.3 V, V_{I(1.8VIN)} = 1.8 V, all outputs unloaded (unless otherwise noted)⁽¹⁾

PARAMETER		TEST CONDITIONS	MIN	TYP	MAX	UNIT
POWER SWITCH (continued)						
Forward leakage current I _{lkg_FWD} (current measured from output pins to ground)	I _{O(xVCC)}	All switches are in Hi-Z state xVCC and xVPP/VCORE are grounded		1	10	μA
	I _{O(xVPP/VCORE)}			1	10	
Reverse leakage current I _{lkg_RVS} (current measured from output pins going in)	I _{O(3.3VIN)}	All switches are in Hi-Z state, 3.3VIN, 5VIN, and 1.8VIN are grounded V _{O(xVPP/VCORE)} = V _{O(xVCC)} = 5 V		1	10	μA
	I _{O(5VIN)}			1	10	
	I _{O(1.8VIN)}			1	10	

- (1) Pulse-testing techniques maintain junction temperature close to ambient temperature; thermal effects must be taken into account separately.
 (2) Specified by design, not tested in production.
 (3) From application of short to 110% of final current limit.

ELECTRICAL CHARACTERISTICS

T_J = -40°C to 100°C, V_{I(5VIN)} = 5 V, V_{I(3.3VIN)} = 3.3 V, V_{I(1.8VIN)} = 1.8 V, all outputs unloaded (unless otherwise noted)⁽¹⁾

PARAMETER		TEST CONDITIONS ⁽¹⁾	MIN	TYP	MAX	UNIT
LOGIC SECTION (CLOCK, DATA, LATCH, RESET, SHDN, OC, VDO, VD1, VD2, VD3)						
Logic input current	I(RESET) ⁽³⁾	RESET = 5.5 V, sinking or sourcing		0	1	μA
		RESET = 0 V, sourcing	10		30	
	I(SHDN) ⁽³⁾ Or I(SHDN_RST) ⁽³⁾	SHDN or SHDN_RST = 5.5 V, sinking or sourcing		0	1	
		SHDN or SHDN_RST = 0 V, sourcing	10		30	
	I(LATCH) ⁽¹⁾	LATCH = 5.5 V, sinking			50	
LATCH = 0 V, sinking or sourcing				1		
	I(CLOCK, DATA, VD0, VD1, VD2, VD3)	0 V to 5.5 V, sinking or sourcing			1	
Logic input high level ⁽⁴⁾			2			V
Logic input low level ⁽⁴⁾					0.8	
OC output saturation voltage		I _O = 2 mA			0.4	
OC leakage current		V _{O(OC)} = 5.5 V			1	μA
OC deglitch ⁽²⁾	Falling edge	Falling into overcurrent condition	5		15	mS
	Rising edge	Coming out of overcurrent condition	5		15	

PARAMETER		TEST CONDITIONS ⁽¹⁾	MIN	TYP	MAX	UNIT
UVLO						
3.3VIN UVLO		3.3VIN level below which all switches are in Hi-Z state	2.2		2.9	V
3.3VIN Hysteresis ⁽²⁾				0.1		
5VIN UVLO		5VIN level below which only 5VIN switches are in Hi-Z state	2.0		2.6	mV
5VIN Hysteresis ⁽²⁾				80		
1.8VIN UVLO		1.8VIN level below which only 1.8VIN switches are in Hi-Z state	1.25		1.62	V
1.8VIN Hysteresis ⁽²⁾				50		mV

- (1) Refer to Parameter Measurement Information, Figure 1.
 (2) Specified by design, not tested in production.
 (3) RESET and SHDN (or SHDN/RST for TPS2221) have low current pullup; LATCH has low current pulldown.
 (4) For recommended operating ranges only.

ELECTRICAL CHARACTERISTICS

T_J = -40°C to 100°C, V_{I(5VIN)} = 5 V, V_{I(3.3VIN)} = 3.3 V, V_{I(1.8VIN)} = 1.8 V, all outputs unloaded (unless otherwise noted)⁽¹⁾

PARAMETER ⁽¹⁾		TEST CONDITIONS ⁽¹⁾	MIN	TYP	MAX	UNIT	
SWITCHING CHARACTERISTICS							
t _r Output rise times ⁽²⁾	5VIN to xVCC	C _{L(xVCC)} = 0.1 μF, I _{O(xVCC)} = 0 A,	0.5		2	ms	
	3.3VIN to xVCC		0.5		2		
	1.8VIN to xVPP/VCORE	C _{L(xVPP/VCORE)} = 0.1 μF, I _{O(xVPP/VCORE)} = 0 A	0.5		2		
	3.3VIN to xVPP/VCORE		0.15		1		
	5VIN to xVPP/VCORE	C _{L(xVPP/VCORE)} = 0.1 μF, I _{O(xVPP/VCORE)} = 0 A	0.05		0.14		
	5VIN to xVCC		C _{L(xVCC)} = 150 μF, I _{O(xVCC)} = 0.75A	0.75			2.0
	3.3VIN to xVCC	0.75			2.0		
	1.8VIN to xVPP/VCORE	C _{L(xVPP/VCORE)} = 150 μF, I _{O(xVPP/VCORE)} = 0.375A	0.50		2.0		
	3.3VIN to xVPP/VCORE		0.50		1.15		
	5VIN to xVPP/VCORE	C _{L(xVPP/VCORE)} = 10 μF, I _{O(xVPP/VCORE)} = 0.05A	0.15		0.375		
t _f Output fall times ⁽²⁾	5VIN to xVCC	C _{L(xVCC)} = 0.1 μF, I _{O(xVCC)} = 0 A,	0.25		1.0	ms	
	3.3VIN to xVCC		0.35		1.0		
	1.8VIN to xVPP/VCORE	C _{L(xVCC)} = 0.1 μF, I _{O(xVCC)} = 0 A,	0.25		1.0		
	3.3VIN to xVPP/VCORE		0.1		0.5		
	5VIN to xVPP/VCORE	C _{L(xVPP/VCORE)} = 0.1 μF, I _{O(xVPP/VCORE)} = 0 A	0.075		0.15		
	5VIN to xVCC		C _{L(xVCC)} = 150 μF, I _{O(xVCC)} = 0.75A	1.4			2.5
	3.3VIN to xVCC	1.4			1.7		
	1.8VIN to xVPP/VCORE	C _{L(xVCC)} = 150 μF, I _{O(xVPP/VCORE)} = 0.375 A	1.4		2.0		
	3.3VIN to xVPP/VCORE		2.5		3.1		
	5VIN to xVPP/VCORE	C _{L(xVPP/VCORE)} = 10 μF, I _{O(xVPP/VCORE)} = 0.05 A	1.7		2.1		
t _{pd} Propagation delay ⁽²⁾	Latch↑ to xVPP/VCORE (1.8 V)	C _{L(xVPP/VCORE)} = 0.1 μF, I _{O(xVPP/VCORE)} = 0 A	t _{pdon}	0.15		1.4	ms
			t _{pdoff}	2.5		8.6	
	Latch↑ to xVPP/VCORE (3.3 V)	C _{L(xVPP/VCORE)} = 0.1 μF, I _{O(xVPP/VCORE)} = 0 A	t _{pdon}	0.05		0.5	
			t _{pdoff}	0.5		2.5	
	Latch↑ to xVPP/VCORE (5 V)	C _{L(xVPP/VCORE)} = 0.1 μF, I _{O(xVPP/VCORE)} = 0 A	t _{pdon}	0.02		0.3	
			t _{pdoff}	0.10		0.3	
	Latch↑ to xVCC (5 V)	C _{L(xVCC)} = 0.1 μF, I _{O(xVCC)} = 0 A	t _{pdon}	0.15		0.85	
			t _{pdoff}	1.3		3.7	
	Latch↑ to xVCC (3.3 V)	C _{L(xVCC)} = 0.1 μF, I _{O(xVCC)} = 0 A	t _{pdon}	0.15		1.0	
			t _{pdoff}	1.7		5.3	
t _{pd} Propagation delay ⁽²⁾	Latch↑ to xVPP/VCORE (1.8 V)	C _{L(xVPP/VCORE)} = 150 μF, I _{O(xVPP/VCORE)} = 0.375 A	t _{pdon}	0.35		1.9	ms
			t _{pdoff}	2.4		8.5	
	Latch↑ to xVPP/VCORE (3.3 V)	C _{L(xVPP/VCORE)} = 150 μF, I _{O(xVPP/VCORE)} = 0.375 A	t _{pdon}	0.2		0.75	
			t _{pdoff}	0.5		2.5	
	Latch↑ to xVPP/VCORE (5 V)	C _{L(xVPP/VCORE)} = 10 μF, I _{O(xVPP/VCORE)} = 0.05 A	t _{pdon}	0.05		0.15	
			t _{pdoff}	0.15		0.35	
	Latch↑ to xVCC (5 V)	C _{L(xVCC)} = 150 μF, I _{O(xVCC)} = 0.75 A	t _{pdon}	0.35		1.2	
			t _{pdoff}	1.3		3.7	
	Latch↑ to xVCC (3.3 V),	C _{L(xVCC)} = 150 μF, I _{O(xVCC)} = 0.75 A	t _{pdon}	0.4		1.4	
			t _{pdoff}	1.5		5.2	

(1) Refer to Parameter Measurement Information, Figure 1.

(2) Specified by design, not tested in production

TPS2228
TPS2221

SLVS419C – MAY 2002 REVISED DECEMBER 2008

PARAMETER MEASUREMENT INFORMATION

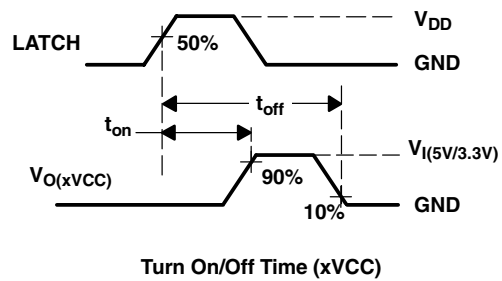
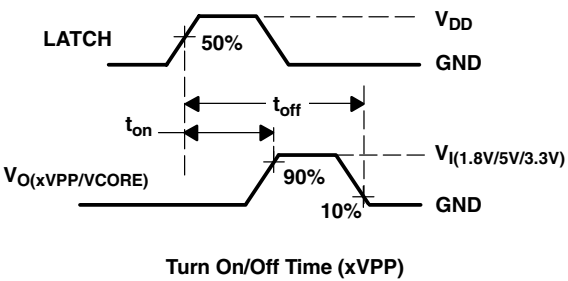
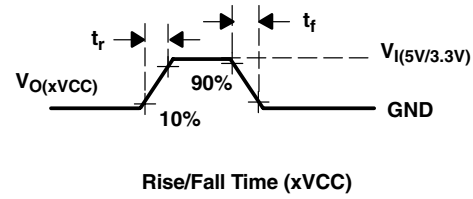
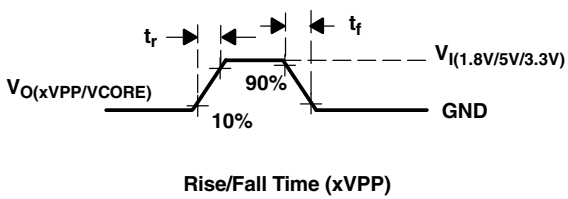
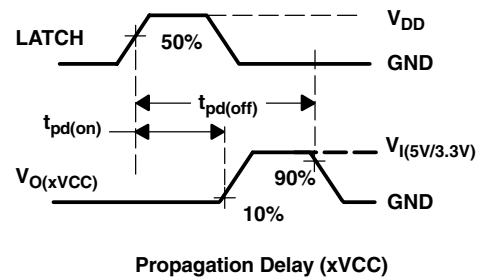
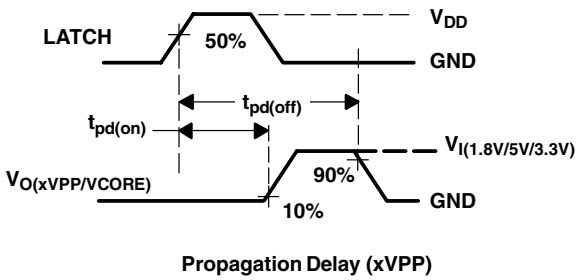
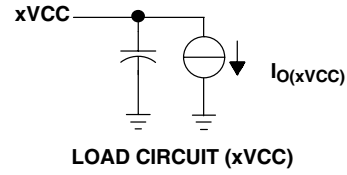
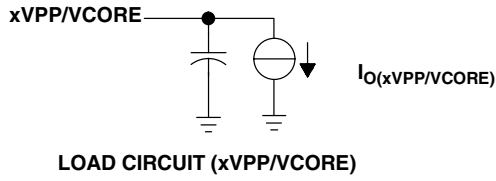

VOLTAGE WAVEFORMS

Figure 1. Test Circuits and Voltage Waveforms

PARAMETER MEASUREMENT INFORMATION

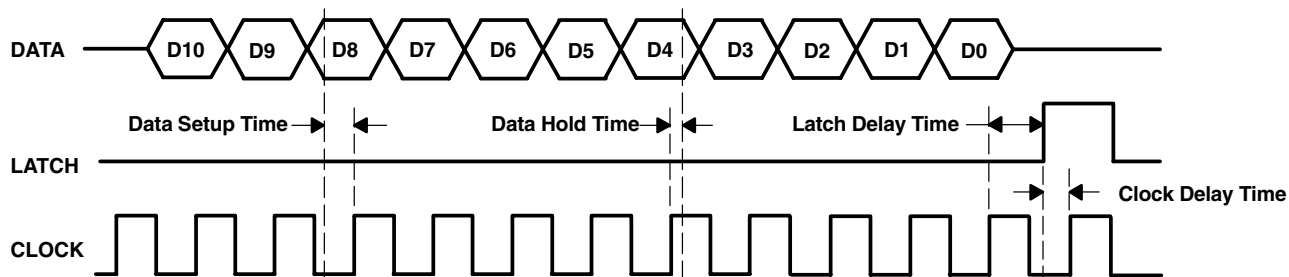

NOTE: Data is clocked in on the positive edge of the clock. The positive edge of the latch signal should occur before the next positive edge of the clock. For definition of D0 to D10, see the control logic table.

Figure 2. Serial-Interface Timing for TPS2228/TPS2221 Power Interface Switch

TABLE OF GRAPHS FOR POWER MEASUREMENT INFORMATION

		FIGURE
Short-Circuit Current Response, Short Applied to Powered-on 5VIN-to-xVCC Switch Output	vs Time	3
Short-Circuit Current Response, Short Applied to Powered-on 3.3VIN-to-xVCC Switch Output	vs Time	4
\overline{OC} Response With 5VIN-to-xVCC Switch Output Turned on Into a Short	vs Time	5
\overline{OC} Response With 3.3VIN-to-xVCC Switch Output Turned on Into a Short	vs Time	6
3.3VIN and 5VIN Input Current	vs Junction Temperature	7
3.3VIN and 5VIN Input Current	vs Junction Temperature	8
1.8VIN Input Current	vs Junction Temperature	9
Static Drain-Source On-State Resistance, 3.3VIN to xVCC Switch	vs Junction Temperature	10
Static Drain-Source On-State Resistance, 5VIN to xVCC Switch	vs Junction Temperature	11
Static Drain-Source On-State Resistance, 3.3VIN to xVPP/VCORE Switch	vs Junction Temperature	12
Static Drain-Source On-State Resistance, 5VIN to xVPP/VCORE Switch	vs Junction Temperature	13
Static Drain-Source On-State Resistance, 1.8VIN to xVPP/VCORE Switch	vs Junction Temperature	14
Short-Circuit Current Limit, 3.3VIN to xVCC Switch	vs Junction Temperature	15
Short-Circuit Current Limit, 5VIN to xVCC Switch	vs Junction Temperature	16
Short-Circuit Current Limit, 3.3VIN to xVPP/VCORE Switch	vs Junction Temperature	17
Short-Circuit Current Limit, 5VIN to xVPP/VCORE Switch	vs Junction Temperature	18
Short-Circuit Current Limit, 1.8VIN to xVPP/VCORE Switch	vs Junction Temperature	19

TPS2228
TPS2221

SLVS419C – MAY 2002 REVISED DECEMBER 2008

PARAMETER MEASUREMENT INFORMATION

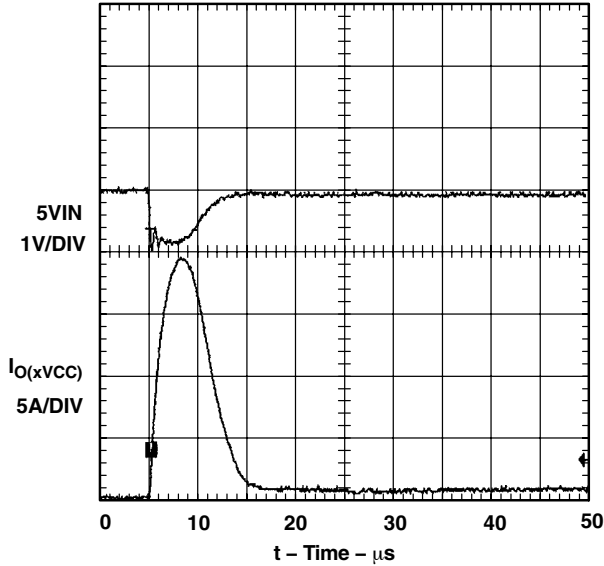

Figure 3. Short-Circuit Response, Short Applied to Powered-on 5VIN-to-xVCC Switch Output

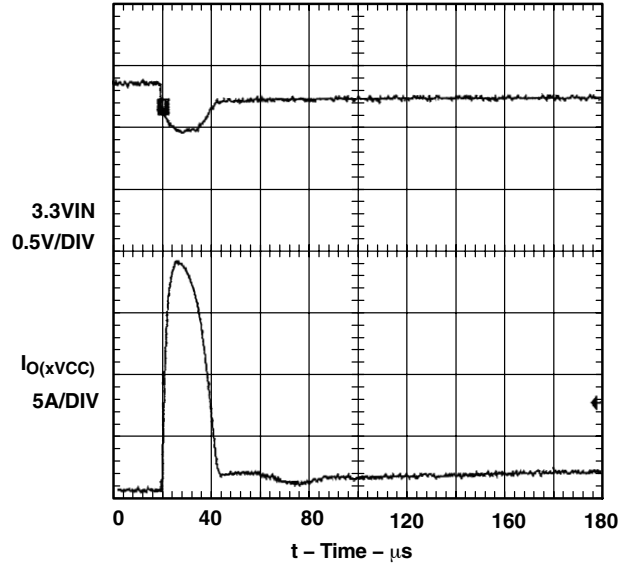

Figure 4. Short-Circuit Response, Short Applied to Powered-on 3.3VIN-to-xVCC-Switch Output

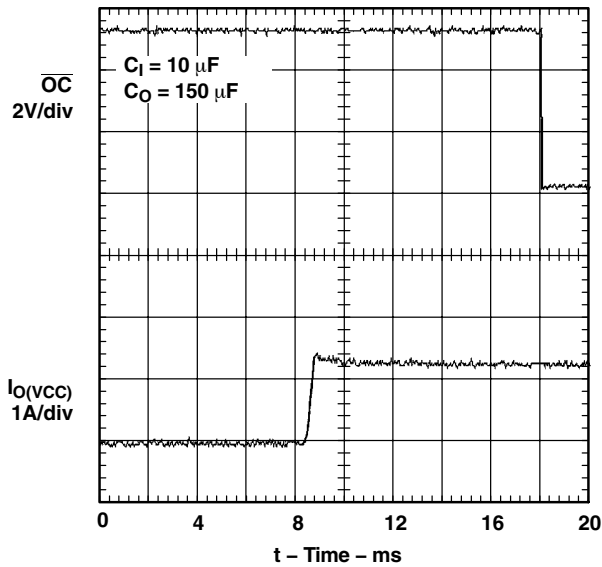

Figure 5. \overline{OC} Response With 5VIN-to-xVCC Switch Output Turned on Into a Short

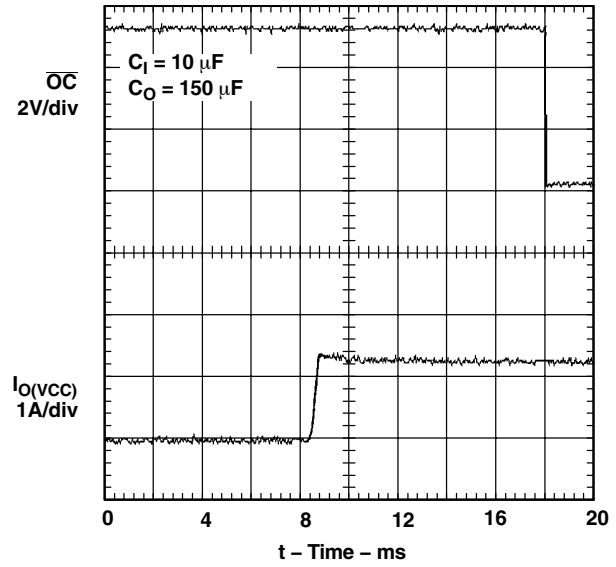

Figure 6. \overline{OC} Response With 3.3VIN-to-xVCC Switch Output Turned on Into a Short

PARAMETER MEASUREMENT INFORMATION

3.3VIN AND 5VIN INPUT CURRENT
vs
JUNCTION TEMPERATURE

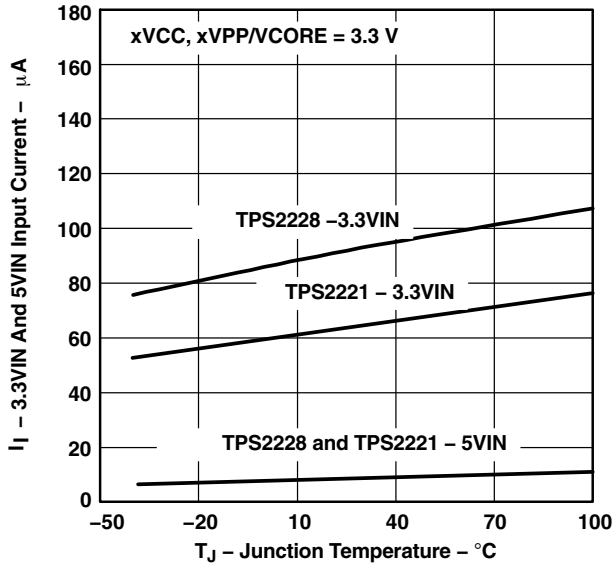

Figure 7

3.3VIN AND 5VIN INPUT CURRENT
vs
JUNCTION TEMPERATURE

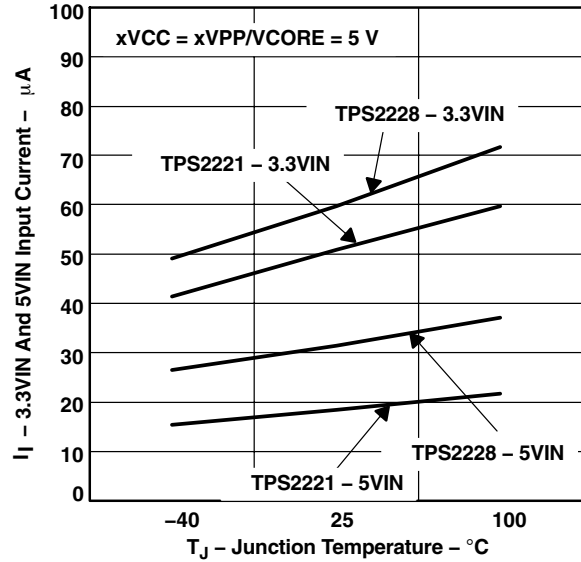

Figure 8

1.8VIN INPUT CURRENT
vs
JUNCTION TEMPERATURE

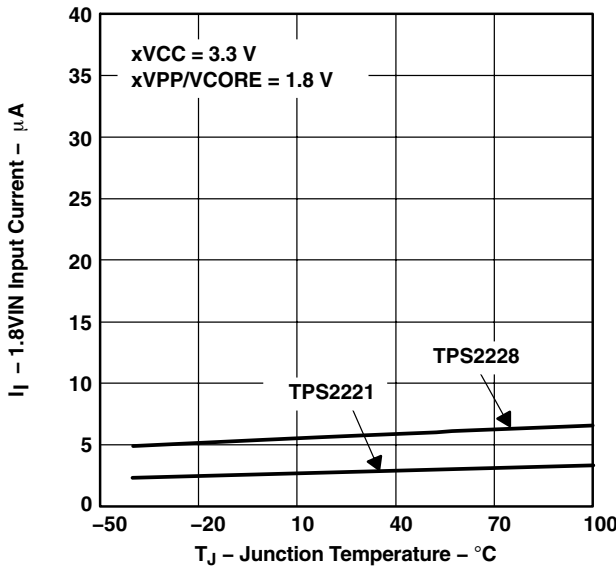

Figure 9

STATIC DRAIN-SOURCE ON-STATE RESISTANCE
(3.3VIN TO xVCC SWITCH)
vs
JUNCTION TEMPERATURE

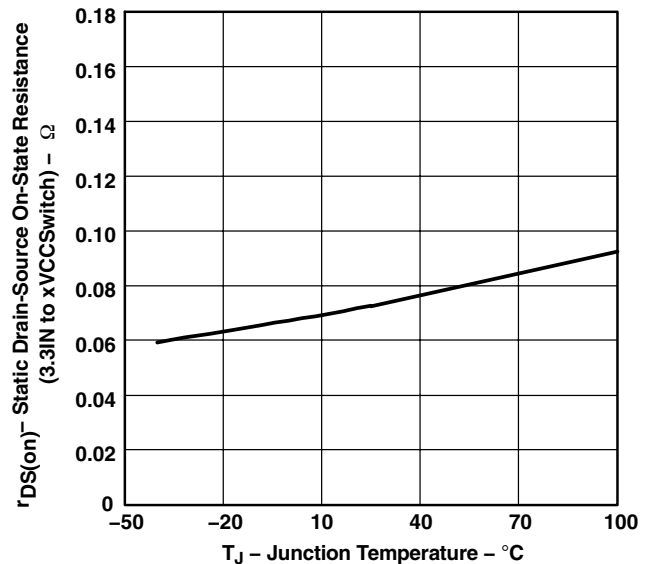

Figure 10

TPS2228
TPS2221

SLVS419C – MAY 2002 REVISED DECEMBER 2008

PARAMETER MEASUREMENT INFORMATION

**STATIC DRAIN-SOURCE ON-STATE RESISTANCE
(5VIN TO xVCC SWITCH)
vs
JUNCTION TEMPERATURE**

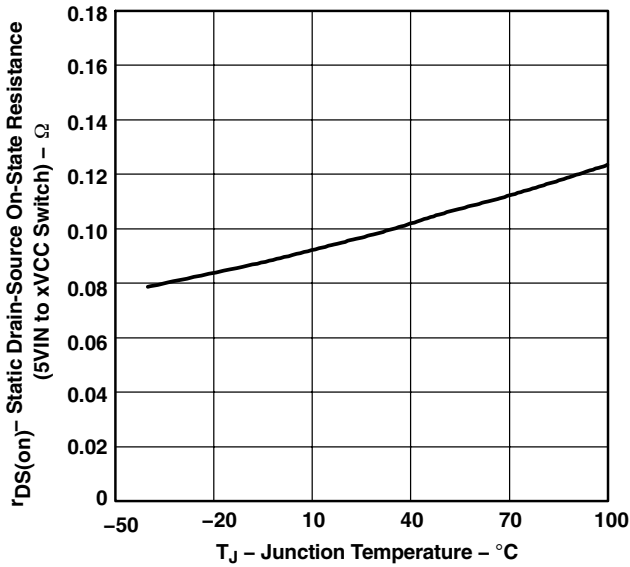

Figure 11

**STATIC DRAIN-SOURCE ON-STATE RESISTANCE
(3.3VIN TO xVPP/VCORE SWITCH)
vs
JUNCTION TEMPERATURE**

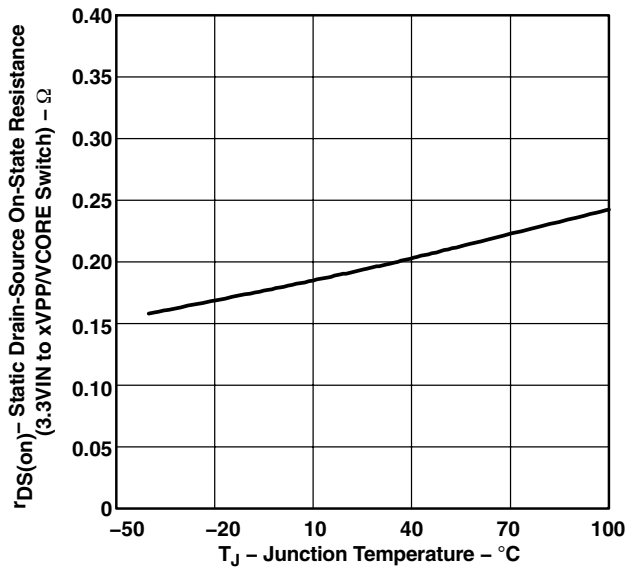

Figure 12

**STATIC DRAIN-SOURCE ON-STATE RESISTANCE
(5VIN TO xVPP/VCORE SWITCH)
vs
JUNCTION TEMPERATURE**

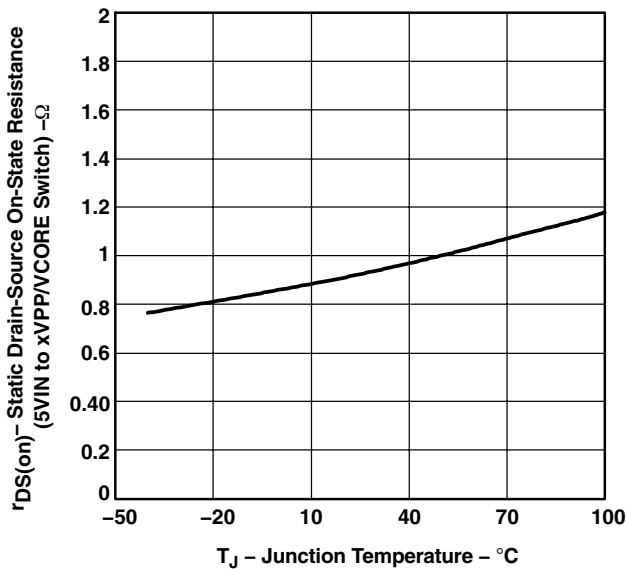

Figure 13

**STATIC DRAIN-SOURCE ON-STATE RESISTANCE
(1.8VIN TO xVPP/VCORE SWITCH)
vs
JUNCTION TEMPERATURE**

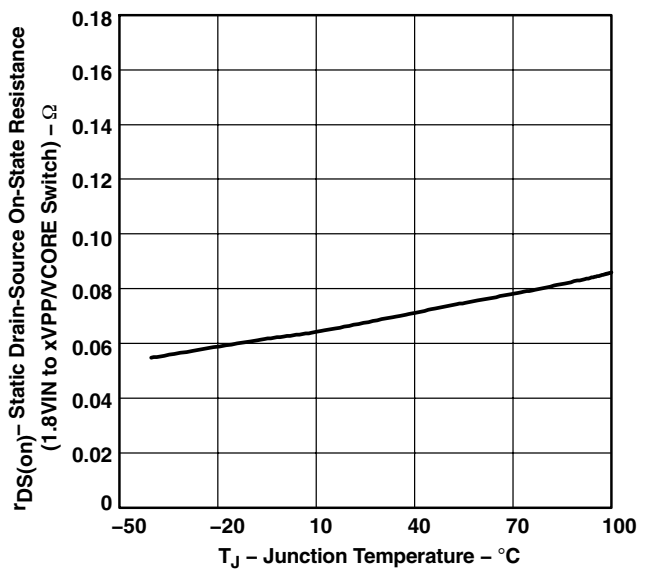

Figure 14

PARAMETER MEASUREMENT INFORMATION

**SHORT-CIRCUIT CURRENT LIMIT
(3.3VIN TO xVCC)
vs
JUNCTION TEMPERATURE**

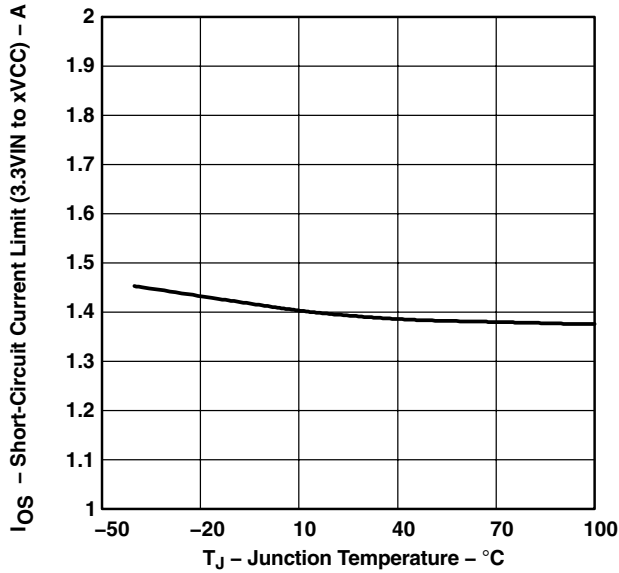

Figure 15

**SHORT-CIRCUIT CURRENT LIMIT
(5VIN TO xVCC)
vs
JUNCTION TEMPERATURE**

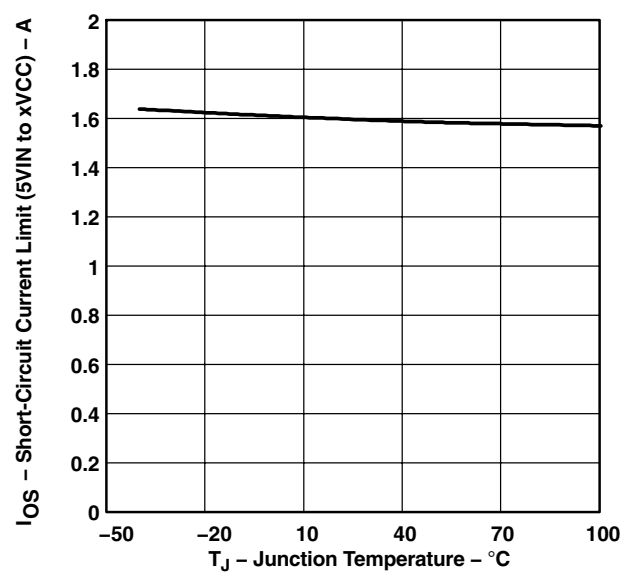

Figure 16

**SHORT-CIRCUIT CURRENT LIMIT
(3.3VIN TO xVPP/VCORE)
vs
JUNCTION TEMPERATURE**

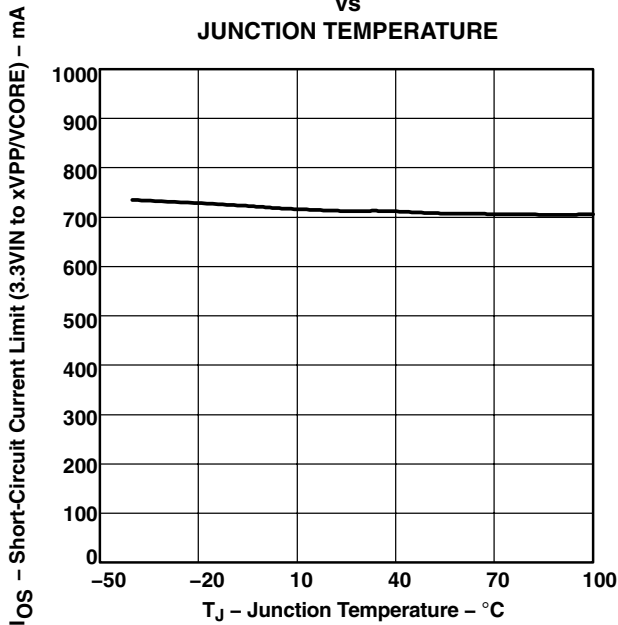

Figure 17

**SHORT-CIRCUIT CURRENT LIMIT
(5VIN TO xVPP/VCORE)
vs
JUNCTION TEMPERATURE**

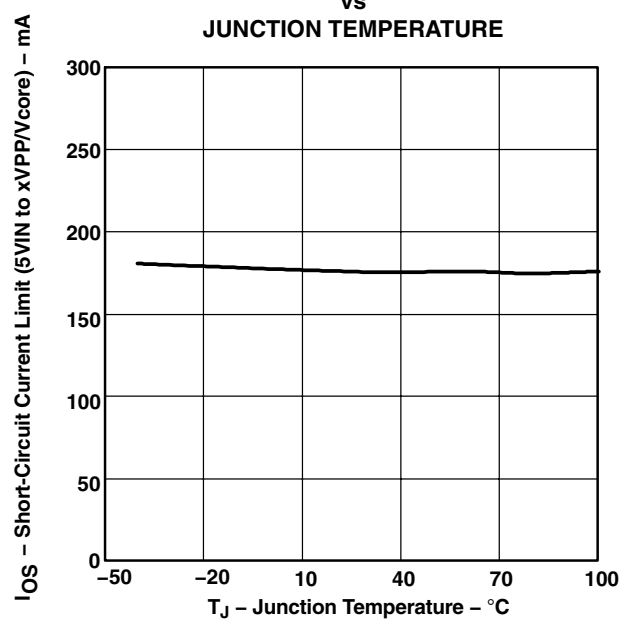
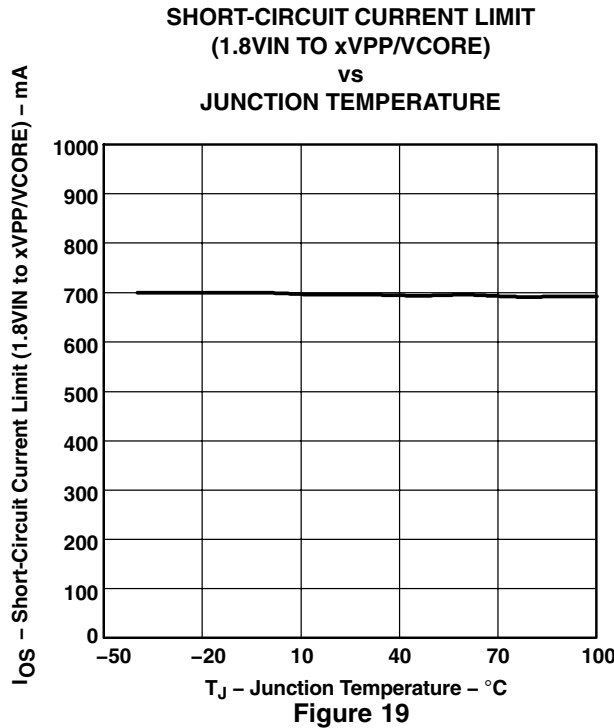

Figure 18

TPS2228
TPS2221

SLVS419C – MAY 2002 REVISED DECEMBER 2008

PARAMETER MEASUREMENT INFORMATION



PIN ASSIGNMENTS

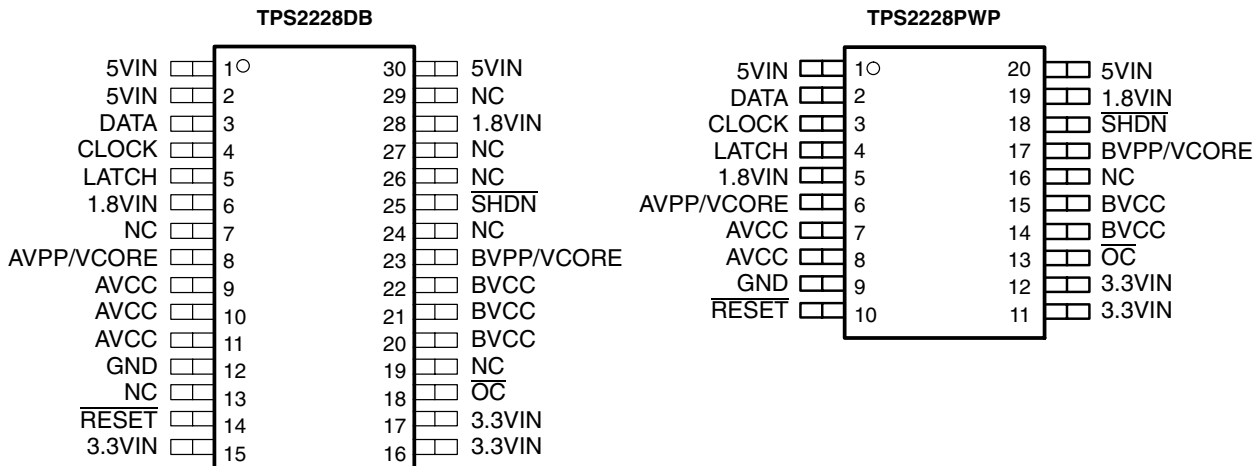

NC – No internal connection

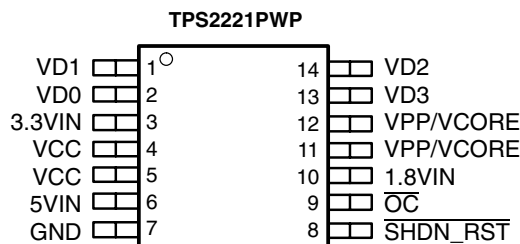

PARAMETER MEASUREMENT INFORMATION

Terminal Functions (Dual-Serial)

TERMINAL			I/O	DESCRIPTION
NAME	NO.			
	2228 (DB-30)	2228 (PWP-20)		
1.8VIN	6, 28	5, 19	I	1.8-V input for card power (xVPP/VCORE). Pins 6 and 28 must be connected together externally.
3.3VIN	15, 16, 17	11, 12	I	3.3-V input for card power (xVCC and xVPP/Vcore) and chip power (3.3VIN must be connected to a voltage source for the device to operate)
5VIN	1, 2, 30	1, 20	I	5-V input for card power (xVCC and xVPP/Vcore)
AVCC	9, 10, 11	7, 8	O	Switched output that delivers 0 V, 3.3 V, 5 V, or high impedance to card
AVPP/VCORE	8	6	O	Switched output that delivers 0 V, 1.8 V, 3.3 V, 5 V, or high impedance to card
BVCC	20, 21, 22	14, 15	O	Switched output that delivers 0 V, 3.3 V, 5 V, or high impedance to card
BVPP/VCORE	23	17	O	Switched output that delivers 0 V, 1.8 V, 3.3 V, 5 V, or high impedance to card
CLOCK	4	3	I	Logic-level clock for serial data word
DATA	3	2	I	Logic-level serial data word
GND	12	9		Ground
LATCH	5	4	I	Logic-level latch for serial data word, an internal pulldown is provided
NC	7, 13, 19, 24, 26, 27, 29	16		No internal connection
OC	18	13	O	Open-drain output that is asserted low when an overcurrent condition exists.
RESET	14	10	I	Logic-level RESET input. Asynchronous command active low. An internal pullup is provided. When active, all line switches are off and all the output discharge switches are on.
SHDN	25	18	I	Hi-Z (open) all switches. Identical function to serial shutdown with D8=0. Asynchronous command active low. An internal pullup is provided.

Terminal Functions (Single – Parallel)

TERMINAL		I/O	DESCRIPTION
NAME	NO. 2221 (PWP-14)		
1.8VIN	10	I	1.8-V input for card power (VPP/VCORE)
3.3VIN	3	I	3.3-V input for card power (VCC and VPP/Vcore) and chip power (3.3VIN must be connected to a voltage source for the device to operate)
5VIN	6	I	5-V input for card power (VCC and VPP/Vcore)
GND	7		Ground
OC	9	O	Open-drain output that is asserted low when an overcurrent condition exists.
SHDN_RST	8	I	Hi-Z (open) all switches. Identical function to serial shutdown mode by parallel data VD (3:0). Asynchronous command active low. An internal pullup is provided.
VCC	4, 5	O	Switched output that delivers 0 V, 3.3 V, 5 V, or high impedance to card
VD0	2	I	Parallel control signal 0 (see Table 2. TPS2221 Control Logic)
VD1	1	I	Parallel control signal 1 (see Table 2. TPS2221 Control Logic)
VD2	14	I	Parallel control signal 2 (see Table 2. TPS2221 Control Logic)
VD3	13	I	Parallel control signal 3 (see Table 2. TPS2221 Control Logic)
VPP/VCORE	11, 12	O	Switched output that delivers 0 V, 1.8 V, 3.3 V, 5 V, or high impedance to card

TPS2228
TPS2221

SLVS419C – MAY 2002 REVISED DECEMBER 2008

FUNCTIONAL BLOCK DIAGRAM

DUAL WITH SERIAL INTERFACE

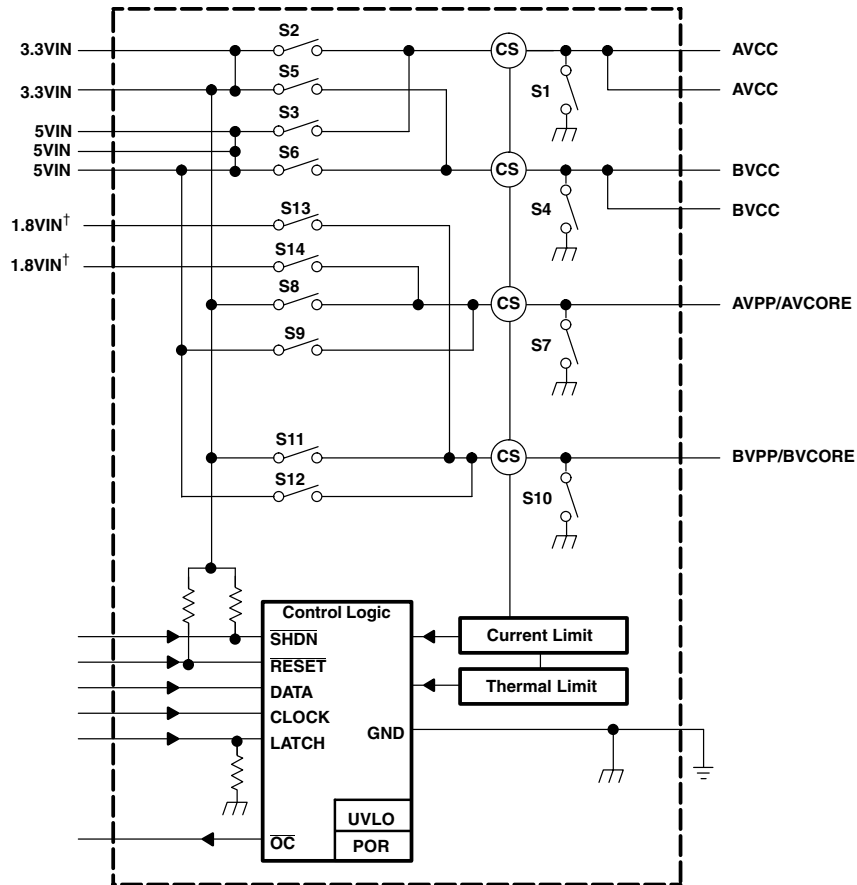

† The two 1.8VIN pins must be connected together externally

FUNCTIONAL BLOCK DIAGRAM

SINGLE WITH PARALLEL INTERFACE

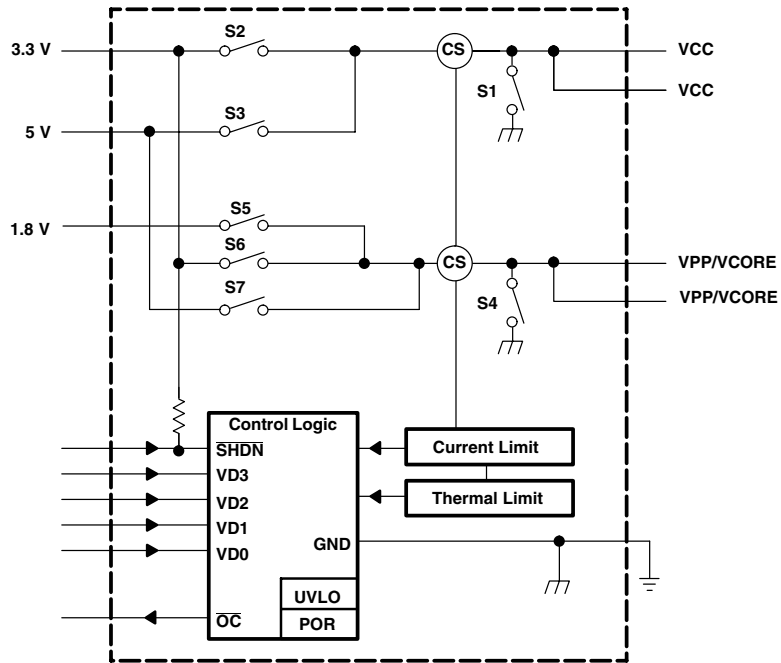

TPS2228 TPS2221

SLVS419A – MAY 2002 REVISED SEPTEMBER 2002

APPLICATION INFORMATION

OVERVIEW

PC cards were initially introduced as a means to add EEPROM (flash memory) to portable computers with limited onboard memory. The idea of add-in cards quickly took hold; modems, wireless LANs, GPS systems, multimedia, and hard-disk versions were soon available. As the number of PC card applications grew, the engineering community quickly recognized the need for a standard to ensure compatibility across platforms. As a result, the PCMCIA (Personal Computer Memory Card International Association) was established, comprised of members from leading computer, software, PC card, and semiconductor manufacturers. One key goal was to realize the *plug-and-play* concept, so that cards and hosts from different vendors could communicate with one another transparently.

PC CARD POWER SPECIFICATION

The current PC card standard set forth by the PCMCIA committee states that power is to be transferred between the host and the card through eight of the PC card connector's 68 terminals. This power interface consists of two V_{CC} , two V_{PP}/V_{CORE} , and four ground terminals. Multiple power and ground terminals minimize connector-terminal and line resistance. The two V_{pp}/V_{core} terminals were originally specified as separate signals, but the host is no longer required to provide separate programmable voltages on each pin. Primary power for the card is supplied through the V_{CC} terminals; flash-memory programming and erase voltage is supplied through the V_{PP}/V_{CORE} terminals. The V_{PP}/V_{CORE} terminals are also intended to be used as a supplemental source of power, such as a core voltage for integrated circuits.

OVERCURRENT AND OVER TEMPERATURE PROTECTION

PC cards are inherently subject to damage caused by mishandling. Host systems require protection against short-circuited cards that could lead to power supply or PCB trace damage. Even systems sufficiently robust to withstand a short circuit would still undergo rapid battery discharge into the damaged PC card, resulting in the rather sudden and unacceptable loss of system power. The TPS2228/2221 power interface switch is designed to respond quickly to an overcurrent condition to protect the system. During an overcurrent event, the current limit circuit of the TPS2228/2221 generates an internal error signal that linearly limits the output current of the affected output. The propagation delay associated with activating the current-limit circuit has an effect on the amount of current initially delivered to the output. During this time, the

input voltage to the switch may droop a small amount. The amount of voltage droop is system dependent. Power supply bulk capacitors play an important role in minimizing this voltage droop.

Overcurrent sensing is applied to each output separately. As a result, only the affected output is current-limited during an overcurrent event. The TPS2228/2221 also has an overcurrent status output (\overline{OC}) that is asserted low to provide feedback that an overcurrent condition has occurred.

The TPS2228/2221 has two thermal shutdown circuits. The higher thermal shutdown circuit protects the device from a high junction temperature condition. In the event that the junction temperature exceeds a minimum of 155°C, the higher thermal shutdown circuit turns off all switches to protect the device. Normal switch operation resumes when the junction temperature cools down approximately 10°C.

In the event of an overcurrent condition, the lower thermal shutdown circuit activates when the junction temperature exceeds a minimum of 120°C. On the TPS2221, this lower thermal shutdown circuit disables both the V_{CC} and the V_{PP}/V_{CORE} switches once the junction temperature exceeds the lower thermal trip point. On the TPS2228, only the channel in overcurrent (either AV_{CC} and AV_{PP}/V_{CORE} , or BV_{CC} and BV_{PP}/V_{CORE}) is disabled. For both the TPS2221 and the TPS2228, normal operation of the switches resumes once the junction temperature cools down approximately 10°C. This cycle continues until the overcurrent condition is removed.

VOLTAGE TRANSITIONING REQUIREMENT

PC cards, like portables, are migrating from 5 V to 3.3 V and even 1.8 V to minimize power consumption, optimize board space, and increase logic speeds. The TPS2228/2221 power interface switch is designed to meet all combinations of power delivery as currently defined in the PC card standard. The latest protocol accommodates mixed 3.3 V/ 5 V systems by first powering the card with 5 V, then polling it to determine if it is compatible with 3.3-V power. The PC card standard requires that the capacitors on 3.3-V compatible cards be discharged to below 0.8 V before applying 3.3 V power. This ensures that sensitive 3.3-V circuitry is not subjected to any residual 5-V charge and functions as a power reset. The PC card standard requires that V_{CC} be discharged within 100 ms. PC card resistance can not be relied on to provide a discharge path for voltages stored on PC card capacitance because of possible high-impedance isolation by power-management schemes. The TPS2228/2221 power interface switch includes discharge transistors on all V_{CC} and V_{PP}/V_{CORE} outputs to meet the specification requirement.

SHUTDOWN MODE

In the shutdown mode, each of the V_{CC} and V_{PP}/V_{CORE} outputs is forced to a high-impedance state (Hi-Z). In this mode, the chip quiescent current is reduced to conserve battery power.

POWER SUPPLY CONSIDERATIONS

The TPS2228/2221 power interface switch has multiple pins for each of its power inputs and for the switched V_{CC} outputs. The two 1.8VIN pins must be connected together externally. It is recommended that all input and output power pins be parallel connected for optimum operation.

To increase the noise immunity of the TPS2228/2221 power interface switch, the power supply inputs should have a minimum of 1 μ F electrolytic or tantalum bypass capacitor connected in parallel with a 0.047 μ F to 0.1 μ F ceramic capacitor. It is strongly recommended that the switched outputs be bypassed with a 0.1 μ F or larger ceramic capacitor. Doing so improves the immunity of the TPS2228/2221 power interface switch to electrostatic discharge (ESD). Care should be taken to minimize the inductance of PCB traces between the TPS2228/2221 power interface switch and the load.

RESET

To ensure that cards are in a known state after power brownouts or system initialization, the PC cards should be reset at the same time via the host, by applying low impedance paths from V_{CC} and V_{PP}/V_{CORE} terminals to ground. A low-impedance output state allows discharging of residual voltage remaining on PC card filter capacitance, permitting the system (host and PC cards) to be powered up concurrently. The active low $\overline{\text{RESET}}$ input will program all outputs to 0 V. The TPS2228 power interface switch remains in the low-impedance output state until the signal is deasserted and new data is received. For the TPS2228, the input serial data cannot be latched during reset mode.

CALCULATING JUNCTION TEMPERATURE

The switch resistance, $r_{DS(on)}$, is dependent on the junction temperature, T_J , of the die. The junction temperature is dependent on both $r_{DS(on)}$ and the current through the switch. To calculate T_J , first find $r_{DS(on)}$ from Figures 10 through 14 using an initial temperature estimate about 50°C above ambient. Then calculate the power dissipation for each switch, using the formula:

$$P_D = r_{DS(on)} \times I^2$$

Next, sum the power dissipation and calculate the junction temperature:

$$T_J = (\sum P_D \times R_{\theta JA}) + T_A$$

Where $R_{\theta JA}$ is the inverse of the derating factor in the dissipation rating table.

Compare the calculated junction temperature with the initial temperature estimate. If the temperatures are not within a few degrees of each other, recalculate using the calculated temperature as the initial estimate.

LOGIC INPUTS AND OUTPUTS

For the TPS2228, the serial interface consists of DATA, CLOCK, and LATCH signals. The data is clocked in on the positive leading edge of the clock (see Figure 2). The 11-bit (D0–D10) serial data word is loaded during the positive edge of the latch signal. The latch signal should occur before the next positive leading edge of the clock.

The serial interface of the TPS2228 power interface switch is designed to be compatible with serial-interface PCMCIA controllers and current PCMCIA and Japan Electronic Industry Development Association (JEIDA) standards.

For the TPS2221, the parallel interface consists of four bits (D3:D0). These four bits must be driven continuously to select the desired voltage outputs based on the input bit pattern. During power up, these inputs can be connected to an external pulldown resistor to ensure that the outputs are at zero volts, especially if the device driving these inputs is in a high impedance state while initializing.

An overcurrent output ($\overline{\text{OC}}$) is provided to indicate an overcurrent or over-temperature condition in any of the V_{CC} and V_{PP}/V_{CORE} outputs as previously discussed.

ESD PROTECTION

All TPS2228/2221 power interface switch inputs and outputs incorporate ESD-protection circuitry designed to withstand a 2-kV human-body-model discharge as defined in MIL-STD-883C, Method 3015. The V_{CC} and V_{PP}/V_{CORE} outputs can be exposed to potentially higher discharges from the external environment through the PC card connector. Bypassing the outputs with 0.1- μ F capacitors protects the devices from discharges up to 10 kV.

TPS2228
TPS2221

SLVS419A – MAY 2002 REVISED SEPTEMBER 2002

Table 1. TPS2228 Power Interface Switch Control Logic

TPS2228 Serial Interface									
xVPP/VCORE									
D8(SHDN)	AVPP/VCORE CONTROL SIGNALS			OUTPUT V_AVPP/ VCORE	BVPP/VCORE CONTROL SIGNALS				OUTPUT V_BVPP/ VCORE
	D0	D1	D9		D8(SHDN)	D4	D5	D10	
1	0	0	X	0 V	1	0	0	X	0 V
1	0	1	0	3.3 V	1	0	1	0	3.3 V
1	0	1	1	5 V	1	0	1	1	5 V
1	1	0	X	Hi-Z	1	1	0	X	Hi-Z
1	1	1	0	1.8 V	1	1	1	0	1.8 V
1	1	1	1	1.8 V	1	1	1	1	1.8 V
0	X	X	X	Hi-Z	0	X	X	X	Hi-Z

xVCC							
D8(SHDN)	AVCC CONTROL SIGNALS		OUTPUT V_AVCC	BVCC CONTROL SIGNALS			OUTPUT V_BVCC
	D3	D2		D8(SHDN)	D6	D7	
1	0	0	0 V	1	0	0	0 V
1	0	1	3.3 V	1	0	1	3.3 V
1	1	0	5 V	1	1	0	5 V
1	1	1	0 V	1	1	1	0 V
0	X	X	Hi-Z	0	X	X	Hi-Z

Table 2. TPS2221 Control Logic

TPAS2221 SINGLES					
D0	D1	D2	D3	VCC	VPP/CORE
0	0	0	0	0 V	0 V
0	0	0	1	Hi-Z	Hi-Z
0	0	1	0	Hi-Z	Hi-Z
0	0	1	1	Hi-Z	Hi-Z
0	1	0	0	3.3 V	0 V
0	1	0	1	3.3 V	3.3 V
0	1	1	0	3.3 V	5 V
0	1	1	1	3.3 V	1.8 V
1	0	0	0	5 V	0 V
1	0	0	1	5 V	3.3 V
1	0	1	0	5 V	5 V
1	0	1	1	5 V	1.8 V
1	1	0	0	Hi-Z	Hi-Z
1	1	0	1	3.3 V	Hi-Z
1	1	1	0	5 V	Hi-Z
1	1	1	1	Hi-Z	Hi-Z

NOTE: VCC = VPP/VCORE = Hi-Z indicates the device is in shutdown mode.

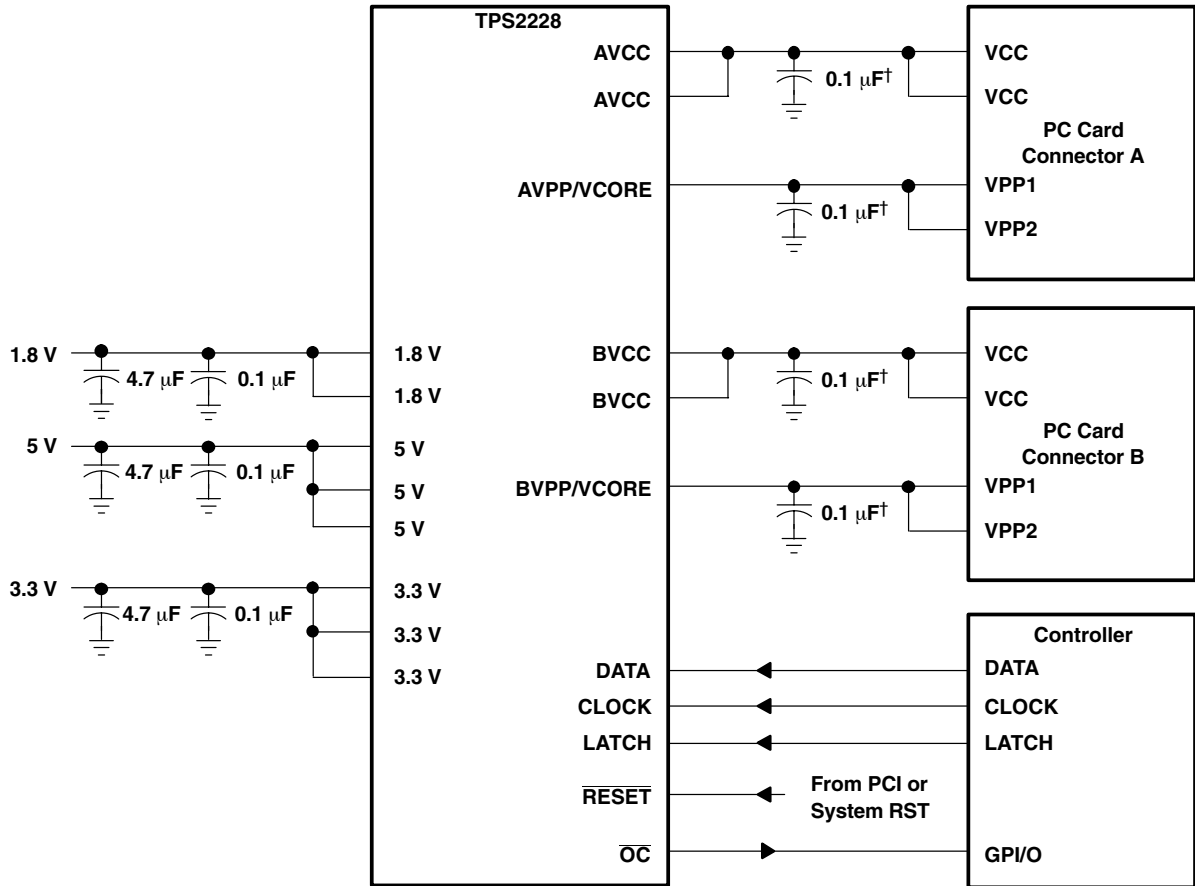

† Maximum recommended output capacitance for xVCC is 150 μF including card capacitance, and for xVPP is 10 μF, without \overline{OC} glitch when switches are powered on.

Figure 20. TPS2228 Dual Slot Application

TPS2228
TPS2221

SLVS419A – MAY 2002 REVISED SEPTEMBER 2002

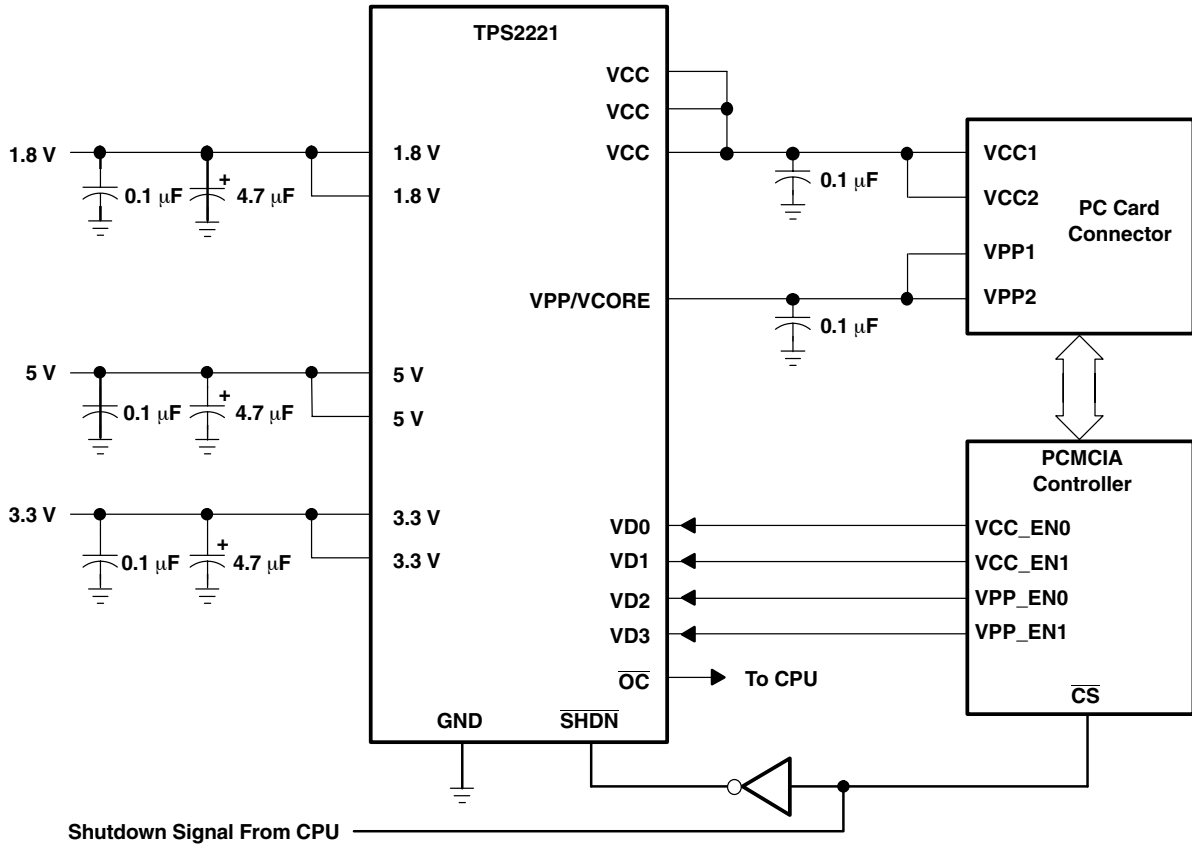

Figure 21. TPS2221 Single Slot Application

PACKAGING INFORMATION

Orderable Device	Status (1)	Package Type	Package Drawing	Pins	Package Qty	Eco Plan (2)	Lead/Ball Finish (6)	MSL Peak Temp (3)	Op Temp (°C)	Device Marking (4/5)	Samples
TPS2221PWP	ACTIVE	HTSSOP	PWP	14	90	Green (RoHS & no Sb/Br)	CU NIPDAU	Level-2-260C-1 YEAR	-40 to 85	TPS2221	Samples
TPS2221PWPG4	ACTIVE	HTSSOP	PWP	14	90	Green (RoHS & no Sb/Br)	CU NIPDAU	Level-2-260C-1 YEAR	-40 to 85	TPS2221	Samples
TPS2221PWPR	ACTIVE	HTSSOP	PWP	14	2000	Green (RoHS & no Sb/Br)	CU NIPDAU	Level-2-260C-1 YEAR	-40 to 85	TPS2221	Samples
TPS2228DB	ACTIVE	SSOP	DB	30	50	Green (RoHS & no Sb/Br)	CU NIPDAU	Level-1-260C-UNLIM	-40 to 85	TPS2228	Samples
TPS2228DBR	ACTIVE	SSOP	DB	30		Green (RoHS & no Sb/Br)	CU NIPDAU	Level-1-260C-UNLIM	-40 to 85	TPS2228	Samples
TPS2228PWP	ACTIVE	HTSSOP	PWP	20	70	Green (RoHS & no Sb/Br)	CU NIPDAU	Level-2-260C-1 YEAR	-40 to 85	TPS2228	Samples
TPS2228PWPG4	ACTIVE	HTSSOP	PWP	20	70	Green (RoHS & no Sb/Br)	CU NIPDAU	Level-2-260C-1 YEAR	-40 to 85	TPS2228	Samples
TPS2228PWPR	ACTIVE	HTSSOP	PWP	20	2000	Green (RoHS & no Sb/Br)	CU NIPDAU	Level-2-260C-1 YEAR	-40 to 85	TPS2228	Samples

(1) The marketing status values are defined as follows:

ACTIVE: Product device recommended for new designs.

LIFEBUY: TI has announced that the device will be discontinued, and a lifetime-buy period is in effect.

NRND: Not recommended for new designs. Device is in production to support existing customers, but TI does not recommend using this part in a new design.

PREVIEW: Device has been announced but is not in production. Samples may or may not be available.

OBsolete: TI has discontinued the production of the device.

(2) Eco Plan - The planned eco-friendly classification: Pb-Free (RoHS), Pb-Free (RoHS Exempt), or Green (RoHS & no Sb/Br) - please check <http://www.ti.com/productcontent> for the latest availability information and additional product content details.

TBD: The Pb-Free/Green conversion plan has not been defined.

Pb-Free (RoHS): TI's terms "Lead-Free" or "Pb-Free" mean semiconductor products that are compatible with the current RoHS requirements for all 6 substances, including the requirement that lead not exceed 0.1% by weight in homogeneous materials. Where designed to be soldered at high temperatures, TI Pb-Free products are suitable for use in specified lead-free processes.

Pb-Free (RoHS Exempt): This component has a RoHS exemption for either 1) lead-based flip-chip solder bumps used between the die and package, or 2) lead-based die adhesive used between the die and leadframe. The component is otherwise considered Pb-Free (RoHS compatible) as defined above.

Green (RoHS & no Sb/Br): TI defines "Green" to mean Pb-Free (RoHS compatible), and free of Bromine (Br) and Antimony (Sb) based flame retardants (Br or Sb do not exceed 0.1% by weight in homogeneous material)

(3) MSL, Peak Temp. - The Moisture Sensitivity Level rating according to the JEDEC industry standard classifications, and peak solder temperature.



⁽⁴⁾ There may be additional marking, which relates to the logo, the lot trace code information, or the environmental category on the device.

⁽⁵⁾ Multiple Device Markings will be inside parentheses. Only one Device Marking contained in parentheses and separated by a "-" will appear on a device. If a line is indented then it is a continuation of the previous line and the two combined represent the entire Device Marking for that device.

⁽⁶⁾ Lead/Ball Finish - Orderable Devices may have multiple material finish options. Finish options are separated by a vertical ruled line. Lead/Ball Finish values may wrap to two lines if the finish value exceeds the maximum column width.

Important Information and Disclaimer: The information provided on this page represents TI's knowledge and belief as of the date that it is provided. TI bases its knowledge and belief on information provided by third parties, and makes no representation or warranty as to the accuracy of such information. Efforts are underway to better integrate information from third parties. TI has taken and continues to take reasonable steps to provide representative and accurate information but may not have conducted destructive testing or chemical analysis on incoming materials and chemicals. TI and TI suppliers consider certain information to be proprietary, and thus CAS numbers and other limited information may not be available for release.

In no event shall TI's liability arising out of such information exceed the total purchase price of the TI part(s) at issue in this document sold by TI to Customer on an annual basis.

TAPE AND REEL INFORMATION

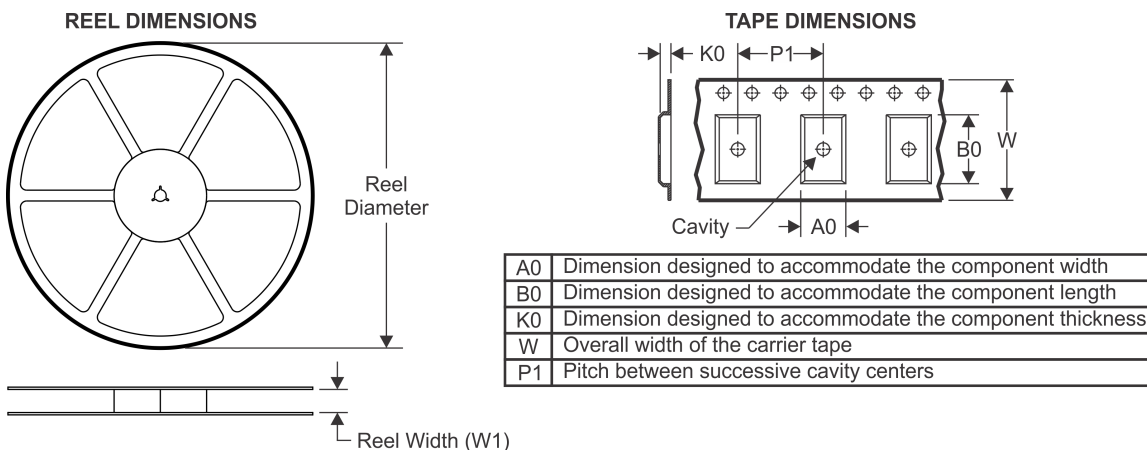

QUADRANT ASSIGNMENTS FOR PIN 1 ORIENTATION IN TAPE

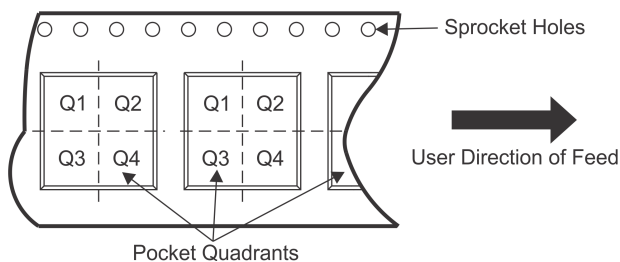

*All dimensions are nominal

Device	Package Type	Package Drawing	Pins	SPQ	Reel Diameter (mm)	Reel Width W1 (mm)	A0 (mm)	B0 (mm)	K0 (mm)	P1 (mm)	W (mm)	Pin1 Quadrant
TPS2221PWPR	HTSSOP	PWP	14	2000	330.0	12.4	6.9	5.6	1.6	8.0	12.0	Q1
TPS2228DBR	SSOP	DB	30	2000	330.0	16.4	8.2	10.5	2.5	12.0	16.0	Q1
TPS2228PWPR	HTSSOP	PWP	20	2000	330.0	16.4	6.95	7.1	1.6	8.0	16.0	Q1

TAPE AND REEL BOX DIMENSIONS

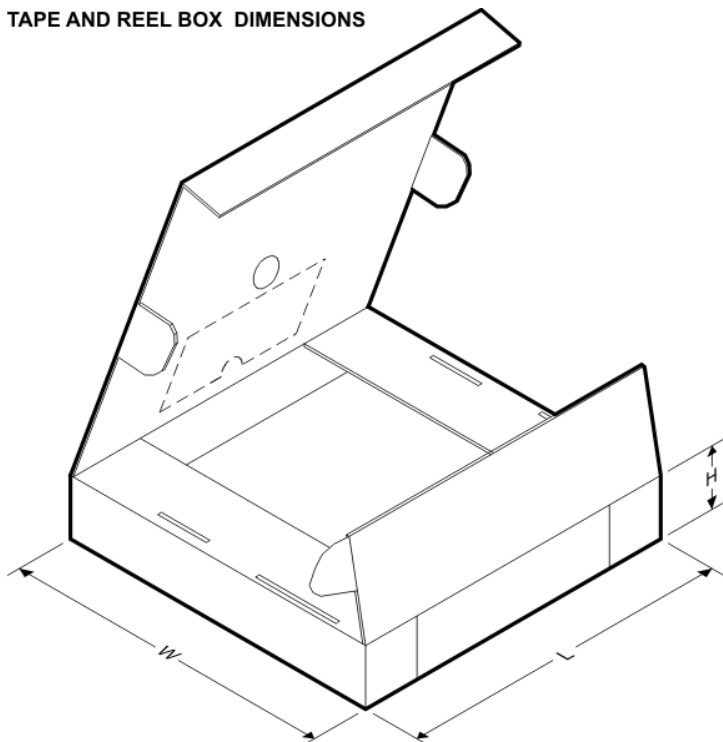

*All dimensions are nominal

Device	Package Type	Package Drawing	Pins	SPQ	Length (mm)	Width (mm)	Height (mm)
TPS2221PWPR	HTSSOP	PWP	14	2000	367.0	367.0	38.0
TPS2228DBR	SSOP	DB	30	2000	367.0	367.0	38.0
TPS2228PWPR	HTSSOP	PWP	20	2000	367.0	367.0	38.0

MECHANICAL DATA

PWP (R-PDSO-G20)

PowerPAD™ PLASTIC SMALL OUTLINE

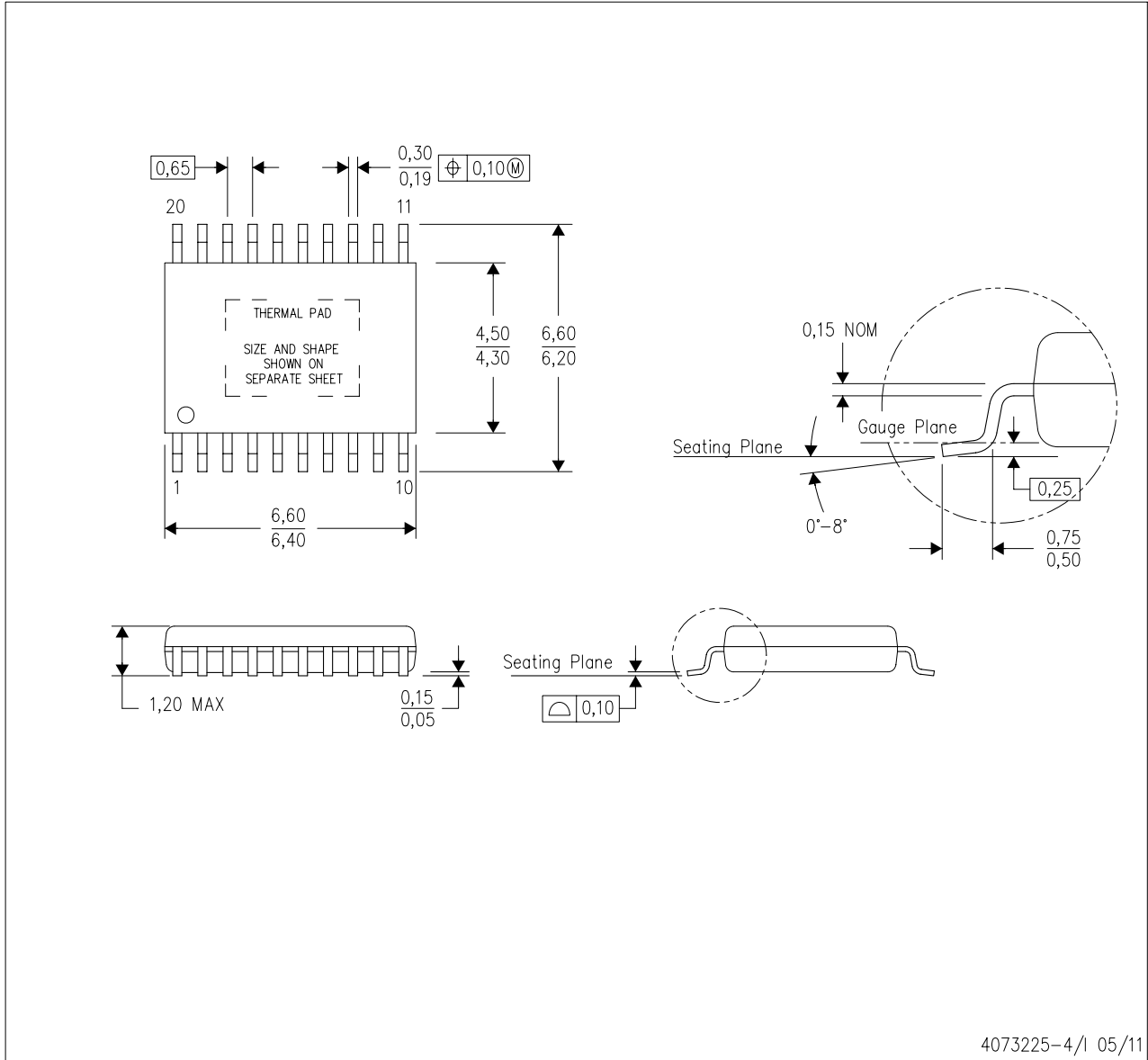

- NOTES:
- All linear dimensions are in millimeters.
 - This drawing is subject to change without notice.
 - Body dimensions do not include mold flash or protrusions. Mold flash and protrusion shall not exceed 0.15 per side.
 - This package is designed to be soldered to a thermal pad on the board. Refer to Technical Brief, PowerPad Thermally Enhanced Package, Texas Instruments Literature No. SLMA002 for information regarding recommended board layout. This document is available at www.ti.com <<http://www.ti.com>>.
 - See the additional figure in the Product Data Sheet for details regarding the exposed thermal pad features and dimensions.
 - Falls within JEDEC MO-153

PowerPAD is a trademark of Texas Instruments.

THERMAL PAD MECHANICAL DATA

PWP (R-PDSO-G20) PowerPAD™ SMALL PLASTIC OUTLINE

THERMAL INFORMATION

This PowerPAD™ package incorporates an exposed thermal pad that is designed to be attached to a printed circuit board (PCB). The thermal pad must be soldered directly to the PCB. After soldering, the PCB can be used as a heatsink. In addition, through the use of thermal vias, the thermal pad can be attached directly to the appropriate copper plane shown in the electrical schematic for the device, or alternatively, can be attached to a special heatsink structure designed into the PCB. This design optimizes the heat transfer from the integrated circuit (IC).

For additional information on the PowerPAD package and how to take advantage of its heat dissipating abilities, refer to Technical Brief, PowerPAD Thermally Enhanced Package, Texas Instruments Literature No. SLMA002 and Application Brief, PowerPAD Made Easy, Texas Instruments Literature No. SLMA004. Both documents are available at www.ti.com.

The exposed thermal pad dimensions for this package are shown in the following illustration.

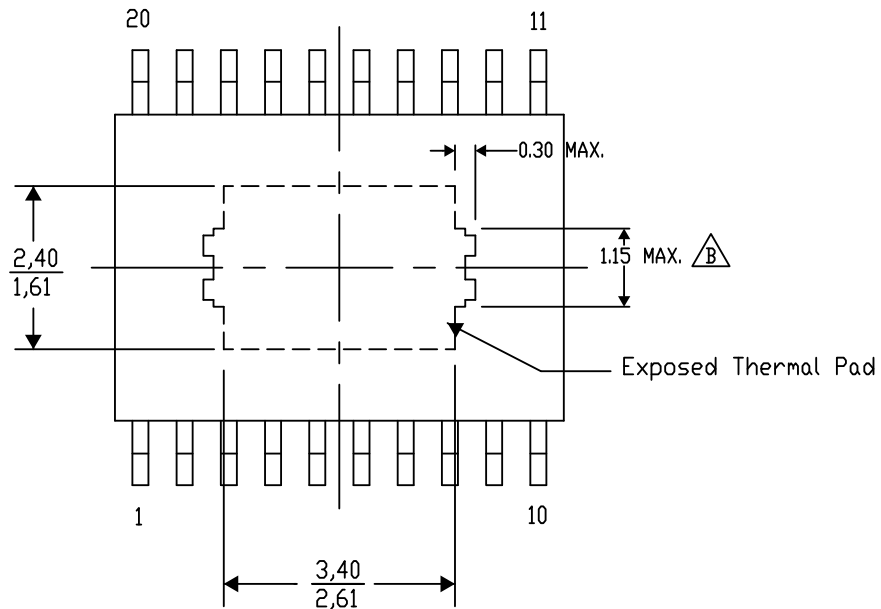

Top View

Exposed Thermal Pad Dimensions

4206332-15/AO 01/16

NOTE: A. All linear dimensions are in millimeters

 Exposed tie strap features may not be present.

PowerPAD is a trademark of Texas Instruments

LAND PATTERN DATA

PWP (R-PDSO-G20)

PowerPAD™ PLASTIC SMALL OUTLINE

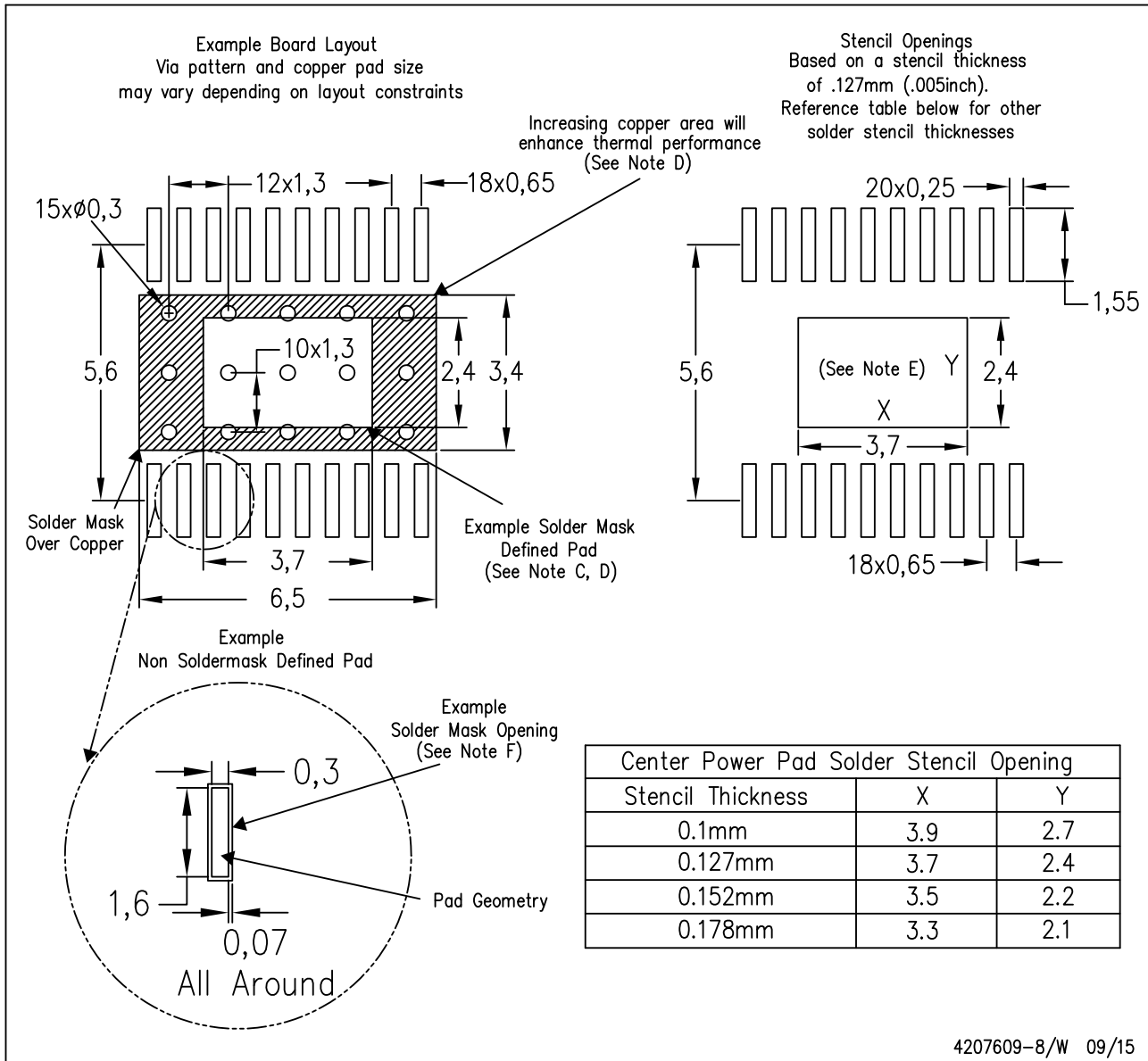

- NOTES:
- A. All linear dimensions are in millimeters.
 - B. This drawing is subject to change without notice.
 - C. Customers should place a note on the circuit board fabrication drawing not to alter the center solder mask defined pad.
 - D. This package is designed to be soldered to a thermal pad on the board. Refer to Technical Brief, PowerPad Thermally Enhanced Package, Texas Instruments Literature No. SLMA002, SLMA004, and also the Product Data Sheets for specific thermal information, via requirements, and recommended board layout. These documents are available at www.ti.com <<http://www.ti.com>>. Publication IPC-7351 is recommended for alternate designs.
 - E. Laser cutting apertures with trapezoidal walls and also rounding corners will offer better paste release. Customers should contact their board assembly site for stencil design recommendations. Example stencil design based on a 50% volumetric metal load solder paste. Refer to IPC-7525 for other stencil recommendations.
 - F. Customers should contact their board fabrication site for solder mask tolerances between and around signal pads.

MECHANICAL DATA

PWP (R-PDSO-G14)

PowerPAD™ PLASTIC SMALL OUTLINE

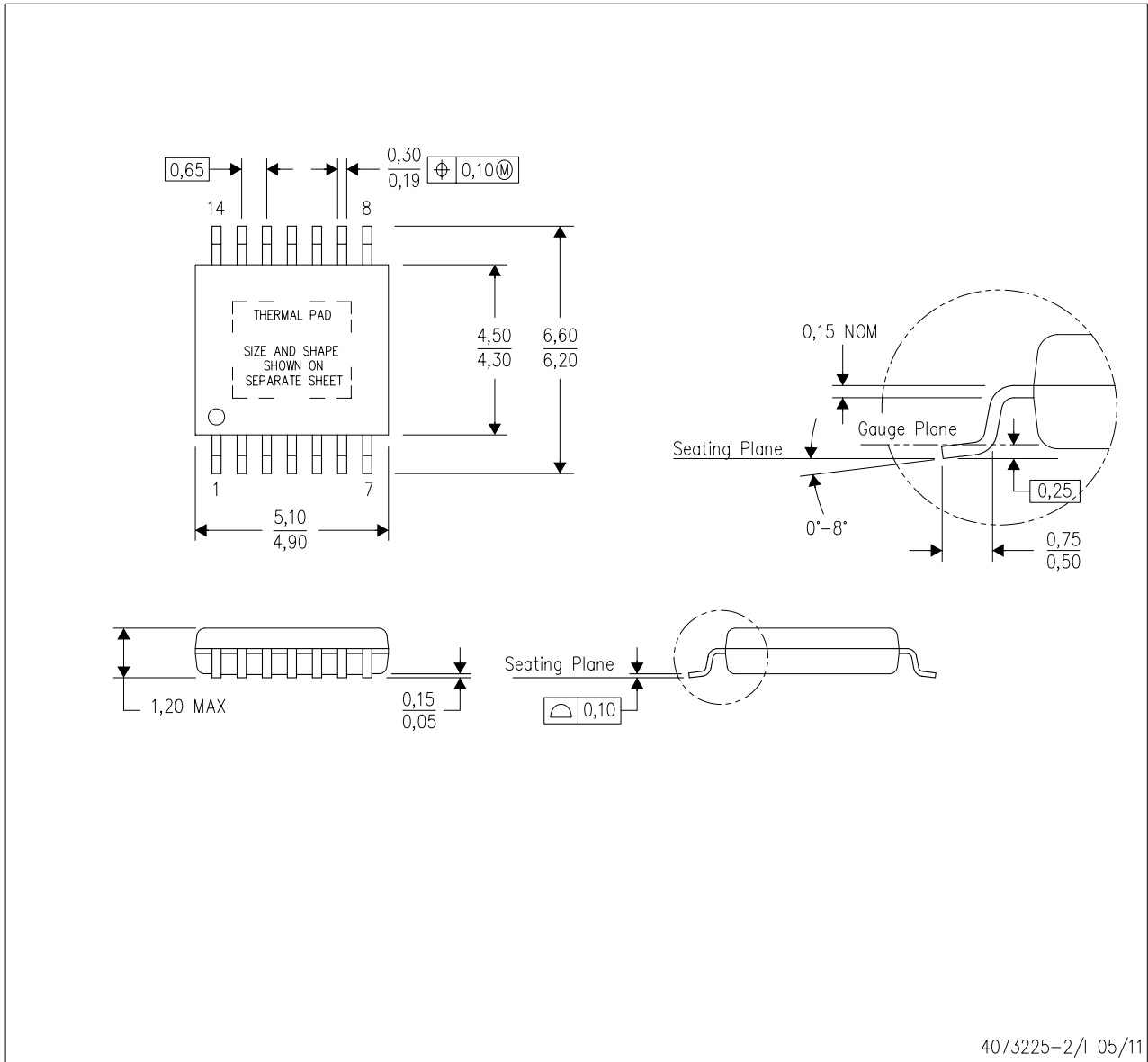

4073225-2/1 05/11

- NOTES:
- A. All linear dimensions are in millimeters.
 - B. This drawing is subject to change without notice.
 - C. Body dimensions do not include mold flash or protrusions. Mold flash and protrusion shall not exceed 0.15 per side.
 - D. This package is designed to be soldered to a thermal pad on the board. Refer to Technical Brief, PowerPad Thermally Enhanced Package, Texas Instruments Literature No. SLMA002 for information regarding recommended board layout. This document is available at www.ti.com <<http://www.ti.com>>.
 - E. See the additional figure in the Product Data Sheet for details regarding the exposed thermal pad features and dimensions.
 - F. Falls within JEDEC MO-153

PowerPAD is a trademark of Texas Instruments.

THERMAL PAD MECHANICAL DATA

PWP (R-PDSO-G14) PowerPAD™ SMALL PLASTIC OUTLINE

THERMAL INFORMATION

This PowerPAD™ package incorporates an exposed thermal pad that is designed to be attached to a printed circuit board (PCB). The thermal pad must be soldered directly to the PCB. After soldering, the PCB can be used as a heatsink. In addition, through the use of thermal vias, the thermal pad can be attached directly to the appropriate copper plane shown in the electrical schematic for the device, or alternatively, can be attached to a special heatsink structure designed into the PCB. This design optimizes the heat transfer from the integrated circuit (IC).

For additional information on the PowerPAD package and how to take advantage of its heat dissipating abilities, refer to Technical Brief, PowerPAD Thermally Enhanced Package, Texas Instruments Literature No. SLMA002 and Application Brief, PowerPAD Made Easy, Texas Instruments Literature No. SLMA004. Both documents are available at www.ti.com.

The exposed thermal pad dimensions for this package are shown in the following illustration.

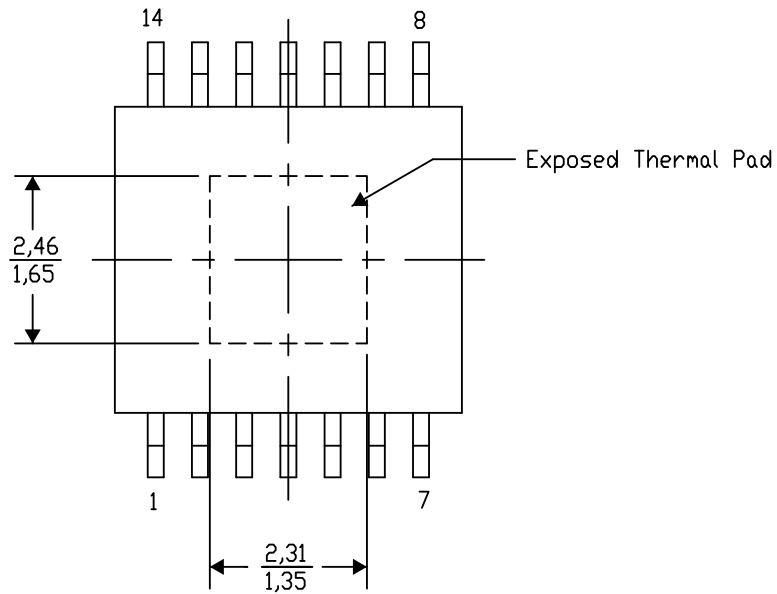

Top View

Exposed Thermal Pad Dimensions

4206332-2/AO 01/16

NOTE: A. All linear dimensions are in millimeters

PowerPAD is a trademark of Texas Instruments

LAND PATTERN DATA

PWP (R-PDSO-G14)

PowerPAD™ PLASTIC SMALL OUTLINE

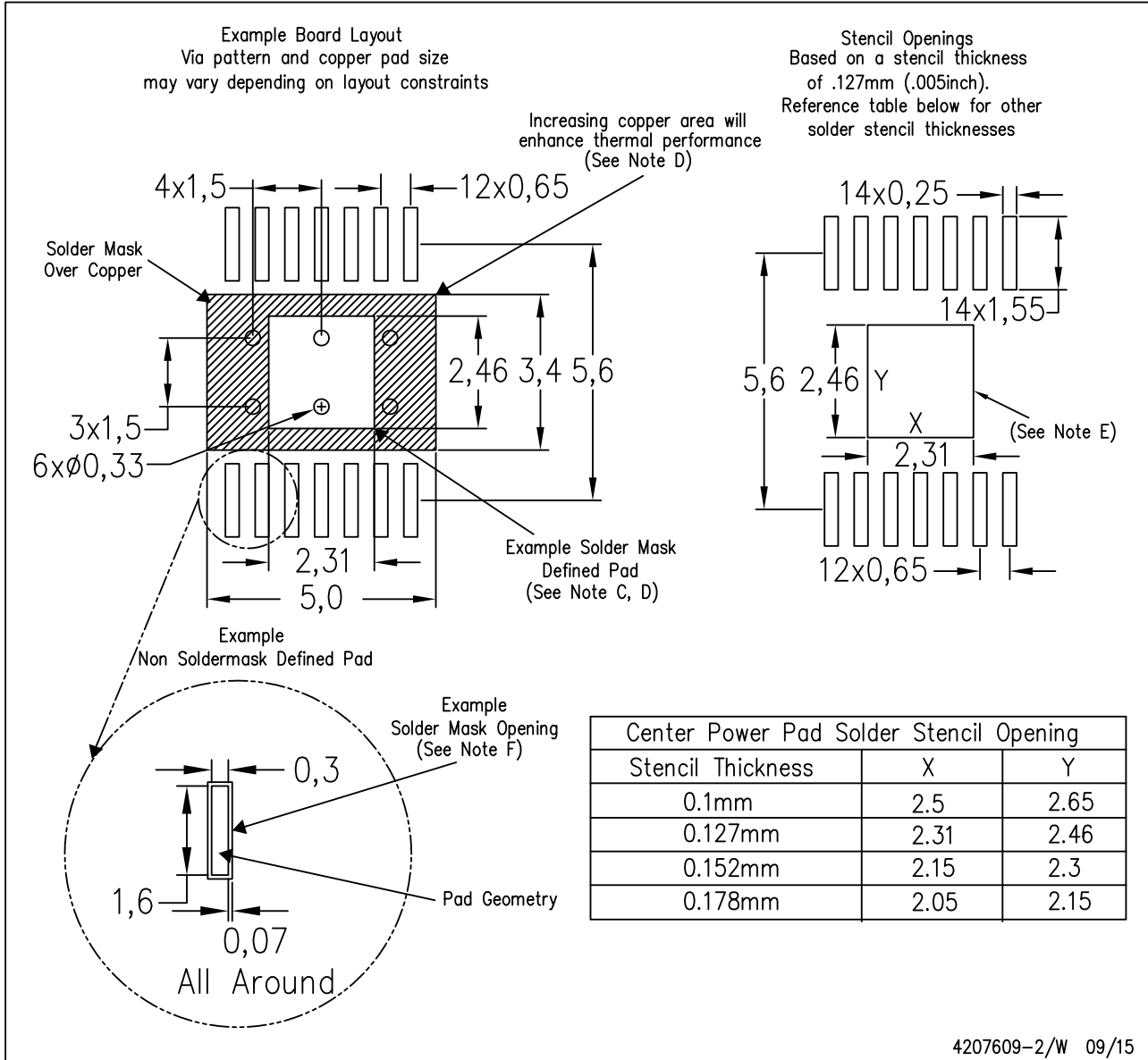

- NOTES:
- A. All linear dimensions are in millimeters.
 - B. This drawing is subject to change without notice.
 - C. Customers should place a note on the circuit board fabrication drawing not to alter the center solder mask defined pad.
 - D. This package is designed to be soldered to a thermal pad on the board. Refer to Technical Brief, PowerPad Thermally Enhanced Package, Texas Instruments Literature No. SLMA002, SLMA004, and also the Product Data Sheets for specific thermal information, via requirements, and recommended board layout. These documents are available at www.ti.com <<http://www.ti.com>>. Publication IPC-7351 is recommended for alternate designs.
 - E. Laser cutting apertures with trapezoidal walls and also rounding corners will offer better paste release. Customers should contact their board assembly site for stencil design recommendations. Example stencil design based on a 50% volumetric metal load solder paste. Refer to IPC-7525 for other stencil recommendations.
 - F. Customers should contact their board fabrication site for solder mask tolerances between and around signal pads.

THERMAL PAD MECHANICAL DATA

PWP (R-PDSO-G14) PowerPAD™ SMALL PLASTIC OUTLINE

THERMAL INFORMATION

This PowerPAD™ package incorporates an exposed thermal pad that is designed to be attached to a printed circuit board (PCB). The thermal pad must be soldered directly to the PCB. After soldering, the PCB can be used as a heatsink. In addition, through the use of thermal vias, the thermal pad can be attached directly to the appropriate copper plane shown in the electrical schematic for the device, or alternatively, can be attached to a special heatsink structure designed into the PCB. This design optimizes the heat transfer from the integrated circuit (IC).

For additional information on the PowerPAD package and how to take advantage of its heat dissipating abilities, refer to Technical Brief, PowerPAD Thermally Enhanced Package, Texas Instruments Literature No. SLMA002 and Application Brief, PowerPAD Made Easy, Texas Instruments Literature No. SLMA004. Both documents are available at www.ti.com.

The exposed thermal pad dimensions for this package are shown in the following illustration.

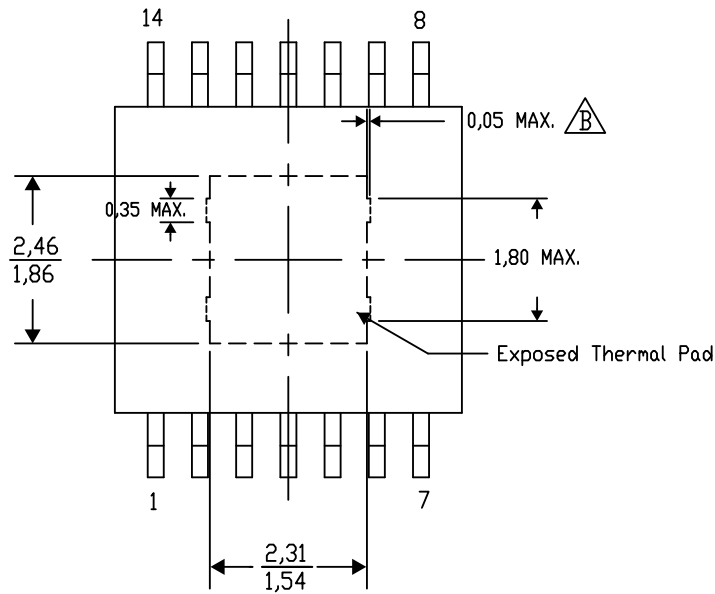

Top View

Exposed Thermal Pad Dimensions

4206332-44/AO 01/16

NOTE: A. All linear dimensions are in millimeters
 ⚠ Exposed tie strap features may not be present.

PowerPAD is a trademark of Texas Instruments

LAND PATTERN DATA

PWP (R-PDSO-G14)

PowerPAD™ PLASTIC SMALL OUTLINE

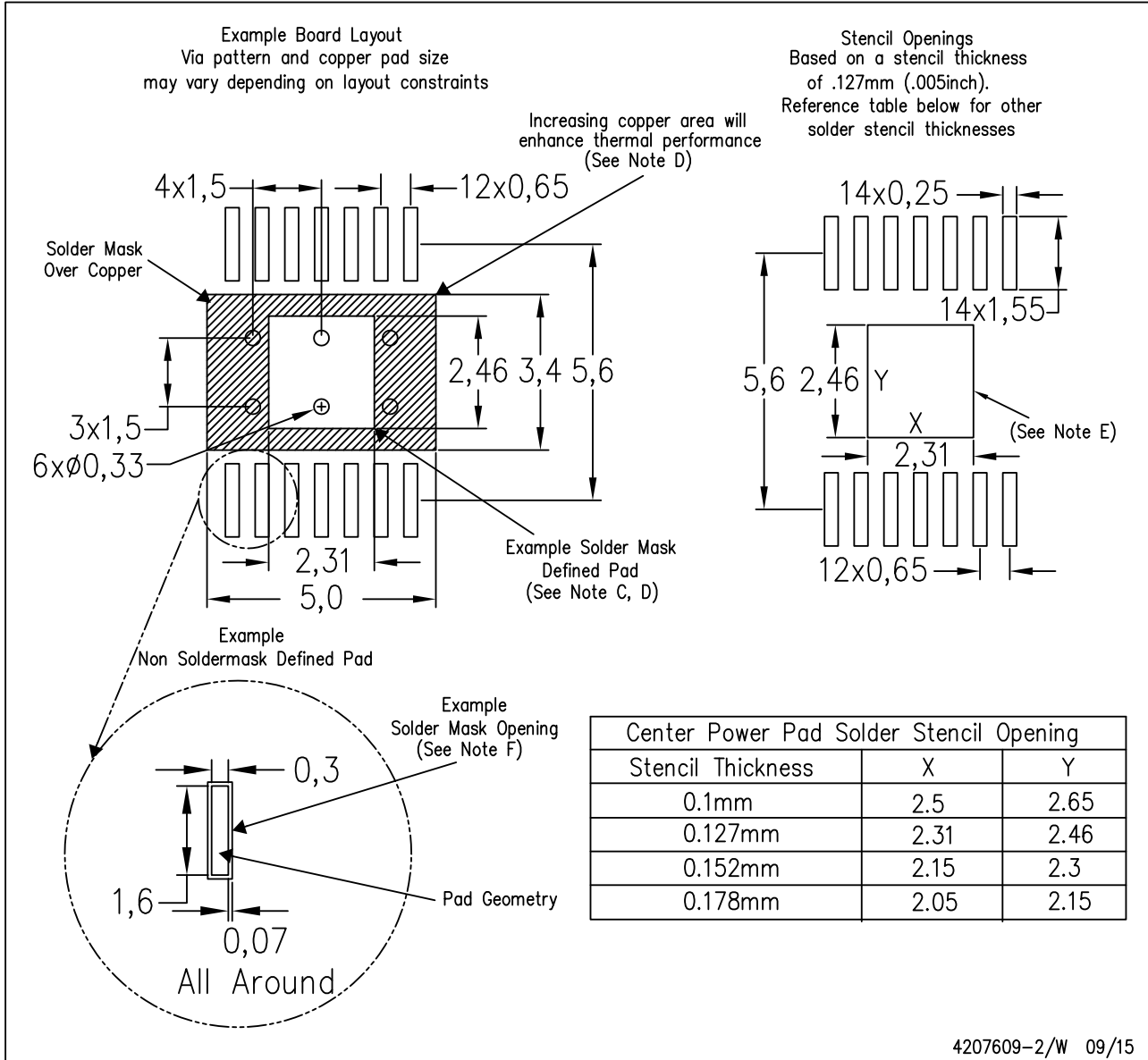

- NOTES:
- All linear dimensions are in millimeters.
 - This drawing is subject to change without notice.
 - Customers should place a note on the circuit board fabrication drawing not to alter the center solder mask defined pad.
 - This package is designed to be soldered to a thermal pad on the board. Refer to Technical Brief, PowerPad Thermally Enhanced Package, Texas Instruments Literature No. SLMA002, SLMA004, and also the Product Data Sheets for specific thermal information, via requirements, and recommended board layout. These documents are available at www.ti.com <<http://www.ti.com>>. Publication IPC-7351 is recommended for alternate designs.
 - Laser cutting apertures with trapezoidal walls and also rounding corners will offer better paste release. Customers should contact their board assembly site for stencil design recommendations. Example stencil design based on a 50% volumetric metal load solder paste. Refer to IPC-7525 for other stencil recommendations.
 - Customers should contact their board fabrication site for solder mask tolerances between and around signal pads.

MSS0002E - JANUARY 1995 - REVISED DECEMBER 2001

DB (R-PDSO-G)**

PLASTIC SMALL-OUTLINE

28 PINS SHOWN

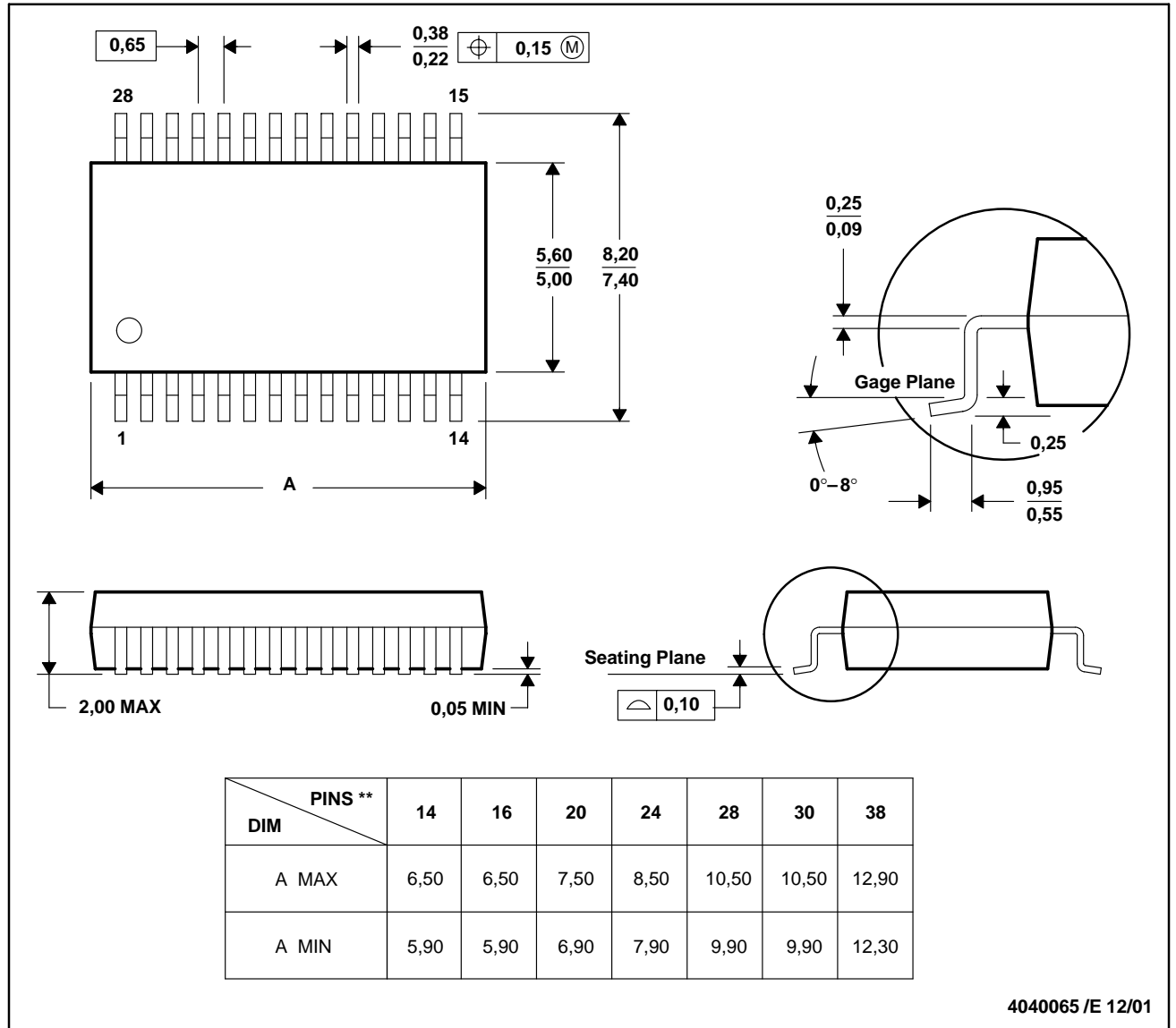

4040065 / E 12/01

- NOTES: A. All linear dimensions are in millimeters.
 B. This drawing is subject to change without notice.
 C. Body dimensions do not include mold flash or protrusion not to exceed 0,15.
 D. Falls within JEDEC MO-150

IMPORTANT NOTICE

Texas Instruments Incorporated and its subsidiaries (TI) reserve the right to make corrections, enhancements, improvements and other changes to its semiconductor products and services per JESD46, latest issue, and to discontinue any product or service per JESD48, latest issue. Buyers should obtain the latest relevant information before placing orders and should verify that such information is current and complete. All semiconductor products (also referred to herein as “components”) are sold subject to TI’s terms and conditions of sale supplied at the time of order acknowledgment.

TI warrants performance of its components to the specifications applicable at the time of sale, in accordance with the warranty in TI’s terms and conditions of sale of semiconductor products. Testing and other quality control techniques are used to the extent TI deems necessary to support this warranty. Except where mandated by applicable law, testing of all parameters of each component is not necessarily performed.

TI assumes no liability for applications assistance or the design of Buyers’ products. Buyers are responsible for their products and applications using TI components. To minimize the risks associated with Buyers’ products and applications, Buyers should provide adequate design and operating safeguards.

TI does not warrant or represent that any license, either express or implied, is granted under any patent right, copyright, mask work right, or other intellectual property right relating to any combination, machine, or process in which TI components or services are used. Information published by TI regarding third-party products or services does not constitute a license to use such products or services or a warranty or endorsement thereof. Use of such information may require a license from a third party under the patents or other intellectual property of the third party, or a license from TI under the patents or other intellectual property of TI.

Reproduction of significant portions of TI information in TI data books or data sheets is permissible only if reproduction is without alteration and is accompanied by all associated warranties, conditions, limitations, and notices. TI is not responsible or liable for such altered documentation. Information of third parties may be subject to additional restrictions.

Resale of TI components or services with statements different from or beyond the parameters stated by TI for that component or service voids all express and any implied warranties for the associated TI component or service and is an unfair and deceptive business practice. TI is not responsible or liable for any such statements.

Buyer acknowledges and agrees that it is solely responsible for compliance with all legal, regulatory and safety-related requirements concerning its products, and any use of TI components in its applications, notwithstanding any applications-related information or support that may be provided by TI. Buyer represents and agrees that it has all the necessary expertise to create and implement safeguards which anticipate dangerous consequences of failures, monitor failures and their consequences, lessen the likelihood of failures that might cause harm and take appropriate remedial actions. Buyer will fully indemnify TI and its representatives against any damages arising out of the use of any TI components in safety-critical applications.

In some cases, TI components may be promoted specifically to facilitate safety-related applications. With such components, TI’s goal is to help enable customers to design and create their own end-product solutions that meet applicable functional safety standards and requirements. Nonetheless, such components are subject to these terms.

No TI components are authorized for use in FDA Class III (or similar life-critical medical equipment) unless authorized officers of the parties have executed a special agreement specifically governing such use.

Only those TI components which TI has specifically designated as military grade or “enhanced plastic” are designed and intended for use in military/aerospace applications or environments. Buyer acknowledges and agrees that any military or aerospace use of TI components which have **not** been so designated is solely at the Buyer’s risk, and that Buyer is solely responsible for compliance with all legal and regulatory requirements in connection with such use.

TI has specifically designated certain components as meeting ISO/TS16949 requirements, mainly for automotive use. In any case of use of non-designated products, TI will not be responsible for any failure to meet ISO/TS16949.

Products

Audio	www.ti.com/audio
Amplifiers	amplifier.ti.com
Data Converters	dataconverter.ti.com
DLP® Products	www.dlp.com
DSP	dsp.ti.com
Clocks and Timers	www.ti.com/clocks
Interface	interface.ti.com
Logic	logic.ti.com
Power Mgmt	power.ti.com
Microcontrollers	microcontroller.ti.com
RFID	www.ti-rfid.com
OMAP Applications Processors	www.ti.com/omap
Wireless Connectivity	www.ti.com/wirelessconnectivity

Applications

Automotive and Transportation	www.ti.com/automotive
Communications and Telecom	www.ti.com/communications
Computers and Peripherals	www.ti.com/computers
Consumer Electronics	www.ti.com/consumer-apps
Energy and Lighting	www.ti.com/energy
Industrial	www.ti.com/industrial
Medical	www.ti.com/medical
Security	www.ti.com/security
Space, Avionics and Defense	www.ti.com/space-avionics-defense
Video and Imaging	www.ti.com/video

TI E2E Community

e2e.ti.com