

Excellent Integrated System Limited

Stocking Distributor

Click to view price, real time Inventory, Delivery & Lifecycle Information:

[Molex Connector Corporation](#)
[0397000202](#)

For any questions, you can email us directly:

sales@integrated-circuit.com

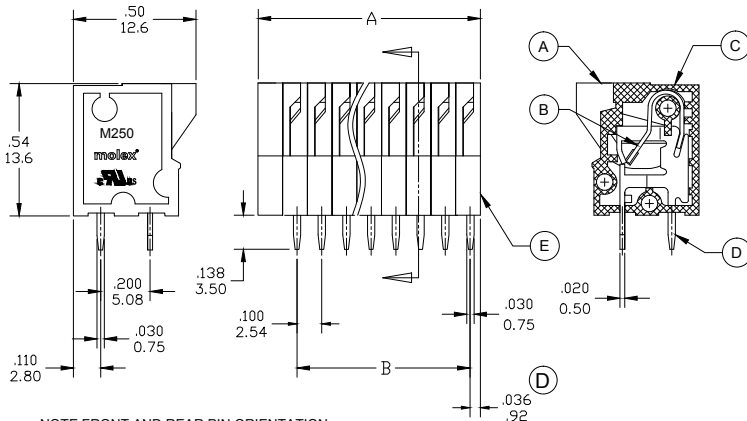

NOTE FRONT AND REAR PIN ORIENTATION

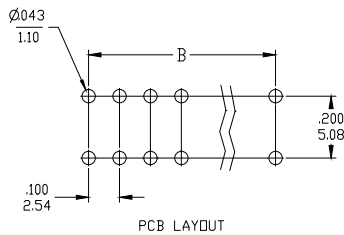

SPECIFICATIONS:

- MATERIAL:
 - A. BUTTON: PA66 UL94 V-0
 - B. SPRING: ST. STEEL
 - C. BODY : PA66 UL94 V-0
 - D. TERMINAL: BRASS TIN PLATED
 - E. COVER: PA66 UL94 V-0
- WIRE SIZE: 26 - 18AWG
- ELECTRICAL RATING (UL): 150V, 6A
- WIRE STRIP LENGTH: .43 (11.0mm)
- POWER FREQUENCY WITHSTAND: AC 2000V FDR 1 MINUTE
- INSULATION RESISTANCE: DC 500V, 500MΩ
- RATED IMPULSE VOLTAGE: 2500V PLUS AND MINUS 5 TIMES EACH
- OPERATING TEMPERATURE: -40°C TO +115°C
- MAX SOLDERING TEMPERATURE: +260°C FOR 5 SECONDS
- DIMS SHOWN ARE FOR REFERENCE ONLY

| PART NUMBER DATA | | | | | | | |
|------------------|-------------|--------------------|-------|------|------|-------|-------|
| CIRCUITS | PART NUMBER | ENGINEERING NUMBER | COLOR | A IN | mm | B IN | mm |
| 2 | 397000202 | M250-01-1-02-3 | GREEN | .30 | 7.6 | .100 | 2.54 |
| 3 | 397000203 | M250-01-1-03-3 | GREEN | .40 | 10.2 | .200 | 5.08 |
| 4 | 397000204 | M250-01-1-04-3 | GREEN | .50 | 12.7 | .300 | 7.62 |
| 5 | 397000205 | M250-01-1-05-3 | GREEN | .60 | 15.2 | .400 | 10.16 |
| 6 | 397000206 | M250-01-1-06-3 | GREEN | .70 | 17.8 | .500 | 12.70 |
| 7 | 397000207 | M250-01-1-07-3 | GREEN | .80 | 20.3 | .600 | 15.24 |
| 8 | 397000208 | M250-01-1-08-3 | GREEN | .90 | 22.9 | .700 | 17.78 |
| 9 | 397000209 | M250-01-1-09-3 | GREEN | 1.00 | 25.4 | .800 | 20.32 |
| 10 | 397000210 | M250-01-1-10-3 | GREEN | 1.10 | 27.9 | .900 | 22.86 |
| 11 | 397000211 | M250-01-1-11-3 | GREEN | 1.20 | 30.5 | 1.000 | 25.40 |
| 12 | 397000212 | M250-01-1-12-3 | GREEN | 1.30 | 33.0 | 1.100 | 27.94 |
| 13 | 397000213 | M250-01-1-13-3 | GREEN | 1.40 | 35.6 | 1.200 | 30.48 |
| 14 | 397000214 | M250-01-1-14-3 | GREEN | 1.50 | 38.1 | 1.300 | 33.02 |
| 15 | 397000215 | M250-01-1-15-3 | GREEN | 1.60 | 40.6 | 1.400 | 35.56 |
| 16 | 397000216 | M250-01-1-16-3 | GREEN | 1.70 | 43.2 | 1.500 | 38.10 |
| 17 | 397000217 | M250-01-1-17-3 | GREEN | 1.80 | 45.7 | 1.600 | 40.64 |
| 18 | 397000218 | M250-01-1-18-3 | GREEN | 1.90 | 48.3 | 1.700 | 43.18 |
| 19 | 397000219 | M250-01-1-19-3 | GREEN | 2.00 | 50.8 | 1.800 | 45.72 |
| 20 | 397000220 | M250-01-1-20-3 | GREEN | 2.10 | 53.3 | 1.900 | 48.26 |
| 21 | 397000221 | M250-01-1-21-3 | GREEN | 2.20 | 55.9 | 2.000 | 50.80 |
| 22 | 397000222 | M250-01-1-22-3 | GREEN | 2.30 | 58.4 | 2.100 | 53.34 |
| 23 | 397000223 | M250-01-1-23-3 | GREEN | 2.40 | 61.0 | 2.200 | 55.88 |
| 24 | 397000224 | M250-01-1-24-3 | GREEN | 2.50 | 63.5 | 2.300 | 58.42 |

CONTACT FACTORY FOR OPTIONAL COLORS

ENGINEERING NUMBER LEGEND

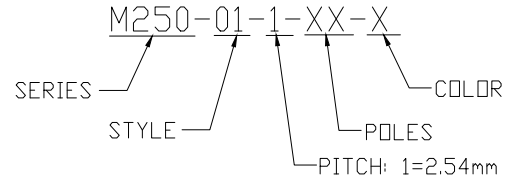

| | | | | | | | | | |
|---|------------------------------|---|--|--------------------------|--------------------|---|------------------------------|------------------------|--|
| REV'D P/N CL PER 3D MODEL EC NO: JPC2016-1082 DRWN: RSTONE 2/4/16 CHKD: B GARDEN 20/5/09/20 APPR: BRUPERT 20/31/2/26 REV D | QUALITY SYMBOL ▽=0 ∇=0 | GENERAL TOLERANCES (UNLESS SPECIFIED) | | DIMENSION STYLE IN/MM | | SCALE --- | DESIGN UNITS METRIC | THIRD ANGLE PROJECTION | |
| | | 4 PLACES ±-- ±-- 3 PLACES ±-- ±.005 2 PLACES ±0.13 ±.01 1 PLACE ±0.3 ±-- | mm INCH ±-- ±-- ±.005 ±.01 ±0.13 ±.01 ±0.3 ±-- | DRAWN BY RSTONE | DATE 2013/10/02 | TITLE SPRING TERMINAL BLOCK .100 (2.54) PITCH VERTICAL MODULAR | | | |
| | | ANGULAR ±--° | | CHECKED BY G FARNSW | DATE 2013/12/20 | MOLEX INCORPORATED | | | |
| | | DRAFT WHERE APPLICABLE MUST REMAIN WITHIN DIMENSIONS | | APPROVED BY JFMURPHY | DATE 2013/12/26 | MATERIAL NO. SEE CHART | DOCUMENT NO. SD-39700-002 | SHEET NO. 1 OF 1 | |

THIS DRAWING CONTAINS INFORMATION THAT IS PROPRIETARY TO MOLEX INCORPORATED AND SHOULD NOT BE USED WITHOUT WRITTEN PERMISSION