

Excellent Integrated System Limited

Stocking Distributor

Click to view price, real time Inventory, Delivery & Lifecycle Information:

[Semtech](#)

[EZ1085CM-3.3TRT](#)

For any questions, you can email us directly:

sales@integrated-circuit.com



POWER MANAGEMENT

Description

The EZ1085 series of high performance positive voltage regulators are designed for use in applications requiring low dropout performance at up to 3A. Additionally, the EZ1085 series provides excellent regulation over variations in line, load and temperature.

Outstanding features include low dropout performance at rated current, fast transient response, internal current limiting and thermal shutdown protection of the output device.

A variety of options are available for maximum flexibility: the EZ1085C has both fixed and adjustable voltage options and is designed for use in commercial applications and the EZ1085I is adjustable only for industrial applications.

All devices are available in the popular TO-220 and TO-263 packages.

Features

- ◆ Low dropout voltage: 1.3V max. for EZ1085C, 1.4V max. for EZ1085I
- ◆ Full current rating over line and temperature
- ◆ Fast transient response
- ◆ ±2% total output regulation over line, load and temperature
- ◆ Adjust pin current max 90µA over temperature
- ◆ Fixed/adjustable output voltage (EZ1085C)
- ◆ Line regulation typically 0.015%
- ◆ Load regulation typically 0.05%
- ◆ Industrial temperature range (EZ1085I)
- ◆ TO-220 and TO-263 packages. Available in RoHS compliant package

Applications

- ◆ Printer and plotter supplies
- ◆ Instrumentation
- ◆ Medical equipment
- ◆ Microcontroller systems
- ◆ Telecommunication systems
- ◆ Motherboards
- ◆ Switching supply post regulation

Typical Application Circuit

Fixed Voltage Regulator

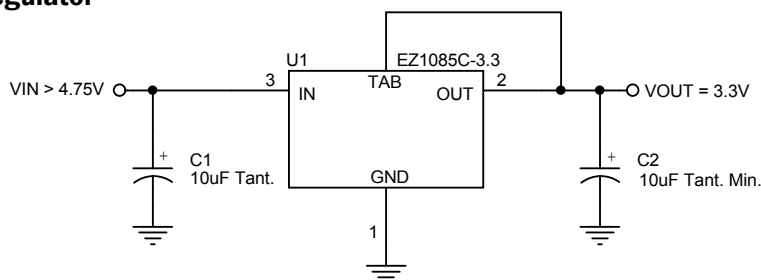

Adjustable Voltage Regulator

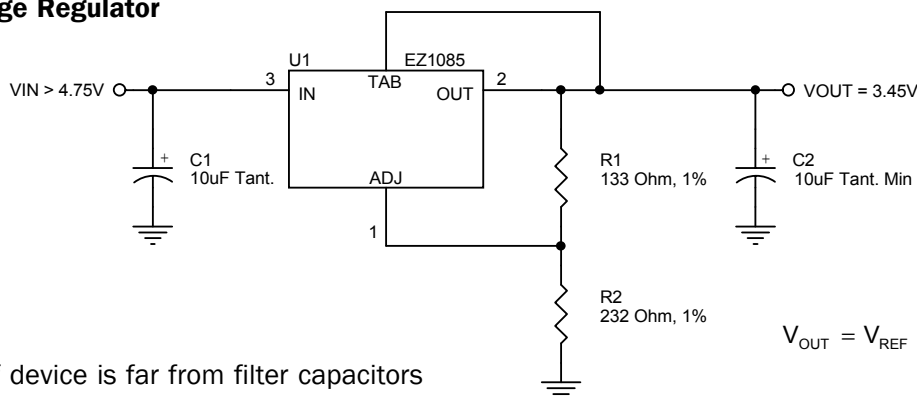

Notes:

- (1) C1 needed if device is far from filter capacitors
- (2) C2 minimum value required for stability

$$V_{OUT} = V_{REF} \cdot \left(1 + \frac{R2}{R1}\right) + I_{ADJ} \cdot R2$$



POWER MANAGEMENT

Absolute Maximum Ratings

Exceeding the specifications below may result in permanent damage to the device, or device malfunction. Operation outside of the parameters specified in the Electrical Characteristics section is not implied.

Parameter	Symbol	Maximum	Units
Input Supply Voltage	V_{IN}	7	V
Power Dissipation	P_D	Internally Limited	W
Thermal Resistance Junction to Case TO-220 TO-263	θ_{JC}	3 3	$^{\circ}C/W$
Thermal Resistance Junction to Ambient TO-220 TO-263	θ_{JA}	50 60	$^{\circ}C/W$
Operating Ambient Temperature Range EZ1085C EZ1085I	T_A	0 to 70 -40 to 85	$^{\circ}C$
Operating Junction Temperature Range EZ1085C EZ1085I	T_J	0 to 125 -40 to 125	$^{\circ}C$
Storage Temperature Range	T_{STG}	-65 to 150	$^{\circ}C$
Lead Temperature (Soldering) 10 Sec.	T_{LEAD}	300	$^{\circ}C$
ESD Rating (Human Body Model)	ESD	2	kV

Electrical Characteristics

Unless otherwise specified: Adj. $V_{IN} = 2.75V$ to $7.0V$ and Adj. $I_O = 10mA$ to $3A$; Fixed $V_{IN} = 4.75$ to $7.0V$ and Fixed $I_O = 0$ mA to $3A$.
 Values in **bold** apply over full operating ambient temperature range.

Parameter	Symbol	V_{IN}	I_O	Min	Typ	Max	Units
Output Voltage ⁽¹⁾ EZ1085C-X.X	V_O	5V	0mA	$0.985V_O$ $0.98V_O$	V_O	$1.015V_O$ $1.02V_O$	V
Reference Voltage ⁽¹⁾ EZ1085C, EZ1085I	V_{REF}	5V	10mA	1.231 1.225	1.250	1.269 1.275	V
Reference Voltage ⁽¹⁾	V_{RE}	5V	10mA	1.233	1.250	1.267	V
Line Regulation ⁽¹⁾	$REG_{(LINE)}$		10mA		0.045	0.2	%
Load Regulation ⁽¹⁾	$REG_{(LOAD)}$	5V			0.15	0.4	%
Dropout Voltage ⁽¹⁾⁽²⁾ EZ1085C, EZ1085C-X.X EZ1085I	V_D		3A		1.20 1.20	1.35 1.40	V
Current Limit	I_{CL}			3.0	4.5		A



POWER MANAGEMENT

Electrical Characteristics (Cont)

Unless otherwise specified: Adj. V_{IN} = 2.75V to 7.0V and Adj. I_O = 10mA to 3A; Fixed V_{IN} = 4.75 to 7.0V and Fixed I_O = 0 mA to 3A.
 Values in **bold** apply over full operating ambient temperature range.

Parameter	Symbol	V_{IN}	I_O	Min	Typ	Max	Units
Quiescent Current Fixed Voltage Version	I_Q	5V			10	14	mA
Temperature Coefficient	T_C				0.005		%/°C
Adjust Pin Current	I_{ADJ}				55	90	μA
Adjust Pin Current Change	ΔI_{ADJ}				0.2	5	μA
Temperature Stability	T_S	5V	0.5A		0.5		%
Minimum Load Current Adj Voltage Versions	I_O	5V			5	10	mA
RMS Output Noise ⁽³⁾	V_N				0.003		% V_O
Ripple Rejection Ratio ⁽⁴⁾	R_A	5V	3A	60	72		dB

NOTES:

- (1) Low duty cycle pulse testing with Kelvin connections required.
- (2) $\Delta V_{OUT}, \Delta V_{REF} = 1\%$
- (3) Bandwidth of 10 Hz to 10 kHz.
- (4) 120 Hz input ripple (C_{ADJ} for ADJ = 25μF).



POWER MANAGEMENT

Pin Configurations

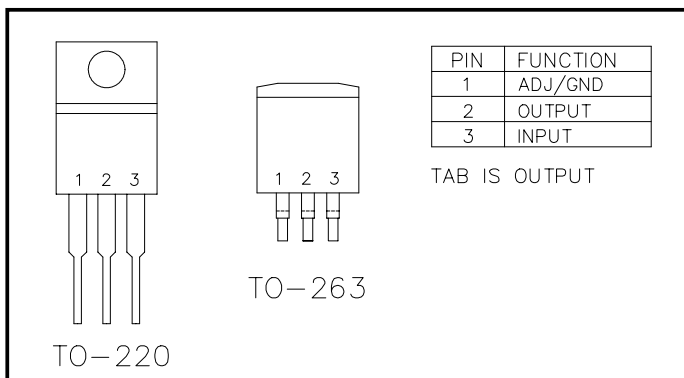

Ordering Information

Device ⁽¹⁾⁽²⁾	Package
EZ1085CM-X.X.TR EZ1085IM.TR EZ1085CM-X.XTRT ⁽⁵⁾ EZ1085IMTRT ⁽⁵⁾	TO-263 ⁽³⁾
EZ1085CT-X.X EZ1085IT EZ1085CT-X.XT ⁽⁵⁾ EZ1085ITT ⁽⁵⁾	TO-220 ⁽⁴⁾

Notes:

- (1) Where X.X denotes voltage options (EZ1085C only). Available voltages are: 2.5V and 3.3V. Leave blank for adjustable version (1.3 to 5.7V). Contact factory for additional voltage options.
- (2) Where C and I denote Commercial (0°C to 70°C) and Industrial (-40°C to 85°C) ambient temperature ranges.
- (3) Only available in tape and reel packaging. A reel contains 800 devices.
- (4) Only available in tube packaging. A tube contains 50 devices.
- (5) This product is RoHS compliant.

Pin Descriptions

Pin	Pin Name	Pin Function
1	ADJUST	This pin is the negative side of the reference voltage for adjustable devices. Transient response can be improved by adding a small bypass capacitor from the adjust pin to ground.
	GROUND	This pin is the bottom end of the internal resistor feedback chain for fixed output voltage parts, and should be connected to ground.
2	OUTPUT	This is the power output of the device and is electrically connected to the TAB.
3	INPUT	This is the input supply pin for both the control circuitry and the pass device.

Block Diagram

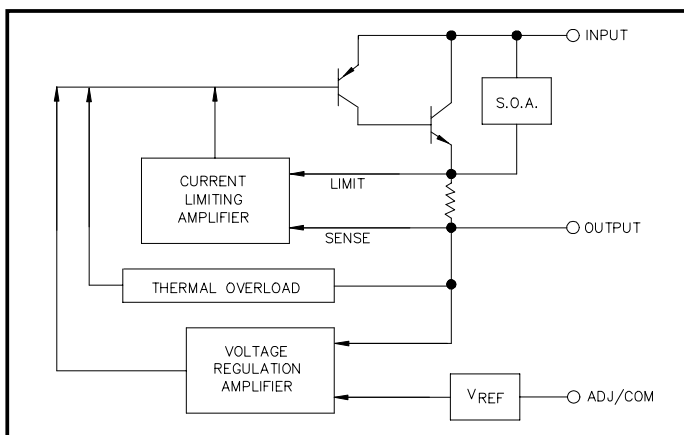



POWER MANAGEMENT

Outline Drawing - TO-220

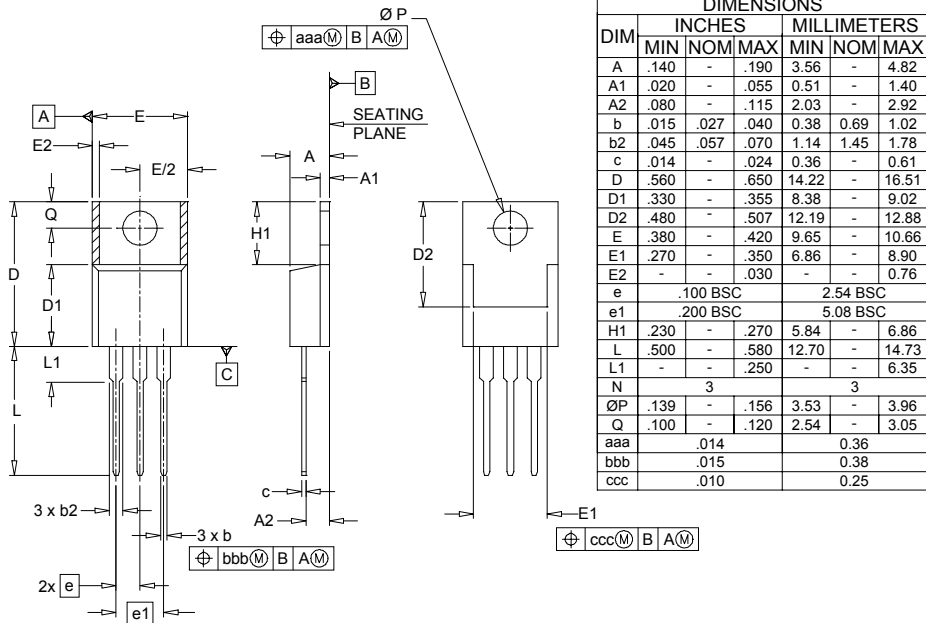

- NOTES:
1. CONTROLLING DIMENSIONS ARE IN INCHES.
 2. DIMENSIONS "D" AND "E" DO NOT INCLUDE MOLD FLASH, PROTRUSIONS OR GATE BURRS.

Outline Drawing - TO-263

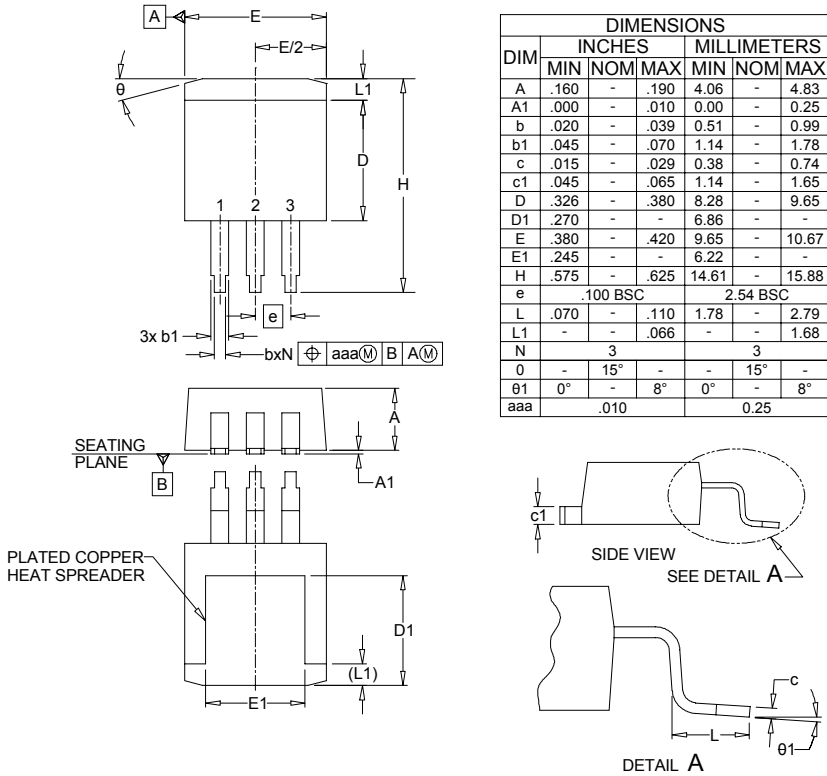

- NOTES:
1. CONTROLLING DIMENSIONS ARE IN INCHES (ANGLES IN DEGREES).
 2. DIMENSIONS "D" AND "E" DO NOT INCLUDE MOLD FLASH, PROTRUSIONS OR GATE BURRS.



POWER MANAGEMENT

Land Pattern - TO-263

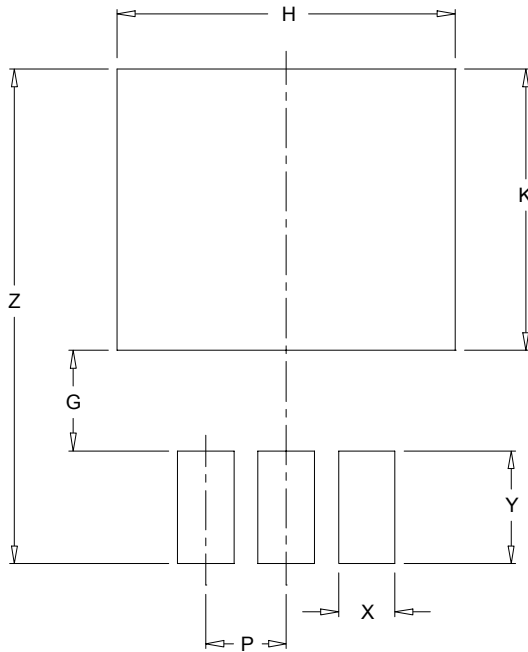

DIMENSIONS		
DIM	INCHES	MILLIMETERS
G	.125	3.17
H	.420	10.67
K	.350	8.89
P	.100	2.54
X	.070	1.78
Y	.140	3.56
Z	.615	15.62

NOTES:

1. THIS LAND PATTERN IS FOR REFERENCE PURPOSES ONLY
 CONSULT YOUR MANUFACTURING GROUP TO ENSURE YOUR
 COMPANY'S MANUFACTURING GUIDELINES ARE MET.

Contact Information

Semtech Corporation
 Power Management Products Division
 200 Flynn Road, Camarillo, CA. 93012
 Phone: (805)498-2111 FAX (805)498-3804