

Excellent Integrated System Limited

Stocking Distributor

Click to view price, real time Inventory, Delivery & Lifecycle Information:

[Advanced Photonix, Inc.](#)
[PDI-M304](#)

For any questions, you can email us directly:

sales@integrated-circuit.com

PHOTONIC DETECTORS INC.

1.06 Micron, High Speed Silicon Photodiode Quadrant Type PDI-M304

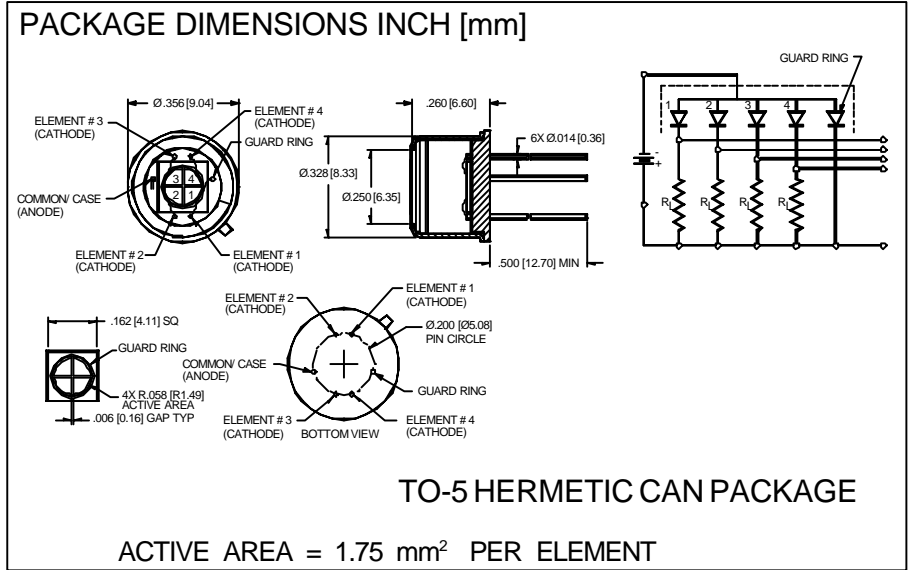
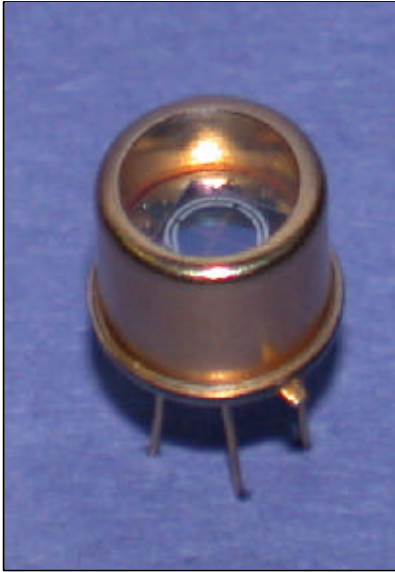

FEATURES

- .45 A/W @1060 nm
- 11 ns response time
- Low noise

DESCRIPTION

The **PDI-M304** is a high speed photodiode, processed on high resistivity P type silicon. Guard ring construction for enhanced 1060 nm response and 28 Mhz bandwidth. Packaged in a 6 leaded hermetic TO-5 hermetic package. Ideal for Nd YAG laser.

APPLICATIONS

- YAG laser detection
- Navigation
- Tracking and Aligning

ABSOLUTE MAXIMUM RATING (TA=25°C unless otherwise noted)

SYMBOL	PARAMETER	MIN	MAX	UNITS
V _{BR}	Reverse Voltage		75	V
T _{STG}	Storage Temperature	-55	+125	°C
T _O	Operating Temperature Range	-40	+100	°C
T _S	Soldering Temperature*		+260	°C
I _L	Light Current		500	mA

*1/16 inch from case for 3 secs max

SPECTRAL RESPONSE

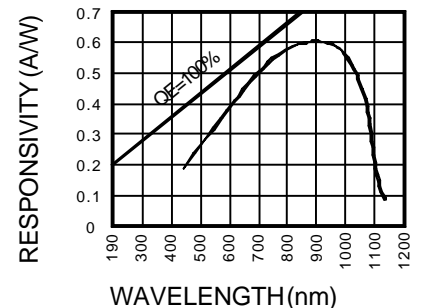

ELECTRO-OPTICAL CHARACTERISTICS (TA=25°C unless otherwise noted)

SYMBOL	CHARACTERISTIC	TEST CONDITIONS	MIN	TYP	MAX	UNITS
I _{SC}	Short Circuit Current	H = 100 fc, 2850 K	49	52		μA
I _D	Dark Current	H = 0, V _R = 200 V		1.4	50	pA
R _{SH}	Shunt Resistance	H = 0, V _R = 10 mV		-		MΩ
TCR _{SH}	RSH Temp. Coefficient	H = 0, V _R = 10 mV		-10		% / °C
C _J	Junction Capacitance	H = 0, V _R = 200 V**		1.2	1.4	pF
λ _{range}	Spectral Application Range	Spot Scan	400		1150	nm
λ _p	Spectral Response - Peak	Spot Scan		900		nm
V _{BR}	Breakdown Voltage	I = 1 μA	250	450		V
NEP	Noise Equivalent Power	V _R = 10 V @ 900 nm		1.5x10 ⁻¹¹		W/√Hz
tr	Response Time	RL = 50Ω V _R = 200 V		11		nS

Information in this technical data sheet is believed to be correct and reliable. However, no responsibility is assumed for possible inaccuracies or omission. Specifications are subject to change without notice. **f = 1 MHz [FORM NO. 100-PDI-M304 REV A]