

Excellent Integrated System Limited

Stocking Distributor

Click to view price, real time Inventory, Delivery & Lifecycle Information:

[Molex Connector Corporation](#)
[0690156001](#)

For any questions, you can email us directly:

sales@integrated-circuit.com



APPLICATOR No. 69015-6001
PRODUCT NUMBER 90100/103 22-26 AWG

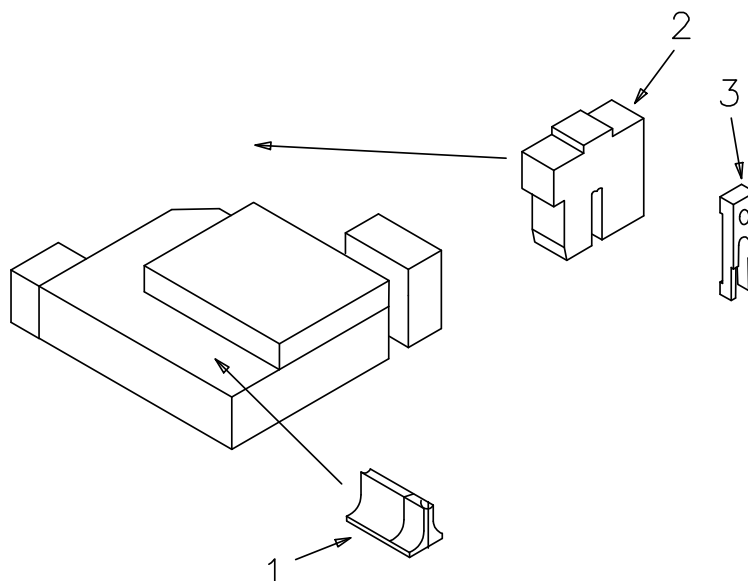

ITEM	PART NUMBER	DESCRIPTION
1	-69,015	CRIMP ANVIL
2	-69,015	CRIMP DIE
3	-69,015	INSULATION DIE
4	-69,015	TOOK KIT (ITEMS 1-3)

PRODUCT SPECIFICATION: (SEE ALSO PRODUCT SPEC. CS. 90100/103)

WIRE mm ² (AWG)	CRIMP HEIGHT (COND)	PULL FORCE (MIN)
0.11/0.03 (28-32)	0.59/0.66 mm (.023"/.026")	See AS 90100

WIRE STRIP LENGTH: - 2.8 / 3.3 mm (.110"/.130")