

## Excellent Integrated System Limited

Stocking Distributor

Click to view price, real time Inventory, Delivery & Lifecycle Information:

[Molex Connector Corporation](#)  
[0690371039](#)

For any questions, you can email us directly:

[sales@integrated-circuit.com](mailto:sales@integrated-circuit.com)



APPLICATOR No. 69037-1039  
 PRODUCT No. 90422-0109

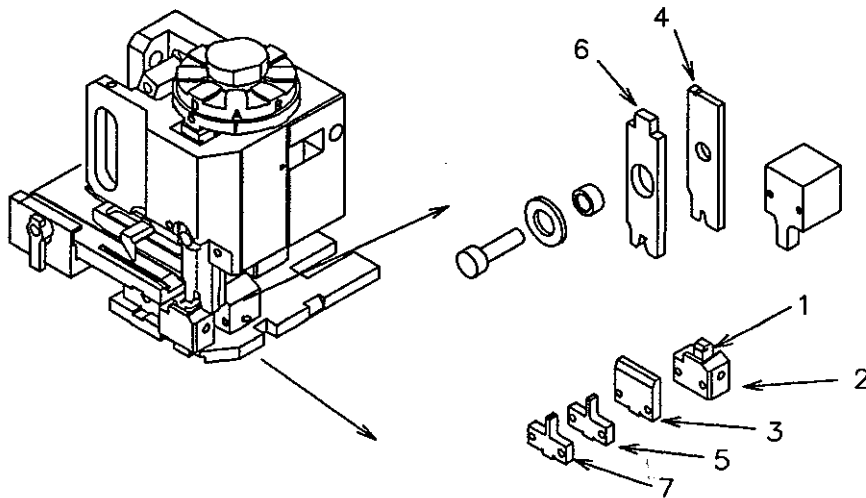

ITEM	PART NUMBER	DESCRIPTION
1	69037-0129	REAR SHEAR PUNCH
2	69037-0095	REAR SHEAR DIE
3	69037-0214	REAR SHEAR PLATE
4	69039-1521	CONDUCTOR PUNCH
5	69039-3518	CONDUCTOR ANVIL
6	69039-2528	INSULATION PUNCH
7	69039-4521	INSULATION ANVIL
8	69037-2039	TOOL KIT (ITEMS 4 - 7)

CRIMP SPECIFICATION: (SEE ALSO PRODUCT SPEC. CS.90422)

WIRE mm <sup>2</sup> (AWG)	CRIMP HEIGHT (COND)
0.75	1.60/1.65mm (.063"/.065")
1.25	1.78/1.85mm (.070"/.073")

WIRE STRIP LENGTH: - 4.25 / 4.75mm (0.167" / 0.187")