



Distributor of API Technologies Corp: Excellent Integrated System Limited

Datasheet of 572019-00100-70 - CONN MICRO-D PLUG

Contact us: sales@integrated-circuit.com Website: www.integrated-circuit.com

Excellent Integrated System Limited

Stocking Distributor

Click to view price, real time Inventory, Delivery & Lifecycle Information:

[API Technologies Corp](#)
[572019-00100-70](#)

For any questions, you can email us directly:

sales@integrated-circuit.com



Waved Metal Gaskets



Proper mounting of an EMI filter is critical to achieving optimum filtering performance. For applications requiring very high attenuation, it is necessary to fill the gaps at the mounting surface-to-connector interface. The length of any gap must be short, relative to the wavelength of the signal to be attenuated. Spectrum Control supplies a line of "waved" gaskets. This design ensures the maximum "gap length" will not exceed the wave pitch, .200" (5.08mm), even on surfaces with poor flatness. This ensures maximum filter performance to 1GHz and beyond.

Specifications

Material Beryllium Copper, CA 172 (per QQ-C-533)
Finish -70 Electro tin plate, 100 micro inches (per MIL-T-10727)
 NI nickel plated, AU gold plated

Material Thickness005" (.13mm) compressed

Wave Height030"+.020/-.015 (.76+.51/-.38mm)

Length increase when flattened 0.008" (.20mm) per inch

Waved Metal Grounding/Shielding Gasket (shown in free state)

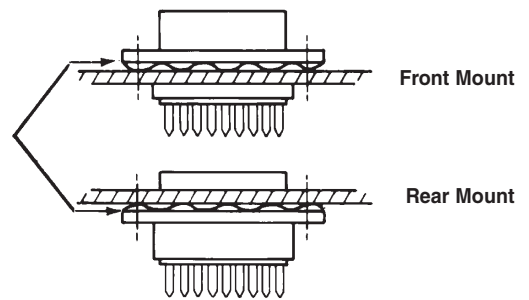

Wave Height



Ordering Information *Select part number by filling in "xxx": 572019-00xxx-70*

Mounting: Front mounted pin or socket connector, rear mounted pin connector.						
Shell Size	A ±.020 (0.51)	B ±.020 (0.51)	C ±.020 (0.51)	D ±.020 (0.51)	E ±.005 (0.13)	"xxx"
9	1.213 (30.81)	.984 (24.99)	.777 (19.74)	.600 (15.24)	.440 (11.18)	100
15	1.541 (39.14)	1.312 (33.32)	1.105 (28.07)	.600 (15.24)	.440 (11.18)	101
25	2.088 (53.04)	1.852 (47.04)	1.645 (41.78)	.600 (15.24)	.440 (11.18)	102
37	2.729 (69.32)	2.500 (63.50)	2.293 (58.24)	.600 (15.24)	.440 (11.18)	103
50	2.635 (66.93)	2.406 (61.11)	2.190 (55.63)	.710 (18.03)	.550 (13.97)	104

Mounting: Rear mounted socket connectors only.								
Shell Size	A ±.020 (0.51)	B ±.020 (0.51)	C ±.020 (0.51)	D ±.020 (0.51)	E ±.005 (0.13)	F ±.005 (0.13)	G ±.020 (0.51)	"xxx"
9	1.213 (30.81)	.984 (24.99)	.450 (11.43)	.660 (16.76)	.324 (8.23)	.360 (9.14)	.600 (15.24)	105
15	1.541 (39.14)	1.312 (33.32)	.670 (17.02)	.988 (25.10)	.324 (8.23)	.360 (9.14)	.600 (15.24)	106
25	2.088 (53.04)	1.852 (47.04)	1.110 (28.19)	1.528 (38.81)	.324 (8.23)	.360 (9.14)	.600 (15.24)	107
37	2.729 (69.32)	2.500 (63.50)	1.550 (39.37)	2.176 (55.27)	.324 (8.23)	.360 (9.14)	.600 (15.24)	108
50	2.635 (66.93)	2.406 (61.11)	1.550 (39.37)	2.082 (52.88)	.436 (11.07)	.470 (11.94)	.710 (18.03)	109

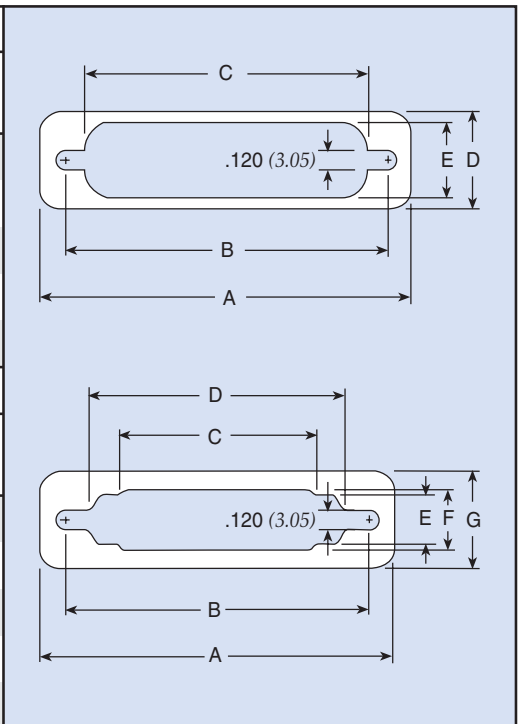

Dimensions in inches (mm)