

Excellent Integrated System Limited

Stocking Distributor

Click to view price, real time Inventory, Delivery & Lifecycle Information:

[Amphenol Sine Systems](#)

[AT60-215-16141](#)

For any questions, you can email us directly:

sales@integrated-circuit.com

| REVISIONS | | | | | |
|-----------|-----|-----------------------------|-----------|-------|------|
| REV | ECO | DESCRIPTION | DATE | BY | APPR |
| A4 | - | RELEASE NEW DWG FORMAT | 16/JUL/13 | JARRY | - |
| A5 | - | ADDED COLOR BAND | 16DEC2015 | JAH | - |
| A6 | - | MATCHED DIMS TO NEW TOOLING | 28JAN2015 | JAH | - |

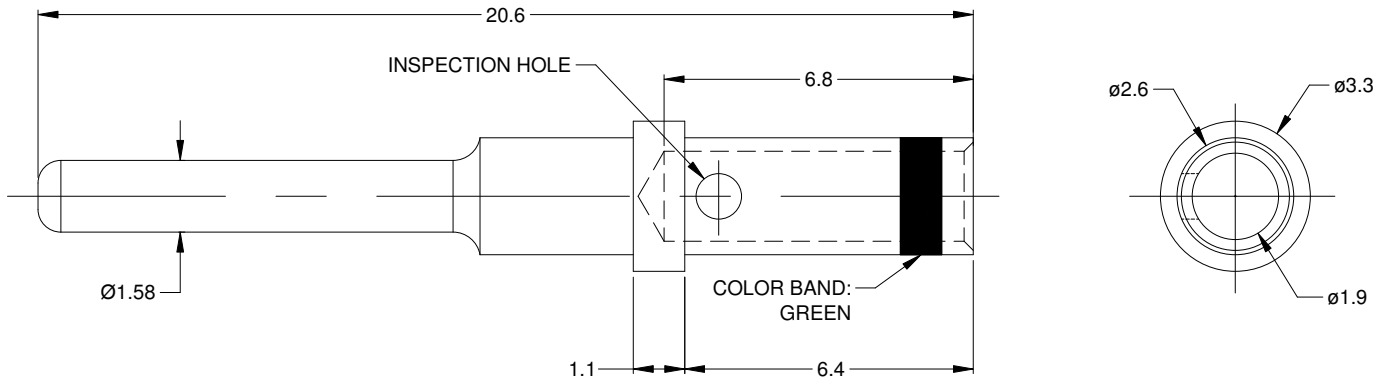

NOTES: UNLESS OTHERWISE SPECIFIED

1. MATERIAL: COPPER ALLOY

2. PLATING: SEE PART NUMBER CHART

3. CONTACT SIZE: 16

4. SPECIFICATIONS:

4.1 CURRENT RATING: 13 AMPS

4.2 CONTACT MILLIVOLT DROP: 60 MILLIVOLT DROP @ 13 AMP TEST CURRENT.

4.3 RoHS COMPLIANT

5. RECOMMENDED WIRE RANGE: 14 AWG

6. AVAILABLE HAND CRIMPER: CA-5D12

7. ALL DIMENSIONS ARE FOR REFERENCE USE ONLY

| PART NUMBER CHART | |
|-------------------|----------------|
| PLATING | PART NUMBER |
| GOLD | AT60-215-1631 |
| NICKEL | AT60-215-16141 |

| | | | | |
|--|--|--------------|---|------------|
| SEE PART NUMBER CHART | | | | |
| PART NUMBER | | DESCRIPTION | | ITEM |
| QUANTITY | MATERIALS LIST | | | |
| UNLESS OTHERWISE SPECIFIED 1) All dimensions are in metric(mm). 2) Tolerances are as follows: 1 PL DEC ±0.30 2 PL DEC ±0.15 3 PL DEC ±0.08 3) Note reference = | SIGNATURES | DATE | Sine Systems - www.amphenol-sine.com 44724 Morley Drive Clinton Township, MI 48036 CONTACT, PIN, SOLID, SIZE 16, 14AWG, AT/AHD-9 SERIES | |
| | DRAWN: JARRY | 16/JUL/13 | | |
| CHECKED: | | | | |
| ENGINEER: | | | | |
| MATERIAL SPECIFICATIONS: | APPROVAL: | | CUSTOMER: | |
| PROCESS SPECIFICATIONS: | THIS DRAWING IS SUPPLIED FOR INFORMATION ONLY. DESIGN FEATURES, SPECIFICATIONS AND PERFORMANCE DATA SHOWN HEREON ARE THE PROPERTY OF THE AMPHENOL CORPORATION. NO RIGHTS OF REPRODUCTION ARE IMPLIED. ALL DIMENSIONS ARE SUBJECT TO NORMAL MANUFACTURING VARIATIONS. | | SIZE: A C- | TYPE: NONE |
| NEXT ASSY: | DWG NO: AT60-215-16XXX | REVISION: A6 | SHEET 1 OF 1 | |