

## Excellent Integrated System Limited

Stocking Distributor

Click to view price, real time Inventory, Delivery & Lifecycle Information:

[STMicroelectronics](#)

[STH12N120K5-2](#)

For any questions, you can email us directly:

[sales@integrated-circuit.com](mailto:sales@integrated-circuit.com)



# STH12N120K5-2, STP12N120K5, STW12N120K5, STWA12N120K5

N-channel 1200 V, 0.62 Ω typ., 12 A MDmesh K5 Power MOSFETs  
 in H<sup>2</sup>PAK-2, TO-220, TO-247 and TO-247 long leads

Datasheet - production data

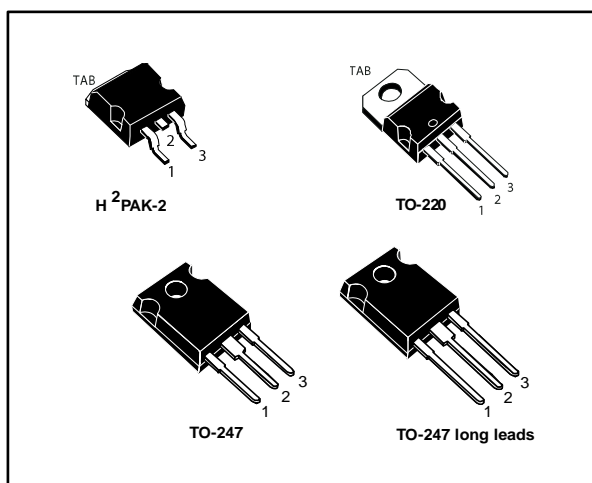

Figure 1: Internal schematic diagram

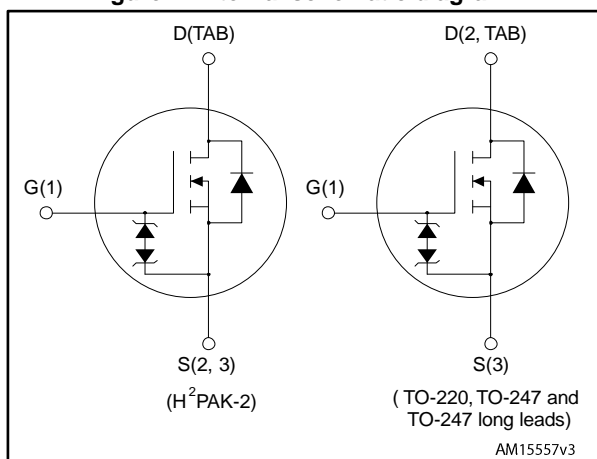

Table 1: Device summary

Order code	Marking	Package	Packing
STH12N120K5-2	12N120K5	H <sup>2</sup> PAK-2	Tape and reel
STP12N120K5		TO-220	Tube
STW12N120K5		TO-247	
STWA12N120K5		TO-247 long leads	

## Features

Order codes	V <sub>DS</sub>	R <sub>DS(on)</sub> max.	I <sub>D</sub>	P <sub>TOT</sub>
STH12N120K5-2	1200 V	0.69 Ω	12 A	250 W
STP12N120K5				
STW12N120K5				
STWA12N120K5				

- Worldwide best FOM (figure of merit)
- Ultra-low gate charge
- 100% avalanche tested
- Zener-protected

## Applications

- Switching applications

## Description

These very high voltage N-channel Power MOSFETs are designed using MDmesh™ K5 technology based on an innovative proprietary vertical structure. The result is a dramatic reduction in on-resistance and ultra-low gate charge for applications requiring superior power density and high efficiency.

Contents

STH12N120K5-2, STP12N120K5,  
STW12N120K5, STWA12N120K5

---

## Contents

<b>1</b>	<b>Electrical ratings .....</b>	<b>3</b>
<b>2</b>	<b>Electrical characteristics .....</b>	<b>4</b>
2.1	Electrical characteristics (curves) .....	6
<b>3</b>	<b>Test circuits .....</b>	<b>9</b>
<b>4</b>	<b>Package information .....</b>	<b>10</b>
4.1	H <sup>2</sup> PAK-2 package information .....	11
4.2	TO-220 type A package information .....	14
4.3	TO-247 package information .....	16
4.4	TO-247 long leads package information .....	18
<b>5</b>	<b>Revision history .....</b>	<b>20</b>

STH12N120K5-2, STP12N120K5,  
 STW12N120K5, STWA12N120K5

Electrical ratings

# 1 Electrical ratings

Table 2: Absolute maximum ratings

Symbol	Parameter	Value	Unit
$V_{GS}$	Gate-source voltage	$\pm 30$	V
$I_D$	Drain current at $T_C = 25\text{ }^\circ\text{C}$	12	A
$I_D$	Drain current at $T_C = 100\text{ }^\circ\text{C}$	7.6	A
$I_{DM}^{(1)}$	Drain current (pulsed)	48	A
$P_{TOT}$	Total dissipation at $T_C = 25\text{ }^\circ\text{C}$	250	W
$I_{AR}^{(2)}$	Max current during repetitive or single pulse avalanche	4	A
$E_{AS}^{(3)}$	Single pulse avalanche energy	215	mJ
$dv/dt^{(4)}$	Peak diode recovery voltage slope	4.5	V/ns
$dv/dt^{(5)}$	MOSFET $dv/dt$ ruggedness	50	V/ns
$T_j$ $T_{stg}$	Operating junction temperature Storage temperature	- 55 to 150	$^\circ\text{C}$

**Notes:**

(1) Pulse width limited by safe operating area.

(2) Pulse width limited by  $T_{Jmax}$ .

(3) Starting  $T_J = 25\text{ }^\circ\text{C}$ ,  $I_D = I_{AS}$ ,  $V_{DD} = 50\text{ V}$

(4)  $I_{SD} \leq 12\text{ A}$ ,  $di/dt \leq 100\text{ A}/\mu\text{s}$ ,  $V_{Peak} \leq V_{(BR)DSS}$

(5)  $V_{DS} \leq 960\text{ V}$

Table 3: Thermal data

Symbol	Parameter	Value			Unit
		H <sup>2</sup> PAK-2	TO-220	TO-247 TO-247 long leads	
$R_{thj-case}$	Thermal resistance junction-case max	0.5			$^\circ\text{C}/\text{W}$
$R_{thj-amb}$	Thermal resistance junction-amb max		62.5	50	$^\circ\text{C}/\text{W}$
$R_{thj-pcb}$	Thermal resistance junction-pcb max	30			$^\circ\text{C}/\text{W}$

**Electrical characteristics**
**STH12N120K5-2, STP12N120K5,  
STW12N120K5, STWA12N120K5**

## 2 Electrical characteristics

 (T<sub>CASE</sub> = 25 °C unless otherwise specified)

**Table 4: On/off states**

Symbol	Parameter	Test conditions	Min.	Typ.	Max.	Unit
V <sub>(BR)DSS</sub>	Drain-source breakdown voltage	V <sub>GS</sub> = 0 V, I <sub>D</sub> = 1 mA	1200			V
I <sub>DSS</sub>	Zero gate voltage drain current	V <sub>GS</sub> = 0 V, V <sub>DS</sub> = 1200 V			1	μA
		V <sub>GS</sub> = 0, V <sub>DS</sub> = 1200 V, T <sub>C</sub> = 125 °C			50	μA
I <sub>GSS</sub>	Gate body leakage current	V <sub>DS</sub> = 0 V, V <sub>GS</sub> = ± 20 V			±10	μA
V <sub>GS(th)</sub>	Gate threshold voltage	V <sub>DS</sub> = V <sub>GS</sub> , I <sub>D</sub> = 100 μA	3	4	5	V
R <sub>DS(on)</sub>	Static drain-source on-resistance	V <sub>GS</sub> = 10 V, I <sub>D</sub> = 6 A		0.62	0.69	Ω

**Table 5: Dynamic**

Symbol	Parameter	Test conditions	Min.	Typ.	Max.	Unit
C <sub>iss</sub>	Input capacitance	V <sub>GS</sub> = 0 V, V <sub>DS</sub> = 100 V, f = 1 MHz	-	1370	-	pF
C <sub>oss</sub>	Output capacitance		-	110	-	pF
C <sub>rss</sub>	Reverse transfer capacitance		-	0.6	-	pF
C <sub>o(tr)</sub> <sup>(1)</sup>	Equivalent capacitance, time-related	V <sub>GS</sub> = 0, V <sub>DS</sub> = 0 to 960 V	-	128	-	pF
C <sub>o(er)</sub> <sup>(2)</sup>	Equivalent capacitance, energy-related		-	42	-	pF
R <sub>G</sub>	Intrinsic gate resistance	f = 1 MHz, I <sub>D</sub> = 0 A	-	3	-	Ω
Q <sub>g</sub>	Total gate charge	V <sub>DD</sub> = 960 V, I <sub>D</sub> = 12 A V <sub>GS</sub> = 10 V (see <a href="#">Figure 18: "Gate charge test circuit"</a> )	-	44.2	-	nC
Q <sub>gs</sub>	Gate-source charge		-	7.3	-	nC
Q <sub>gd</sub>	Gate-drain charge		-	30	-	nC

**Notes:**

<sup>(1)</sup>Time-related is defined as a constant equivalent capacitance giving the same charging time as C<sub>oss</sub> when V<sub>DS</sub> increases from 0 to 80% V<sub>DSS</sub>

<sup>(2)</sup>Energy-related is defined as a constant equivalent capacitance giving the same stored energy as C<sub>oss</sub> when V<sub>DS</sub> increases from 0 to 80% V<sub>DSS</sub>

**STH12N120K5-2, STP12N120K5,  
STW12N120K5, STWA12N120K5**
**Electrical characteristics**
**Table 6: Switching times**

Symbol	Parameter	Test conditions	Min.	Typ.	Max.	Unit
$t_{d(on)}$	Turn-on delay time	$V_{DD} = 600\text{ V}$ , $I_D = 6\text{ A}$ , $R_G = 4.7\ \Omega$ , $V_{GS} = 10\text{ V}$ (see <i>Figure 20: "Unclamped inductive load test circuit"</i> )	-	23	-	ns
$t_r$	Rise time		-	11	-	ns
$t_{d(off)}$	Turn-off delay time		-	68.5	-	ns
$t_f$	Fall time		-	18.5	-	ns

**Table 7: Source drain diode**

Symbol	Parameter	Test conditions	Min.	Typ.	Max.	Unit
$I_{SD}$	Source-drain current		-		12	A
$I_{SDM}$	Source-drain current (pulsed)		-		48	A
$V_{SD}^{(1)}$	Forward on voltage	$I_{SD} = 12\text{ A}$ , $V_{GS} = 0\text{ V}$	-		1.5	V
$t_{rr}$	Reverse recovery time	$I_{SD} = 12\text{ A}$ , $V_{DD} = 60\text{ V}$ $di/dt = 100\text{ A}/\mu\text{s}$ , (see <i>Figure 19: "Test circuit for inductive load switching and diode recovery times"</i> )	-	630		ns
$Q_{rr}$	Reverse recovery charge		-	12.6		$\mu\text{C}$
$I_{RRM}$	Reverse recovery current		-	40		A
$t_{rr}$	Reverse recovery time	$I_{SD} = 12\text{ A}$ , $V_{DD} = 60\text{ V}$ $di/dt = 100\text{ A}/\mu\text{s}$ , $T_j = 150\text{ }^\circ\text{C}$ (see <i>Figure 19: "Test circuit for inductive load switching and diode recovery times"</i> )	-	892		ns
$Q_{rr}$	Reverse recovery charge		-	15.6		$\mu\text{C}$
$I_{RRM}$	Reverse recovery current		-	35		A

**Notes:**
<sup>(1)</sup>Pulsed: pulse duration = 300 $\mu\text{s}$ , duty cycle 1.5%

**Table 8: Gate-source Zener diode**

Symbol	Parameter	Test conditions	Min	Typ.	Max.	Unit
$V_{(BR)GSO}$	Gate-source breakdown voltage	$I_{GS} = \pm 1\text{ mA}$ , $I_D = 0\text{ A}$	30	-		V

The built-in back-to-back Zener diodes have been specifically designed to enhance the ESD capability of the device. The Zener voltage is appropriate for efficient and cost-effective intervention to protect the device integrity. These integrated Zener diodes thus eliminate the need for external components.

**Electrical characteristics**

**STH12N120K5-2, STP12N120K5,  
STW12N120K5, STWA12N120K5**

**2.1 Electrical characteristics (curves)**

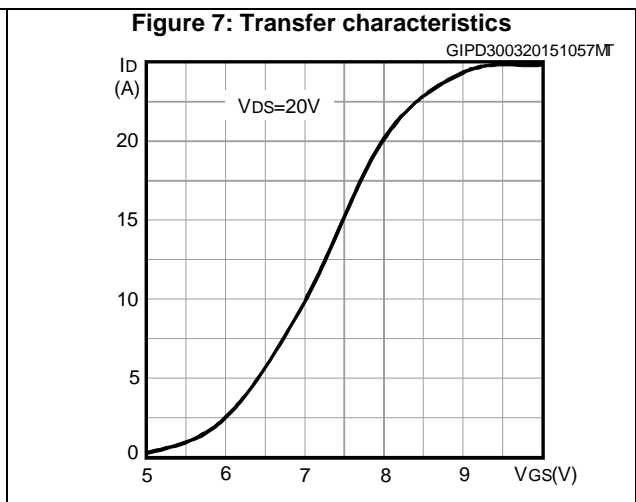
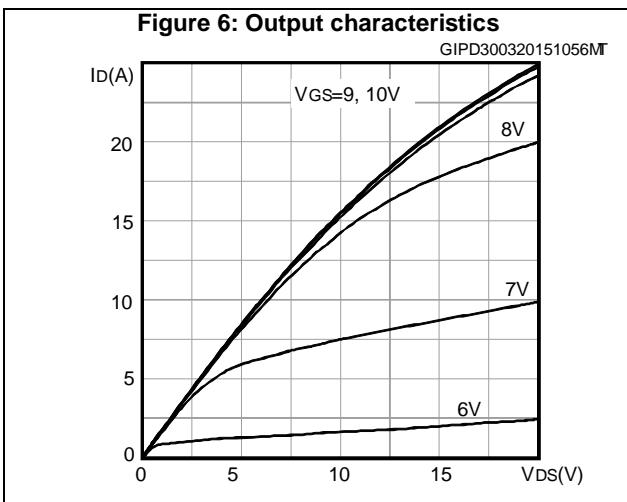
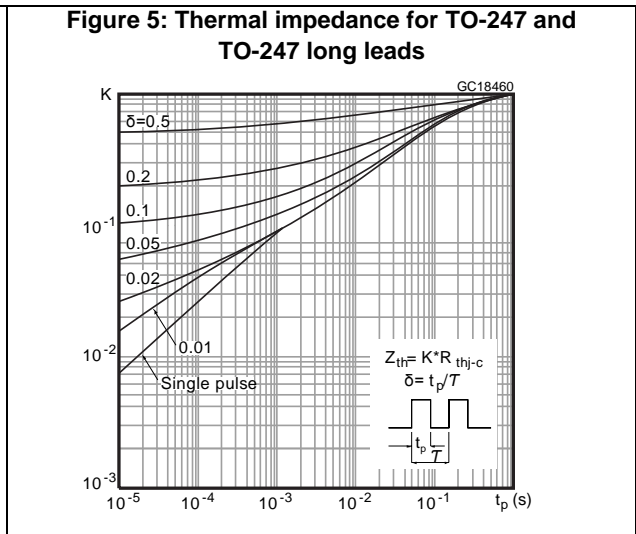
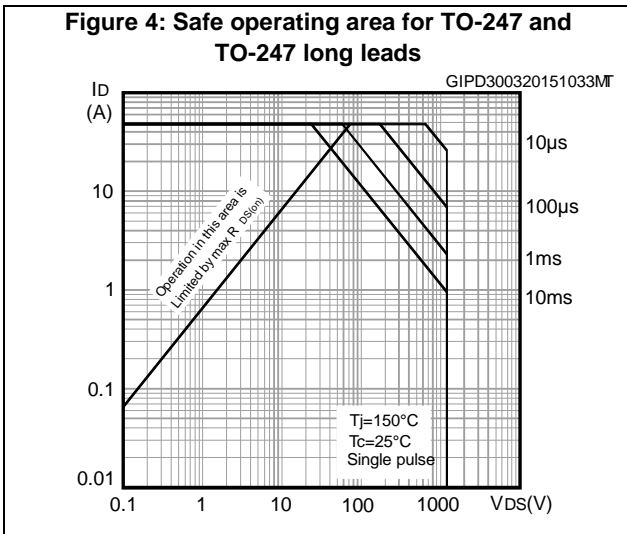
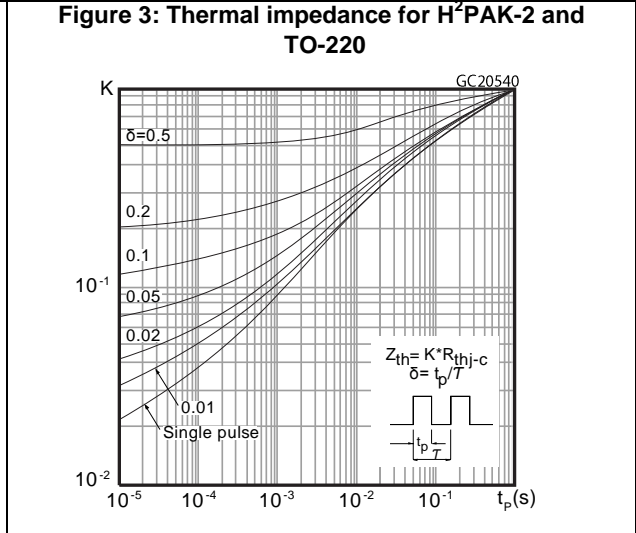
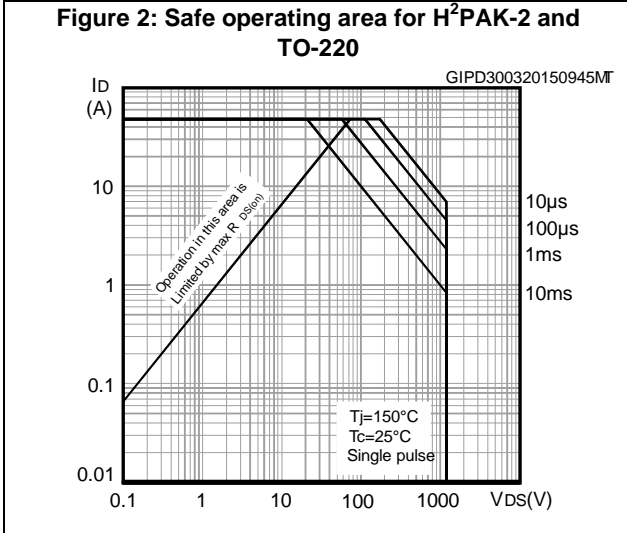

**STH12N120K5-2, STP12N120K5,  
STW12N120K5, STWA12N120K5**

**Electrical characteristics**

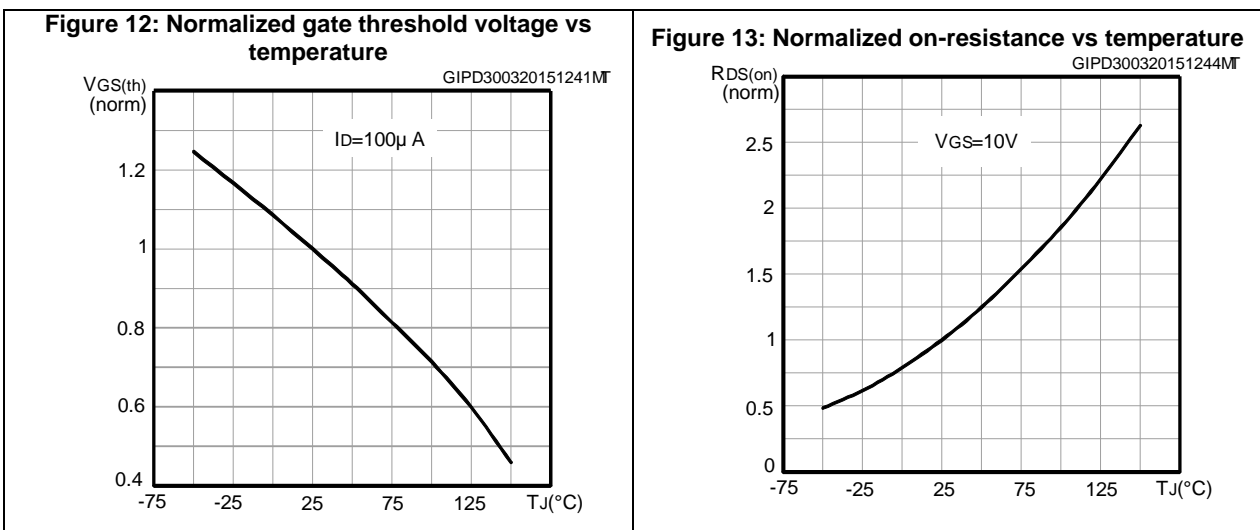
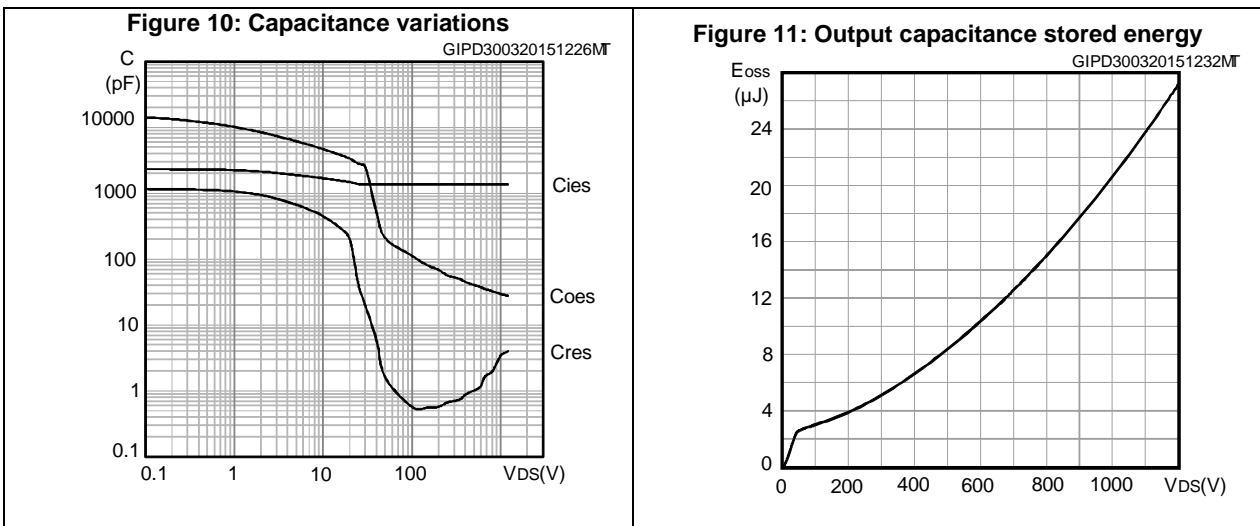
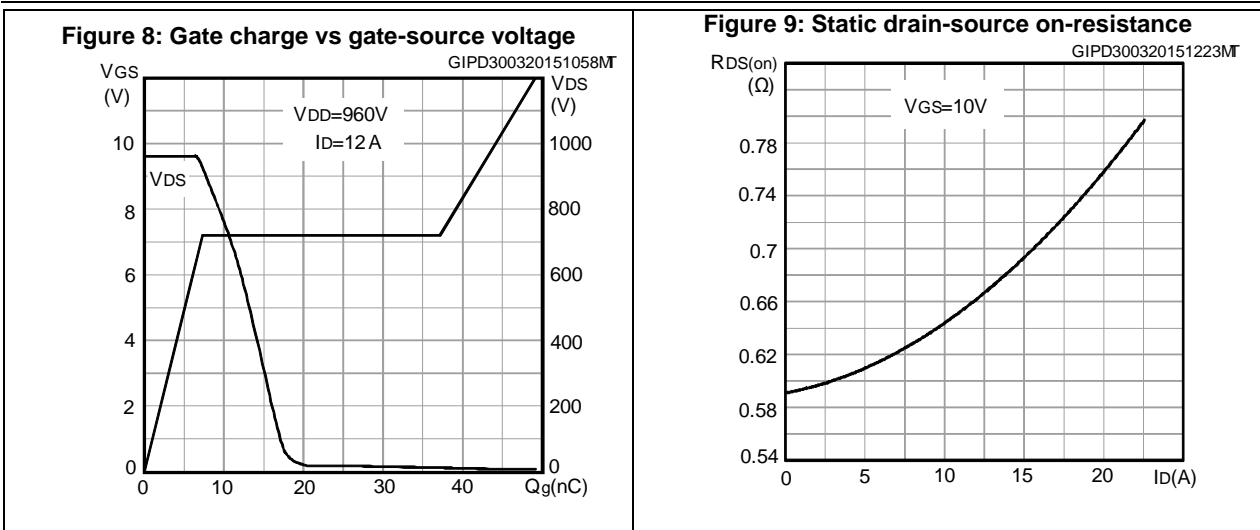



Electrical characteristics

STH12N120K5-2, STP12N120K5,  
 STW12N120K5, STWA12N120K5

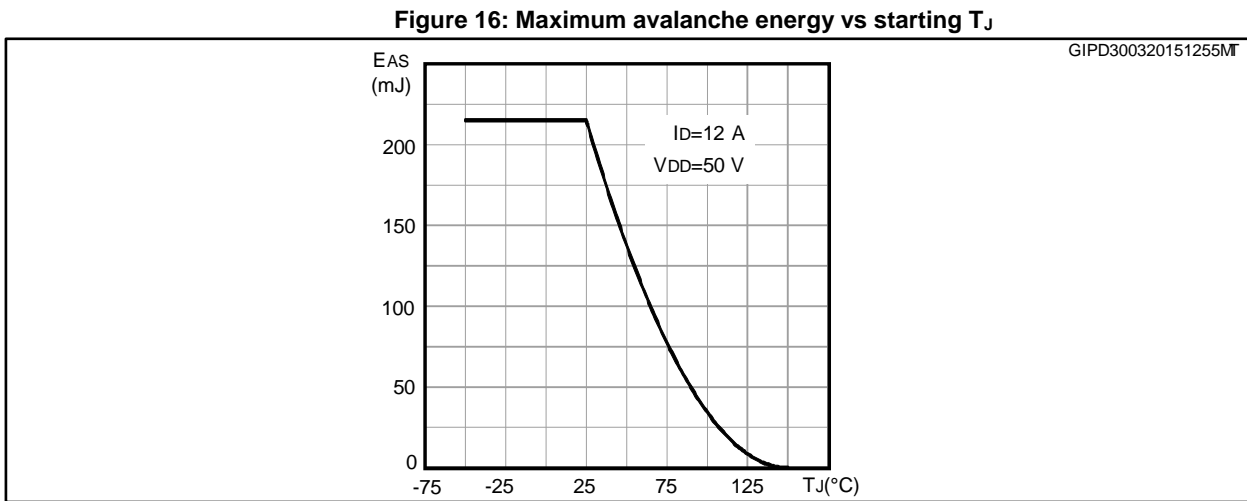
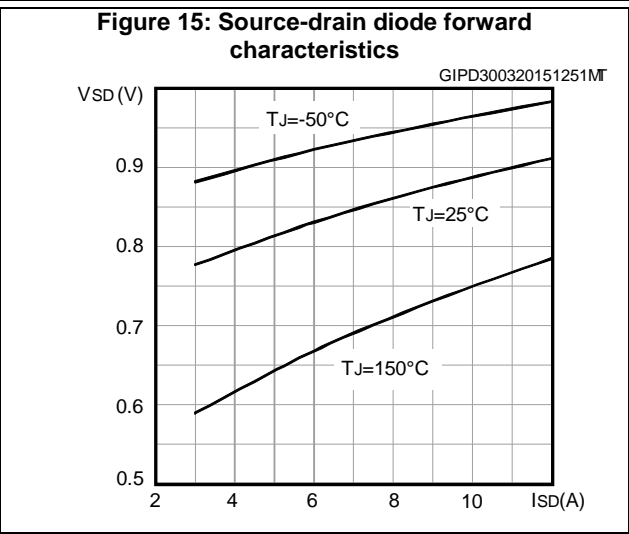
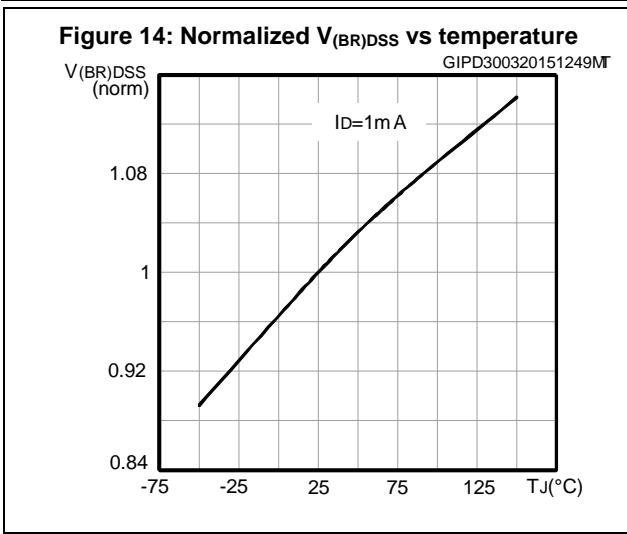

**STH12N120K5-2, STP12N120K5,  
STW12N120K5, STWA12N120K5**

**Test circuits**

**3 Test circuits**

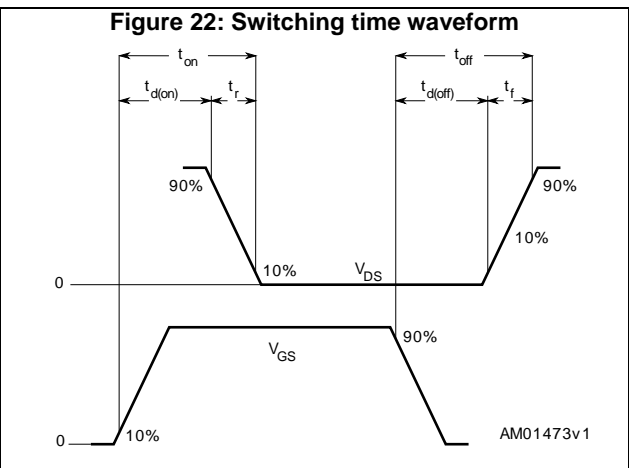
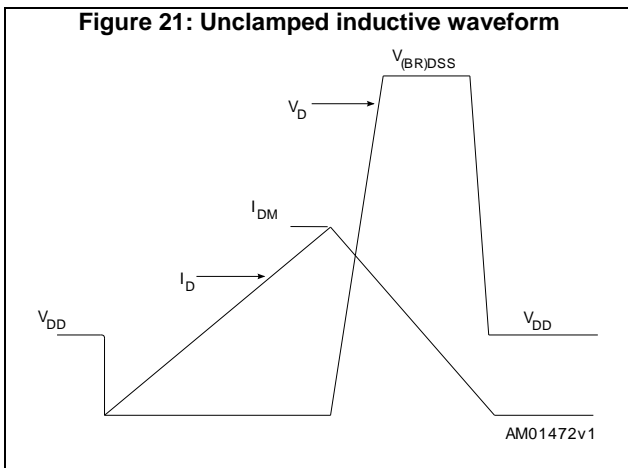
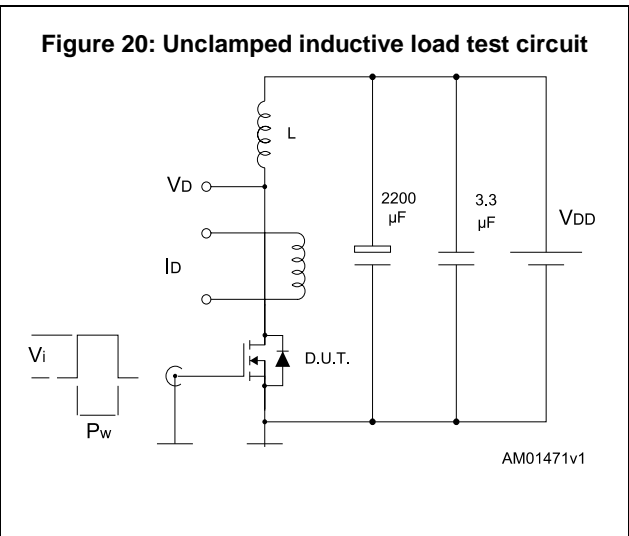
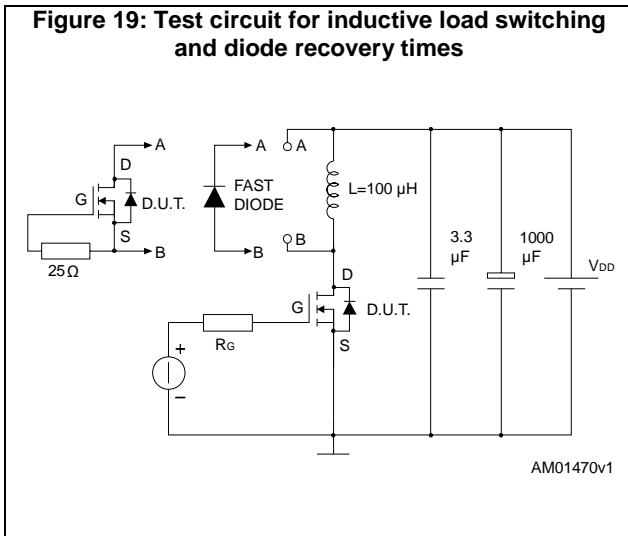
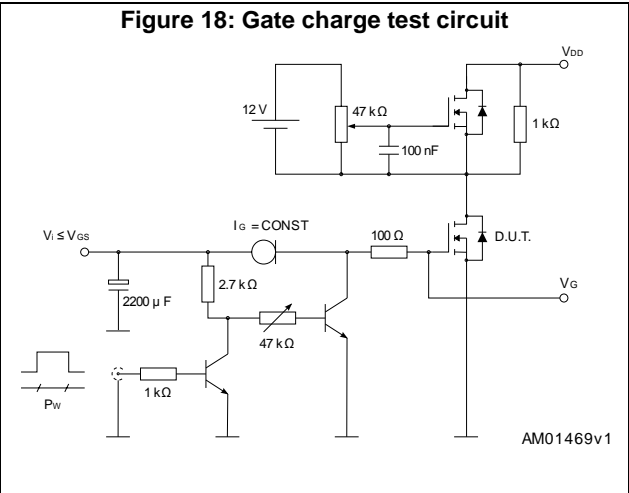
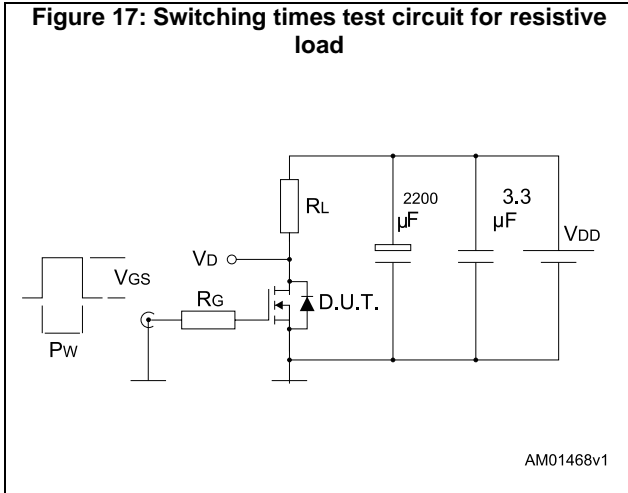

Package information

STH12N120K5-2, STP12N120K5,  
STW12N120K5, STWA12N120K5

---

## 4 Package information

In order to meet environmental requirements, ST offers these devices in different grades of ECOPACK<sup>®</sup> packages, depending on their level of environmental compliance. ECOPACK<sup>®</sup> specifications, grade definitions and product status are available at: [www.st.com](http://www.st.com). ECOPACK<sup>®</sup> is an ST trademark.

STH12N120K5-2, STP12N120K5,  
 STW12N120K5, STWA12N120K5

Package information

4.1 H<sup>2</sup>PAK-2 package information

Figure 23: H<sup>2</sup>PAK-2 package outline

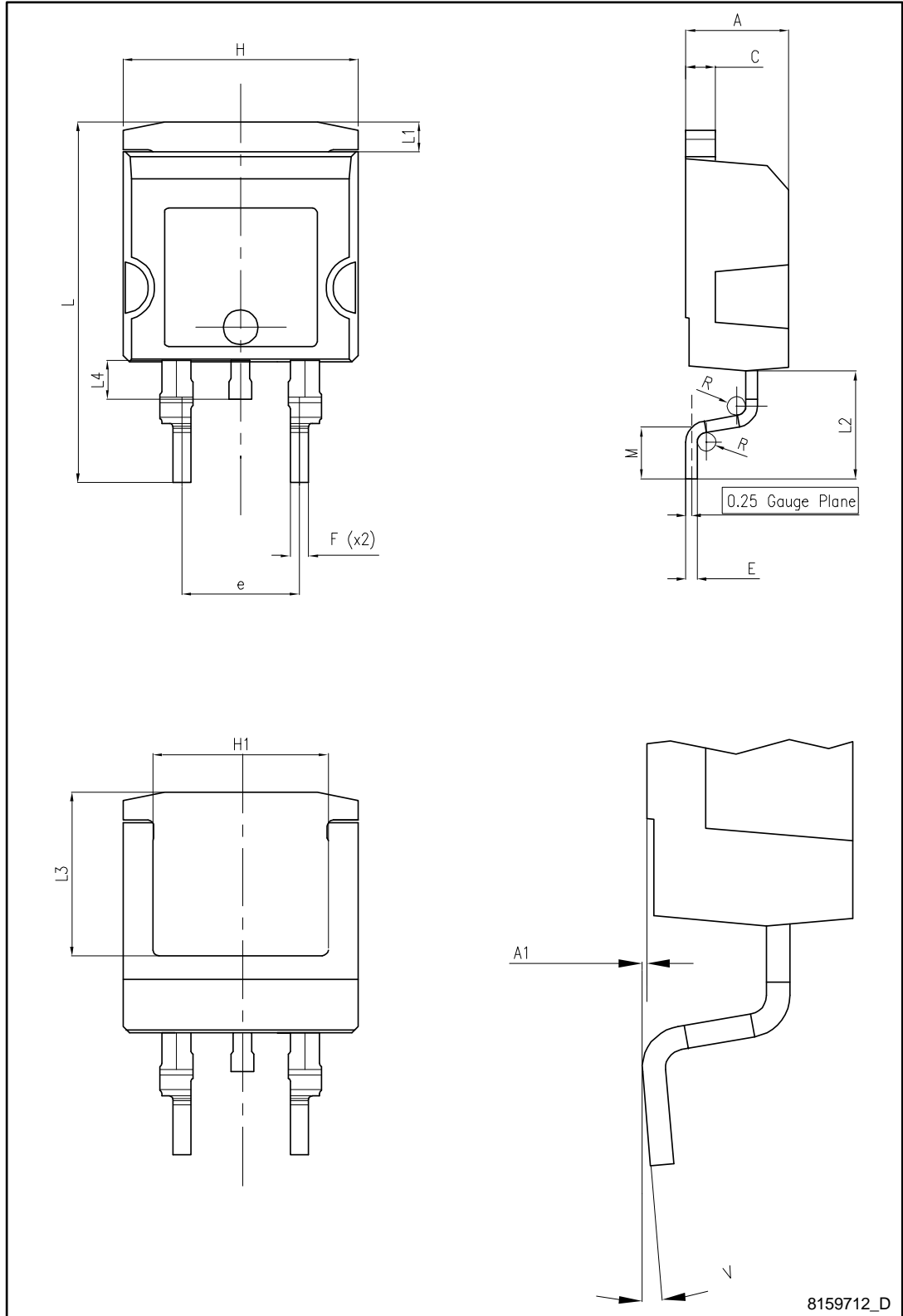

Package information

STH12N120K5-2, STP12N120K5,  
STW12N120K5, STWA12N120K5

Table 9: H<sup>2</sup>PAK-2 mechanical data

Dim.	mm		
	Min.	Typ.	Max.
A	4.30		4.80
A1	0.03		0.20
C	1.17		1.37
e	4.98		5.18
E	0.50		0.90
F	0.78		0.85
H	10.00		10.40
H1	7.40		7.80
L	15.30		15.80
L1	1.27		1.40
L2	4.93		5.23
L3	6.85		7.25
L4	1.5		1.7
M	2.6		2.9
R	0.20		0.60
V	0°		8°

STH12N120K5-2, STP12N120K5,  
STW12N120K5, STWA12N120K5

Package information

Figure 24: H<sup>2</sup>PAK-2 recommended footprint

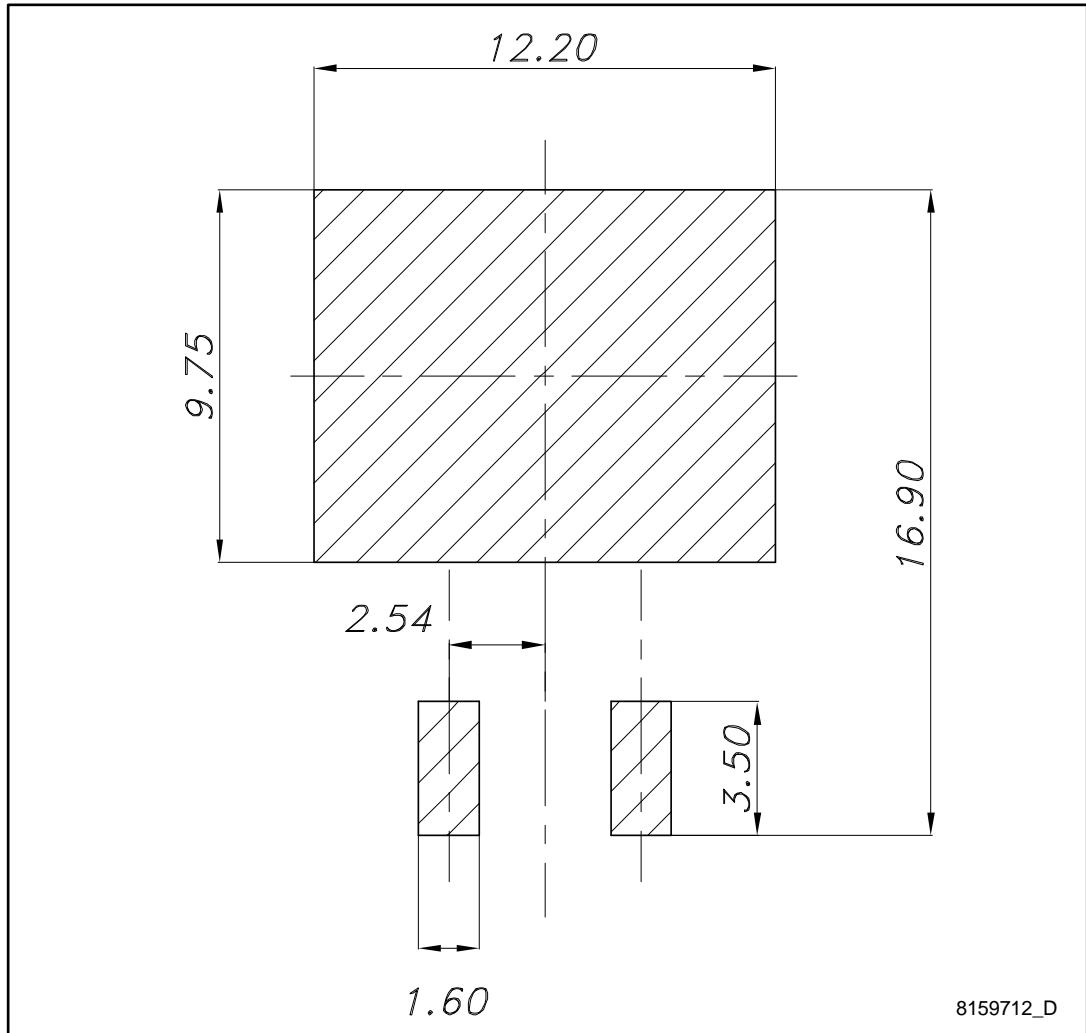

Package information

STH12N120K5-2, STP12N120K5,  
STW12N120K5, STWA12N120K5

4.2 TO-220 type A package information

Figure 25: TO-220 type A package outline

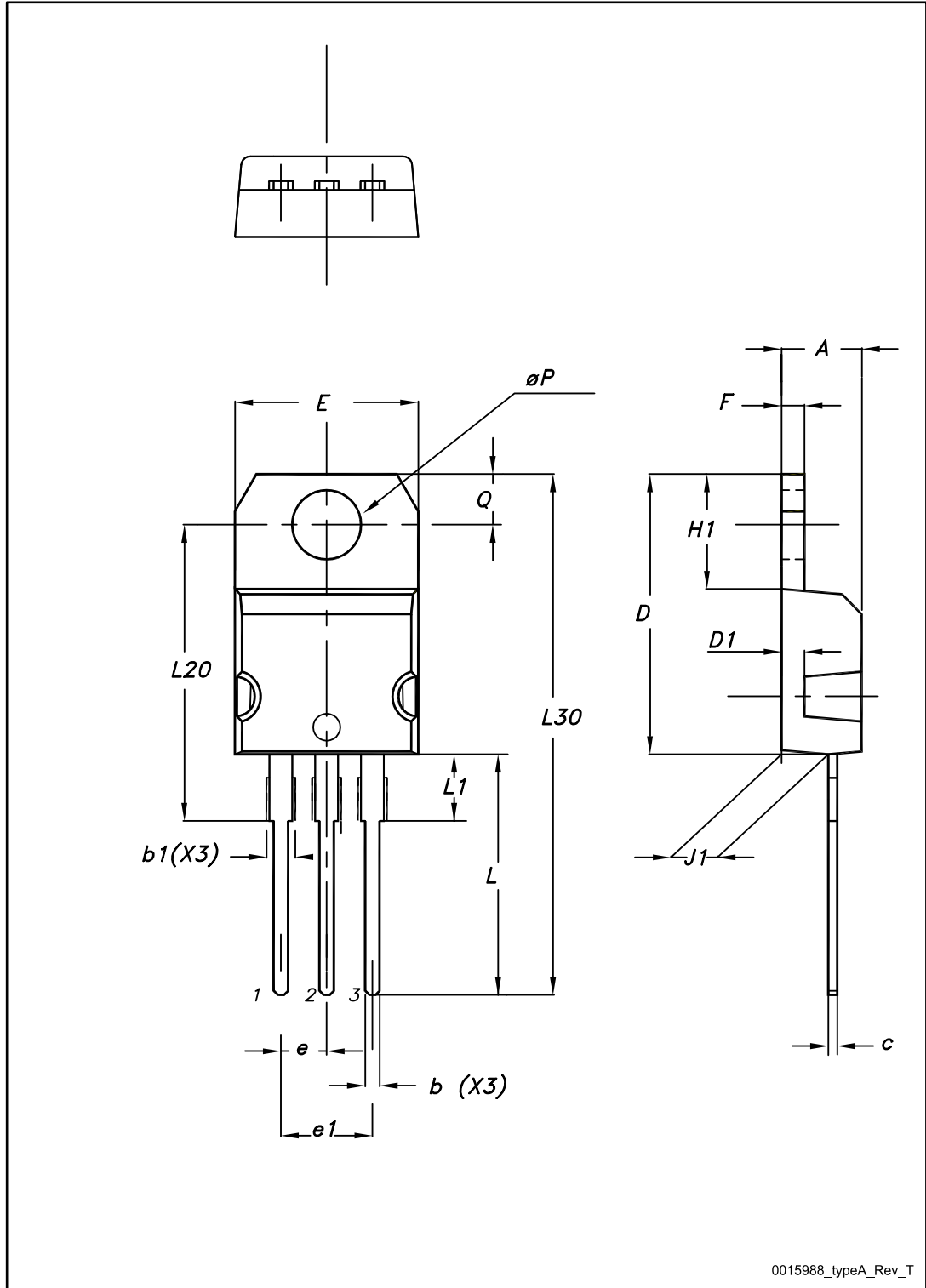

**STH12N120K5-2, STP12N120K5,  
STW12N120K5, STWA12N120K5**

**Package information**

**Table 10: TO-220 type A mechanical data**

Dim.	mm		
	Min.	Typ.	Max.
A	4.40		4.60
b	0.61		0.88
b1	1.14		1.70
c	0.48		0.70
D	15.25		15.75
D1		1.27	
E	10		10.40
e	2.40		2.70
e1	4.95		5.15
F	1.23		1.32
H1	6.20		6.60
J1	2.40		2.72
L	13		14
L1	3.50		3.93
L20		16.40	
L30		28.90	
øP	3.75		3.85
Q	2.65		2.95



Package information

STH12N120K5-2, STP12N120K5,  
 STW12N120K5, STWA12N120K5

4.3 TO-247 package information

Figure 26: TO-247 package outline

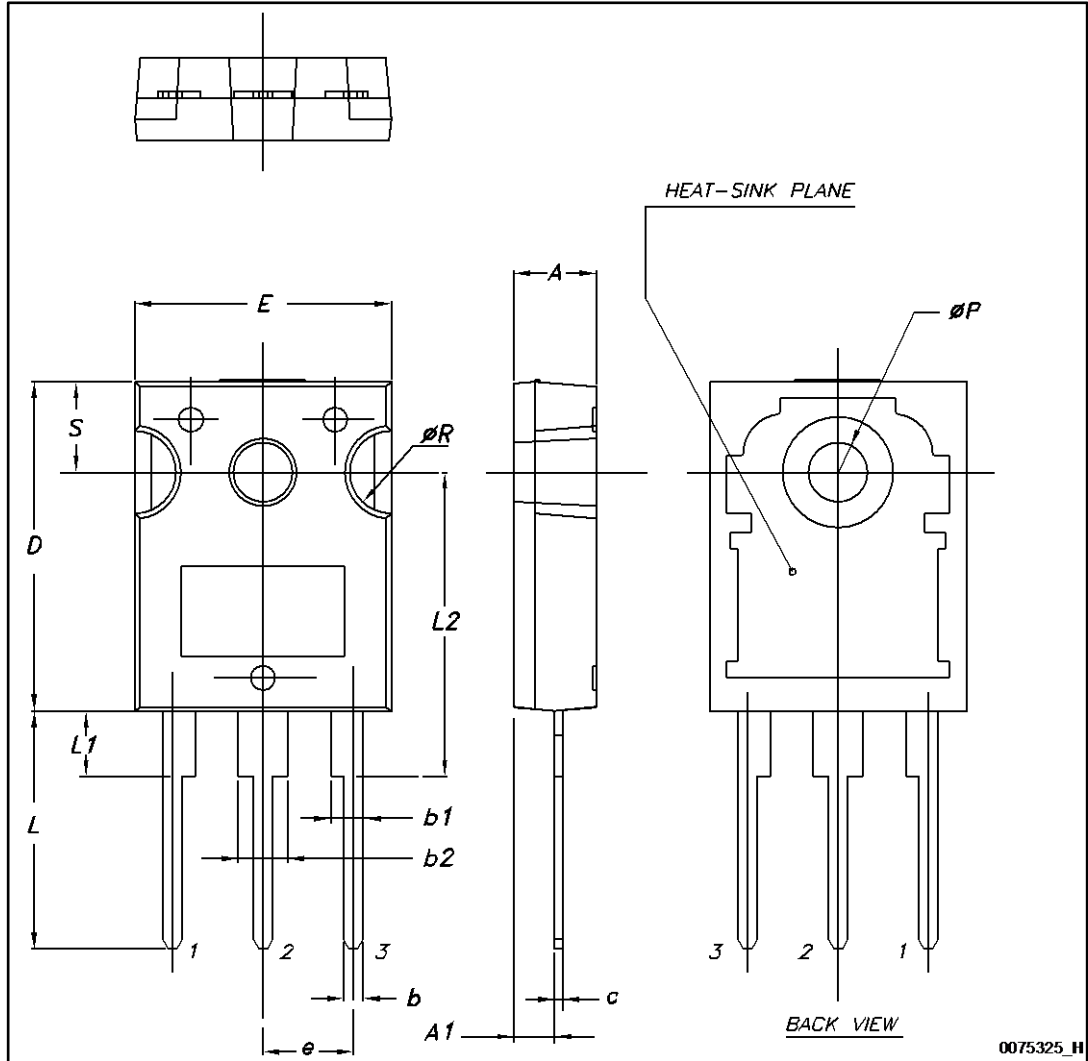

**STH12N120K5-2, STP12N120K5,  
STW12N120K5, STWA12N120K5**

**Package information**

**Table 11: TO-247 mechanical data**

Dim.	mm.		
	Min.	Typ.	Max.
A	4.85		5.15
A1	2.20		2.60
b	1.0		1.40
b1	2.0		2.40
b2	3.0		3.40
c	0.40		0.80
D	19.85		20.15
E	15.45		15.75
e	5.30	5.45	5.60
L	14.20		14.80
L1	3.70		4.30
L2		18.50	
ØP	3.55		3.65
ØR	4.50		5.50
S	5.30	5.50	5.70

Package information

STH12N120K5-2, STP12N120K5,  
 STW12N120K5, STWA12N120K5

4.4 TO-247 long leads package information

Figure 27: TO-247 long leads package outline

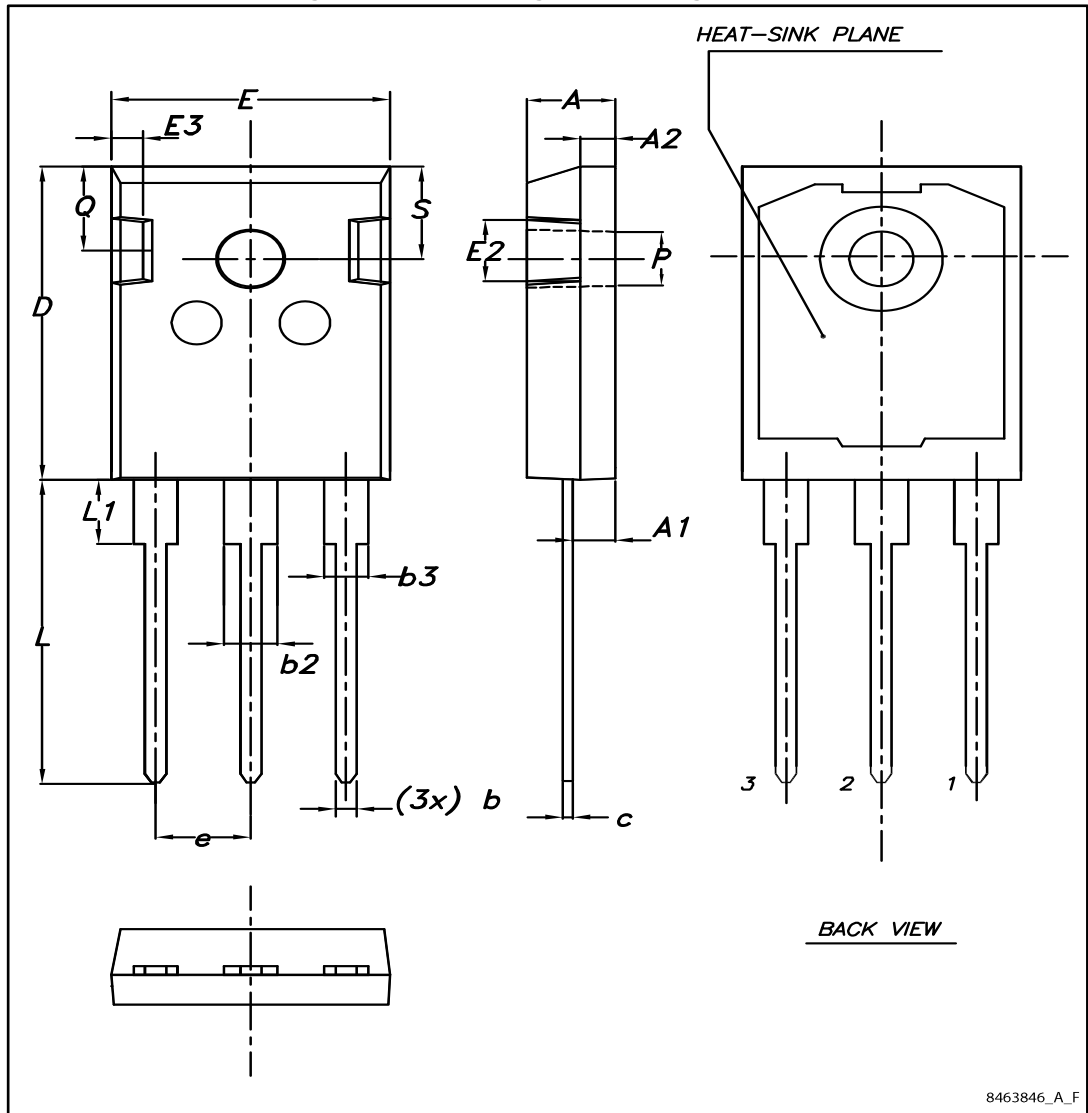

**STH12N120K5-2, STP12N120K5,  
STW12N120K5, STWA12N120K5**

**Package information**

**Table 12: TO-247 long leads mechanical data**

Dim.	mm.		
	Min.	Typ.	Max.
A	4.90	5.00	5.10
A1	2.31	2.41	2.51
A2	1.90	2.00	2.10
b	1.16		1.26
b2			3.25
b3			2.25
c	0.59		0.66
D	20.90	21.00	21.10
E	15.70	15.80	15.90
E2	4.90	5.00	5.10
E3	2.40	2.50	2.60
e	5.34	5.44	5.54
L	19.80	19.92	20.10
L1			4.30
P	3.50	3.60	3.70
Q	5.60		6.00
S	6.05	6.15	6.25

Revision history

STH12N120K5-2, STP12N120K5,  
 STW12N120K5, STWA12N120K5

## 5 Revision history

Table 13: Document revision history

Date	Revision	Changes
23-Aug-2011	1	First release.
17-Jan-2013	2	<ul style="list-style-type: none"> <li>Minor text changes</li> <li>Added: H<sup>2</sup>PAK package</li> <li>The part number STB12N120K5 has been moved to a separate datasheet</li> <li>Updated:</li> <li>Updated: mechanical data for TO-247 package</li> </ul>
16-May-2014	3	<ul style="list-style-type: none"> <li>The part numbers STFW12N120K5 has been moved to a separate datasheet</li> <li>Added: TO-247 long leads package</li> <li>Modified: I<sub>AR</sub>, E<sub>AS</sub>, dv/dt values in <a href="#">Table 2: "Absolute maximum ratings"</a></li> <li>Modified: the entire typical values in <a href="#">Table 5: "Dynamic"</a>, <a href="#">Table 6: "Switching times"</a> and <a href="#">Table 7: "Source drain diode"</a></li> <li>Added: <a href="#">Section 2.1: "Electrical characteristics (curves)"</a></li> <li>Minor text changes</li> </ul>
08-Apr-2015	4	<p>Updated title, silhouette and description in cover page.            Updated <a href="#">Table 4: "On/off states"</a>, <a href="#">Table 5: "Dynamic"</a>, <a href="#">Figure 9: "Static drain-source on-resistance"</a> and <a href="#">Figure 10: "Capacitance variations"</a>.</p> <p>Minor text change.</p>

**STH12N120K5-2, STP12N120K5, STW12N120K5,  
STWA12N120K5**

---

**IMPORTANT NOTICE – PLEASE READ CAREFULLY**

STMicroelectronics NV and its subsidiaries (“ST”) reserve the right to make changes, corrections, enhancements, modifications, and improvements to ST products and/or to this document at any time without notice. Purchasers should obtain the latest relevant information on ST products before placing orders. ST products are sold pursuant to ST’s terms and conditions of sale in place at the time of order acknowledgement.

Purchasers are solely responsible for the choice, selection, and use of ST products and ST assumes no liability for application assistance or the design of Purchasers’ products.

No license, express or implied, to any intellectual property right is granted by ST herein.

Resale of ST products with provisions different from the information set forth herein shall void any warranty granted by ST for such product.

ST and the ST logo are trademarks of ST. All other product or service names are the property of their respective owners.

Information in this document supersedes and replaces information previously supplied in any prior versions of this document.

© 2015 STMicroelectronics – All rights reserved