

Excellent Integrated System Limited

Stocking Distributor

Click to view price, real time Inventory, Delivery & Lifecycle Information:

[Newava Technology Inc.](#)
[S34568](#)

For any questions, you can email us directly:

sales@integrated-circuit.com

EP13 LM259X Inductor
33 uHy 3.60 ADC

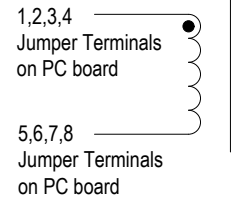
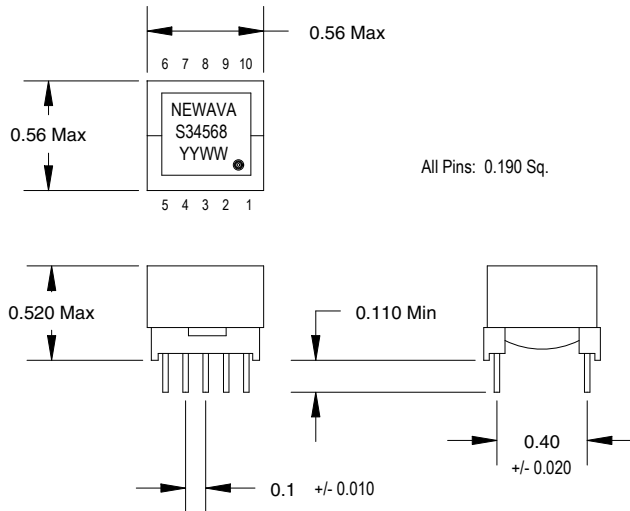

ELECTRICAL SPECS:

- 1: INDUCTANCE: @ 10 kHz, 0.1 Vrms
(1 thru 4 to 5 thru 8) = 33 - 42 uHy
- 2: DCRs:
(1 thru 4 to 5 thru 8) = 0.035 Ohms Max.
- 3: SRF: 2.0 MHz Min
- 4: HIPOT: 500 VDC
Winding to core (2 Sec., 5 mA Max)

All pins may not be used.
Specifications at room temperature of 25 C.

A	3/28/03		KAM	Production Release		
REV.	DATE	EON	BY	DESCRIPTION		
TOLERANCES ON				Newava Tech. Watertown, SD 57201 605-886-0264		
.XXX + -	.XX +	ANGLE + -	DATE		33 uHy Inductor 3.60 ADC	
DRAWN:			SCALE	MODEL		DRAWING NO.
CHECKED: -					S34568	A
APPROVED: -		- KAM	NEXT ASSY:			
THIS PRINT MUST NOT BE COPIED IN WHOLE OR IN PART				OR USED DETRIMENTALLY TO OUR INTEREST	SHEET 1 OF 1	