

Excellent Integrated System Limited

Stocking Distributor

Click to view price, real time Inventory, Delivery & Lifecycle Information:

[Texas Instruments](#)
[LM2781TP/NOPB](#)

For any questions, you can email us directly:

sales@integrated-circuit.com

LM2781 Ultra-Low Ripple Switched Capacitor Voltage Inverter

Check for Samples: [LM2781](#)

FEATURES

- Inverts Input Voltage
- Ultra-Low Voltage Ripple and 8Ω Typical Output Resistance with Two Flying Capacitors
- Output Resistance of 18Ω Using One Flying Capacitor
- 210kHz (typ.) Switching Frequency
- 8-pin DSBGA Package (1.4mm × 1.4mm × 0.5mm)

APPLICATIONS

- Cellular Phones
- Pagers
- PDAs
- Op-Amp Power Supplies
- Interface Power Supplies
- Handheld Instruments

Typical Application Circuit

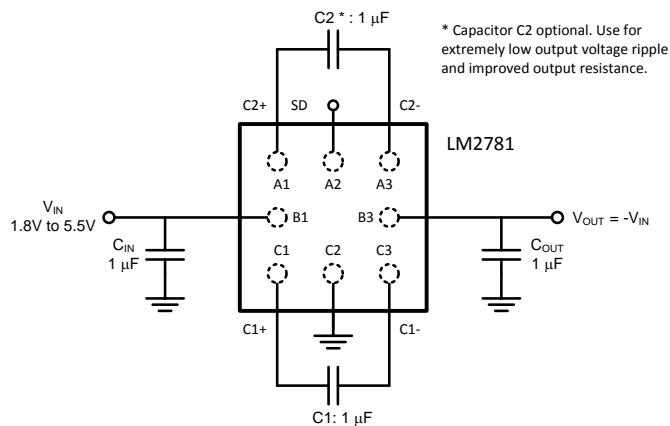

DESCRIPTION

The LM2781 is a charge pump that inverts an input voltage in the range of 1.8V to 5.5V to the corresponding output voltage of -1.8V to -5.5V. With use of three or four low-cost external ceramic capacitors, the LM2781 can provide up to 50mA of output current.

The LM2781 operates at a 210kHz typical switching frequency to minimize supply current (0.7mA typ.). Two charge pumps operate 180° out of phase to significantly reduce the output voltage ripple compared to that of traditional single-phase charge pump circuits. If larger output ripple can be tolerated, optional capacitor C2 may be omitted to reduce the cost and size of the solution. The LM2781 is available in an 8-pin DSBGA chip-scale package.

See also: LM2780, a slow clock (12kHz typ) version of this topology with extremely low supply current.



Please be aware that an important notice concerning availability, standard warranty, and use in critical applications of Texas Instruments semiconductor products and disclaimers thereto appears at the end of this data sheet.

All trademarks are the property of their respective owners.

LM2781

SNVS201B –MAY 2004–REVISED MAY 2004

www.ti.com

Connection Diagram

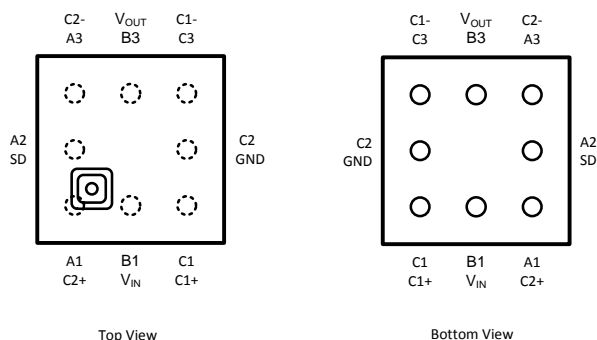

Figure 1. 8-Bump Thin DSBGA Package
 Package Number YPB0008

PIN DESCRIPTION

Pin	Name	Description
A1	C2+	Secondary flying-capacitor connection
B1	V _{IN}	Input voltage. Input range: 1.8V to 5.5V
C1	C1+	Primary flying-capacitor connection
A2	SD	Shutdown pin logic input. Low = on, High = shutdown
C2	GND	Ground
A3	C2-	Secondary flying-capacitor connection
B3	V _{OUT}	Output voltage. V _{OUT} = -V _{IN}
C3	C1-	Primary flying capacitor connection



These devices have limited built-in ESD protection. The leads should be shorted together or the device placed in conductive foam during storage or handling to prevent electrostatic damage to the MOS gates.

Absolute Maximum Ratings⁽¹⁾⁽²⁾

V _{IN} pin: Voltage to GND	-0.3V to 5.8V	
SD pin: Voltage to GND	-0.3V to (V _{IN} + 0.3V), with 5.8V max	
Output Short-to-GND Duration ⁽³⁾	1 sec.	
Maximum Junction Temperature (T _{J-MAX})	150°C	
Storage Temperature Range	-65°C to +150°C	
Pad Temperature (Soldering, 10 sec.)	265°C	
ESD Rating ⁽⁴⁾	Human-body model	2kV
	Machine model	200V

- (1) Absolute Maximum Ratings indicate limits beyond which damage to the component may occur. Operating Ratings are conditions under which operation of the device is ensured. Operating Ratings do not imply ensured performance limits. For ensured performance limits and associated test conditions, see the Electrical Characteristics table.
- (2) All voltages are with respect to the potential at the GND pin.
- (3) V_{OUT} may be shorted to GND for one second without damage when the ambient temperature is at or below 85°C. Prolonged or repeated shorts of V_{OUT} to GND may damage the device, and should be avoided.
- (4) The human-body model is a 100pF capacitor discharged through a 1.5kΩ resistor into each pin. The machine model is a 200pF capacitor discharged directly into each pin.

Operating Ratings^{(1) (2)}

- (1) Absolute Maximum Ratings indicate limits beyond which damage to the component may occur. Operating Ratings are conditions under which operation of the device is ensured. Operating Ratings do not imply ensured performance limits. For ensured performance limits and associated test conditions, see the Electrical Characteristics table.
- (2) All voltages are with respect to the potential at the GND pin.

Operating Ratings^{(1) (2)} (continued)

Input Voltage Range	1.8V to 5.5V
Junction Temperature (T _J) Range	-40°C to +90°C
Ambient Temperature (T _A) Range ⁽³⁾	-40°C to +85°C

- (3) Maximum ambient temperature (T_{A-MAX}) is dependent on the maximum operating junction temperature (T_{J-MAX-OP} = 90°C), the maximum power dissipation of the device in the application (P_{D-MAX}), and the junction-to-ambient thermal resistance of the part in the application (θ_{JA}), as given by the following equation: T_{A-MAX} = T_{J-MAX-OP} - (θ_{JA} × P_{D-MAX}).

Thermal Properties

Junction-to-Ambient Thermal Resistance (θ _{JA}) ⁽¹⁾	220°C/W
--	---------

- (1) Junction-to-ambient thermal resistance of the DSBGA package is highly application and board-layout dependent.

Electrical Characteristics⁽¹⁾⁽²⁾

Limits in standard typeface are for T_J = 25°C, and limits in **boldface** type apply over the full operating junction temperature range (-40°C ≤ T_J ≤ +90°C). Unless otherwise noted: specifications apply to the LM2781 Typical Application Circuit (pg. 1) with V_{IN} = 5.0V, V(SD) = 0V, and C_{IN} = C_{OUT} = C1 = C2 = 1μF.⁽³⁾

Symbol	Parameter	Conditions	Min	Typ	Max	Units
R _{OUT}	Output Resistance ⁽⁴⁾	I _{OUT} = 10mA, C2 = 1μF		8	30	Ω
		I _{OUT} = 10mA, C2 removed		18	40	Ω
I _Q	Supply Current	No load		0.7	1.4	mA
I _{SD}	Shutdown Supply Current	V(SD) = 5.0V		0.1	0.5	μA
F _{SW}	Switching Frequency		100	210	400	kHz
V _{SD}	Shutdown Pin Logic Levels	Normal Operation 1.8V ≤ V _{IN} ≤ 5.5V	0		0.5	V
		Shutdown Mode 1.8V ≤ V _{IN} ≤ 5.5V	0.5×V_{IN}		V_{IN}	
V _{OUTP-P}	Output Voltage Ripple	V _{IN} = 5.0V, I _{OUT} = 10mA		10		mV
P _{EFF}	Power Efficiency	V _{IN} = 5.0V, I _{OUT} = 10mA		92		%

- (1) All voltages are with respect to the potential at the GND pin.
 (2) Max and Min limits are specified by design, test, or statistical analysis. Typical numbers are not ensured, but do represent the most likely norm.
 (3) C_{IN}, C_{OUT}, C1, and C2: Low-ESR Surface-Mount Ceramic Capacitors (MLCCs) used in setting electrical characteristics.
 (4) Output resistance is a model for the voltage drop at the output, resulting from internal switch resistance, capacitor ESR, and charge pump charge transfer characteristics. Output voltage can be predicted with the following equation: V_{OUT} = -[V_{IN} - (I_{OUT} × R_{OUT})]

LM2781

SNVS201B –MAY 2004–REVISED MAY 2004

www.ti.com

Typical Performance Characteristics

Unless otherwise specified, $T_A = 25^\circ\text{C}$, $C_{IN} = C_{OUT} = C1 = C2 = 1\mu\text{F}$.

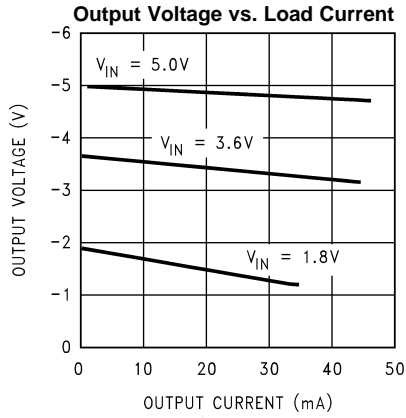

Figure 2.

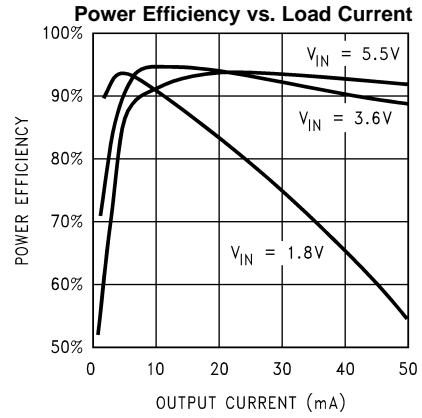

Figure 3.

Output Resistance vs. Temperature ($I_{OUT} = 10\text{mA}$)

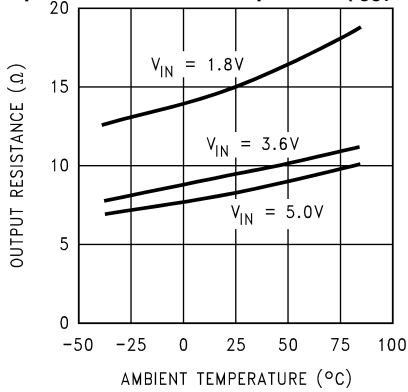

Figure 4.

Supply Current vs. Temperature ($I_{OUT} = 0$)

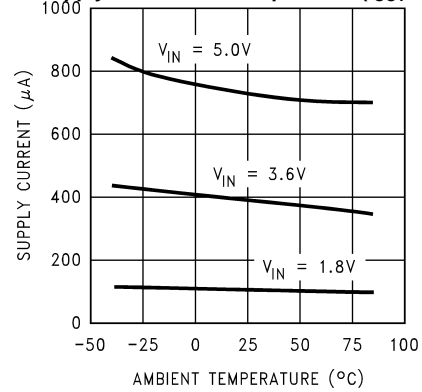

Figure 5.

Switching Frequency vs. Temperature

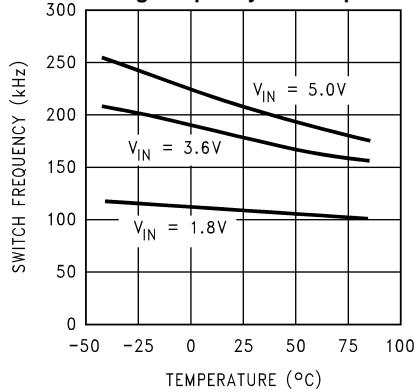

Figure 6.

Output Voltage Ripple vs. Output Current

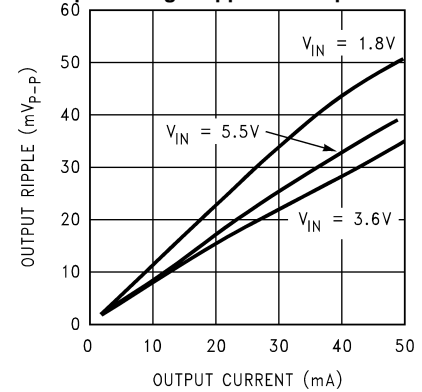
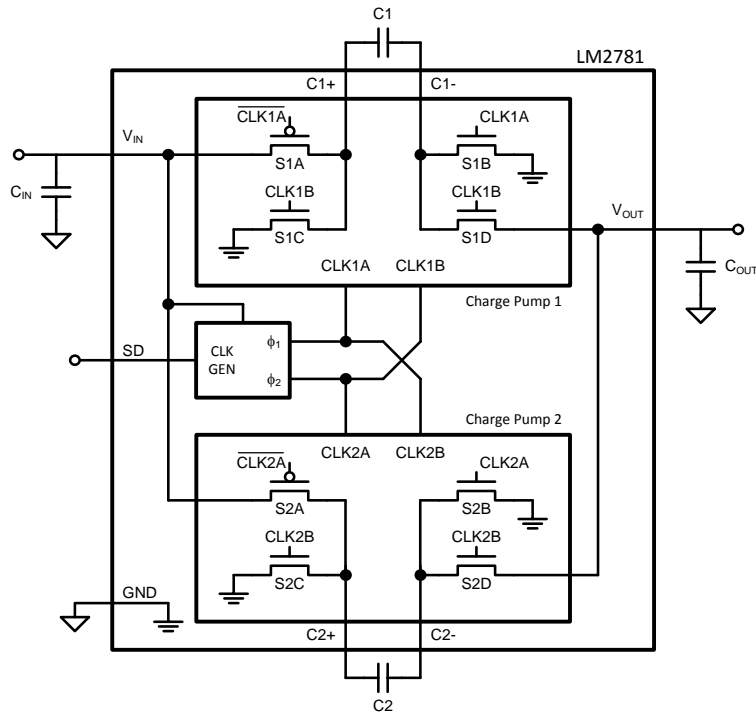

Figure 7.

Block Diagram



LM2781

SNVS201B –MAY 2004–REVISED MAY 2004

www.ti.com

OPERATION DESCRIPTION

The LM2781 is a switched capacitor voltage inverter that produces a negative output voltage from a positive input voltage. To minimize output voltage ripple, the LM2781 contains two charge pump inverters that operate 180° out of phase. These two charge pumps can be seen in the block diagram above.

A basic switched capacitor inverter is a two-phase charge pump circuit that transfers charge from the input to the output using a flying capacitor. Charge Pump 1 in the block diagram will be used to illustrate the operation of a single charge pump. Disregard Charge Pump 2 in the diagram for now. In phase 1 (ϕ_1), the CLK1A signal of Charge Pump 1 is high, and MOSFET switches S1A and S1B are ON. For Charge Pump 1, this is the charge phase, as the flying capacitor C1 is charged to the input voltage. In the second phase (ϕ_2), the positive-charged plate of C1 is connected to GND through switch S1C, and the negative-charged plate is connected to the output through switch S1D. This results in the output voltage being approximately equal in magnitude to the input voltage, but opposite in sign ($V_{OUT} \approx -V_{IN}$). In this pump phase, charge stored on the flying capacitor supplies the current to the load and transfers charge to the output capacitor.

This basic inverter has ripple in the output voltage. During the charge phase, the load current is supplied by the charge on the output capacitor. As charge is pulled off C_{OUT} , the voltage across the capacitor drops, and the magnitude of the output voltage ($|V_{OUT}|$) falls. During the pump phase, the flying capacitor transfers charge to the C_{OUT} , elevating both the voltage across the C_{OUT} and the magnitude of the output voltage.

The LM2781 contains two charge pump inverters running 180° out of phase. Notice in the block diagram that the clock connections on Charge Pump 2 are opposite of the clock connections to Charge Pump 1. Thus, when Charge Pump 1 is in the charge phase, Charge Pump 2 is in the pump phase, and vice-versa. With this double-pump technology, there is always a flying capacitor connected to the output. This results in significantly lower output voltage ripple than that of a single-pump inverter.

OUTPUT VOLTAGE RIPPLE

Several factors influence the magnitude of voltage ripple on the output of the LM2781. Primary influences are output capacitance, flying capacitance, load current, input voltage, and output capacitor ESR.

The magnitude of the output voltage ripple is difficult to predict with equations when the LM2781 is double pumping. Refer to the Typical Performance Characteristic curves for this information. In general, ripple decreases with increased output capacitance, decreased load current, a lower input voltage, a smaller flying capacitance and/or a smaller output capacitor ESR.

When only one charge pump is active (C2 removed), the output ripple is more predictable, and can be estimated with the following equation:

$$V_{RIPPLE} = [(0.5 \times I_{OUT}) / (f_{SW} \times C_{OUT})] + (2 \times I_{OUT} \times ESR_{C_{out}})$$

OUTPUT RESISTANCE

Output resistance (R_{OUT}) models the internal non-idealities of a charge pump that result in droop in the output voltage. The effect of output resistance on output voltage is expressed in the following equation:

$$V_{OUT} = -[V_{IN} - (|I_{OUT}| \times R_{OUT})]$$

Output resistance is a function of the internal switch resistance (R_{SW}), flying capacitance (C1), flying capacitor equivalent series resistance (ESR_{C1}), output capacitor ESR ($ESR_{C_{out}}$), and internal switching frequency (f_{SW}). When the LM2781 operates as a single charge pump (C2 removed), the output resistance can be approximated by the following equation:

$$1 \text{ Fly Cap: } R_{OUT1} \approx 2R_{SW1} + [1/(f_{SW} \times C1)] + 4ESR_{C1} + ESR_{C_{out}}$$

R_{SW1} is the sum of the ON resistance of the four internal MOSFET switches of Charge Pump 1.

With both C1 and C2 in place, the double pumping topology of the LM2781 cuts the output resistance in half:

$$2 \text{ Fly Caps: } R_{OUT2} \approx 0.5 \times R_{OUT1}$$

Recommendations for minimizing output resistance include increasing flying capacitance and minimizing output and flying capacitor ESR.

CAPACITOR SELECTION

Surface-mount multi-layer ceramic capacitors are recommended for use with the LM2781. These capacitors are small, inexpensive and have very low equivalent series resistance (ESR, < 15mΩ typ.). Tantalum capacitors, OS-CON capacitors, and aluminum electrolytic capacitors generally are not recommended for use with the LM2781 due to their high ESR, as compared to ceramic capacitors.

For most applications, ceramic capacitors with X7R or X5R temperature characteristic are preferred for use with the LM2781. These capacitors have tight capacitance tolerance (as good as ±10%), hold their value over temperature (X7R: ±15% over -55°C to 125°C; X5R: ±15% over -55°C to 85°C), and typically have little voltage coefficient.

Capacitors with Y5V and/or Z5U temperature characteristic are generally not recommended for use with the LM2781. These types of capacitors typically have wide capacitance tolerance (+80%, -20%), vary significantly over temperature (Y5V: +22%, -82% over -30°C to +85°C range; Z5U: +22%, -56% over +10°C to +85°C range), and have poor voltage coefficients. Under some conditions, a nominal 1μF Y5V or Z5U capacitor could have a capacitance of only 0.1μF. Such deviation would severely affect performance of the LM2781 circuit.

IMPORTANT NOTICE

Texas Instruments Incorporated and its subsidiaries (TI) reserve the right to make corrections, enhancements, improvements and other changes to its semiconductor products and services per JESD46, latest issue, and to discontinue any product or service per JESD48, latest issue. Buyers should obtain the latest relevant information before placing orders and should verify that such information is current and complete. All semiconductor products (also referred to herein as "components") are sold subject to TI's terms and conditions of sale supplied at the time of order acknowledgment.

TI warrants performance of its components to the specifications applicable at the time of sale, in accordance with the warranty in TI's terms and conditions of sale of semiconductor products. Testing and other quality control techniques are used to the extent TI deems necessary to support this warranty. Except where mandated by applicable law, testing of all parameters of each component is not necessarily performed.

TI assumes no liability for applications assistance or the design of Buyers' products. Buyers are responsible for their products and applications using TI components. To minimize the risks associated with Buyers' products and applications, Buyers should provide adequate design and operating safeguards.

TI does not warrant or represent that any license, either express or implied, is granted under any patent right, copyright, mask work right, or other intellectual property right relating to any combination, machine, or process in which TI components or services are used. Information published by TI regarding third-party products or services does not constitute a license to use such products or services or a warranty or endorsement thereof. Use of such information may require a license from a third party under the patents or other intellectual property of the third party, or a license from TI under the patents or other intellectual property of TI.

Reproduction of significant portions of TI information in TI data books or data sheets is permissible only if reproduction is without alteration and is accompanied by all associated warranties, conditions, limitations, and notices. TI is not responsible or liable for such altered documentation. Information of third parties may be subject to additional restrictions.

Resale of TI components or services with statements different from or beyond the parameters stated by TI for that component or service voids all express and any implied warranties for the associated TI component or service and is an unfair and deceptive business practice. TI is not responsible or liable for any such statements.

Buyer acknowledges and agrees that it is solely responsible for compliance with all legal, regulatory and safety-related requirements concerning its products, and any use of TI components in its applications, notwithstanding any applications-related information or support that may be provided by TI. Buyer represents and agrees that it has all the necessary expertise to create and implement safeguards which anticipate dangerous consequences of failures, monitor failures and their consequences, lessen the likelihood of failures that might cause harm and take appropriate remedial actions. Buyer will fully indemnify TI and its representatives against any damages arising out of the use of any TI components in safety-critical applications.

In some cases, TI components may be promoted specifically to facilitate safety-related applications. With such components, TI's goal is to help enable customers to design and create their own end-product solutions that meet applicable functional safety standards and requirements. Nonetheless, such components are subject to these terms.

No TI components are authorized for use in FDA Class III (or similar life-critical medical equipment) unless authorized officers of the parties have executed a special agreement specifically governing such use.

Only those TI components which TI has specifically designated as military grade or "enhanced plastic" are designed and intended for use in military/aerospace applications or environments. Buyer acknowledges and agrees that any military or aerospace use of TI components which have **not** been so designated is solely at the Buyer's risk, and that Buyer is solely responsible for compliance with all legal and regulatory requirements in connection with such use.

TI has specifically designated certain components as meeting ISO/TS16949 requirements, mainly for automotive use. In any case of use of non-designated products, TI will not be responsible for any failure to meet ISO/TS16949.

Products

Audio	www.ti.com/audio
Amplifiers	amplifier.ti.com
Data Converters	dataconverter.ti.com
DLP® Products	www.dlp.com
DSP	dsp.ti.com
Clocks and Timers	www.ti.com/clocks
Interface	interface.ti.com
Logic	logic.ti.com
Power Mgmt	power.ti.com
Microcontrollers	microcontroller.ti.com
RFID	www.ti-rfid.com
OMAP Applications Processors	www.ti.com/omap
Wireless Connectivity	www.ti.com/wirelessconnectivity

Applications

Automotive and Transportation	www.ti.com/automotive
Communications and Telecom	www.ti.com/communications
Computers and Peripherals	www.ti.com/computers
Consumer Electronics	www.ti.com/consumer-apps
Energy and Lighting	www.ti.com/energy
Industrial	www.ti.com/industrial
Medical	www.ti.com/medical
Security	www.ti.com/security
Space, Avionics and Defense	www.ti.com/space-avionics-defense
Video and Imaging	www.ti.com/video

TI E2E Community

	e2e.ti.com
--	--