

Excellent Integrated System Limited

Stocking Distributor

Click to view price, real time Inventory, Delivery & Lifecycle Information:

[Laird Technologies - Signal Integrity Products](#)
[HI0805R800R-01](#)

For any questions, you can email us directly:

sales@integrated-circuit.com

Steward

Advanced Ferrite Materials, EMI Suppression, and Inductive Products

Home • Ferrite Product Lines • New Products • Technical • General • Contact • Steward Sales

HI0805R800R-01

STEWARD PART NUMBERING SYSTEM					
28	F	0121	- 0	S	R
MATERIAL TYPE	PRODUCT CODE	PART SIZE CODE	SELECTED DIMENSION CODE	ADDITIONAL DESCRIPTION	PACKAGING CODE

Ambient Operating Temperature Range : -55°C to + 125°C

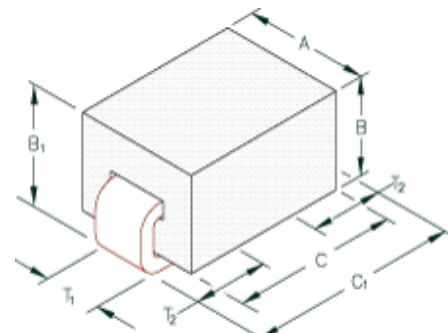

Figure #1

STEWARD PART NUMBERING SYSTEM					
DM	3312	X	101	R	(10 Pb Free) - 00
PRODUCT SERIES CODE	PART SIZE CODE	RATED CURRENT CODE	IMPEDANCE VALUE CODE	PACKAGING CODE	ADDITIONAL DESCRIPTION

Ambient Operating Temperature Range : -55°C to + 125°C

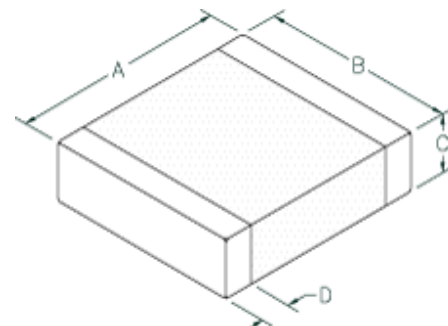

Figure #2

Drawing Figure

Figure Number
2

Electrical Characteristics

NET Z @ 100 MHz	DCR Max	Rated Current mA
--------------------	------------	---------------------

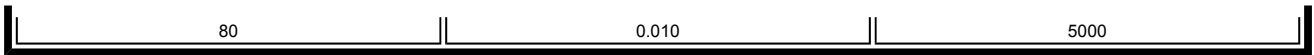

Physical Dimensions

A mm	B mm	B1 mm	C mm	C1 mm	D mm	A in	B in	B1 in	C in	C1 in	D in
2.00	1.25	-	0.90	-	0.51	0.079	0.049	-	0.035	-	0.020

Wire Dimensions

T1 mm	T2 mm	T1 in	T2 in
-	-	-	-

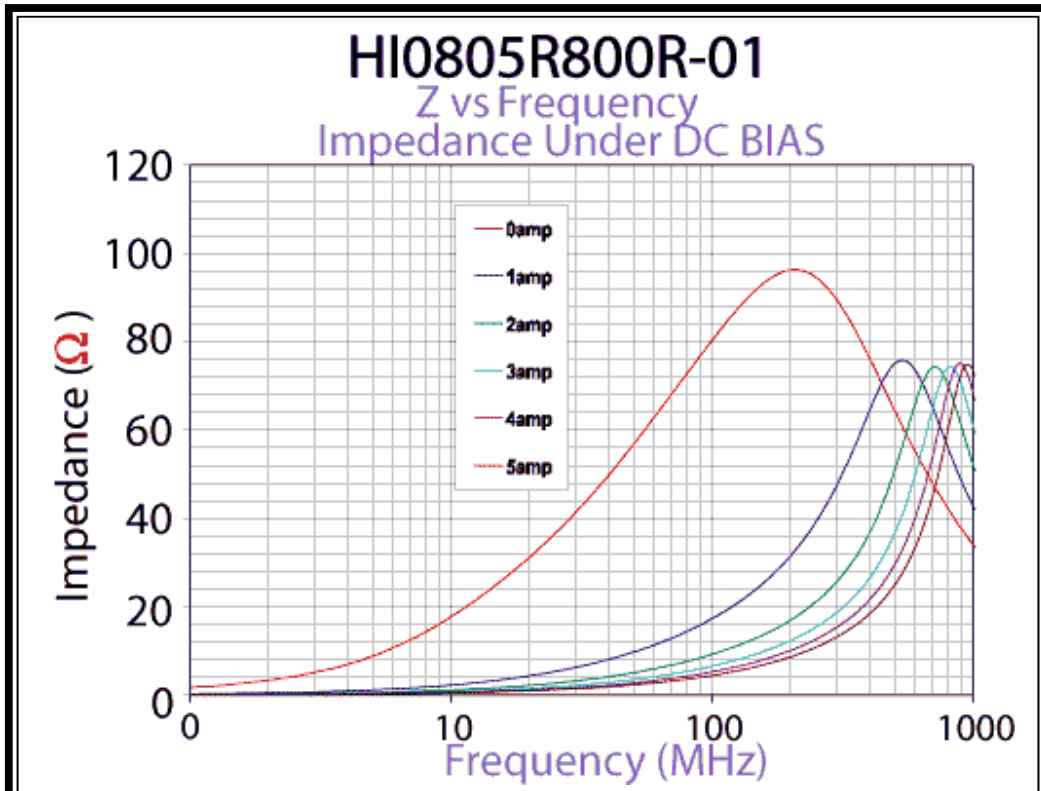

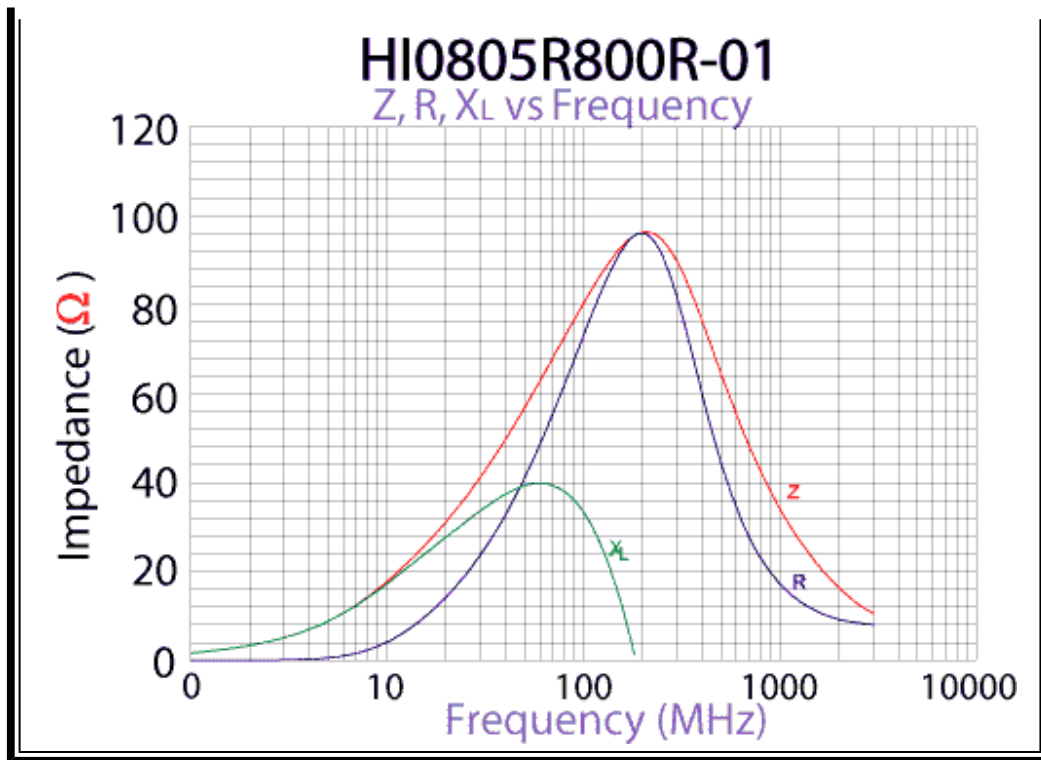

Specifications, which provide more details for the correct use of the described products, are available upon request. All specifications are subject to change without notice. For more information on any of the products listed above, please contact Steward customer service department at (800) 634-2673.

americas@steward.com mexico@steward.com europe@steward.com asia@steward.com

Copyright© 2004 Steward, Inc.

Last Updated: 2/19/2004