

## Excellent Integrated System Limited

Stocking Distributor

Click to view price, real time Inventory, Delivery & Lifecycle Information:

[STMicroelectronics](#)  
[M74HC51B1R](#)

For any questions, you can email us directly:

[sales@integrated-circuit.com](mailto:sales@integrated-circuit.com)



# M74HC51

## DUAL 2 WIDE 2 INPUT AND/OR INVERT GATE

- **HIGH SPEED:**  
 $t_{PD} = 11\text{ns}$  (TYP.) at  $V_{CC} = 6\text{V}$
- **LOW POWER DISSIPATION:**  
 $I_{CC} = 1\mu\text{A}$ (MAX.) at  $T_A=25^\circ\text{C}$
- **HIGH NOISE IMMUNITY:**  
 $V_{NIH} = V_{NIL} = 28\%$   $V_{CC}$  (MIN.)
- **SYMMETRICAL OUTPUT IMPEDANCE:**  
 $|I_{OH}| = I_{OL} = 4\text{mA}$  (MIN)
- **BALANCED PROPAGATION DELAYS:**  
 $t_{PLH} \approx t_{PHL}$
- **WIDE OPERATING VOLTAGE RANGE:**  
 $V_{CC}$  (OPR) = 2V to 6V
- **PIN AND FUNCTION COMPATIBLE WITH**  
 74 SERIES 51

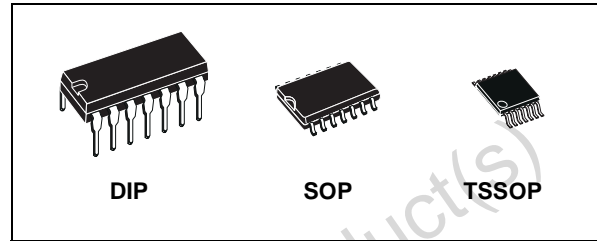

### ORDER CODES

PACKAGE	TUBE	T & R
DIP	M74HC51B1R	
SOP	M74HC51M1R	M74HC51RM13TR
TSSOP		M74HC51TTR

### DESCRIPTION

The M74HC51 is an high speed CMOS DUAL 2 WIDE 2 INPUT AND/OR INVERT GATE fabricated with silicon gate C<sup>2</sup>MOS technology. It contains a 2-WIDE 2-INPUT AND/OR INVERT GATE and a 2-WIDE 3-INPUT AND/OR INVERT GATE.

The internal circuit is composed of 3 stages (2 INPUT) or 5 stages (3 INPUT) including buffer output, which enables high noise immunity and stable output.

All inputs are equipped with protection circuits against static discharge and transient excess voltage.

### PIN CONNECTION AND IEC LOGIC SYMBOLS

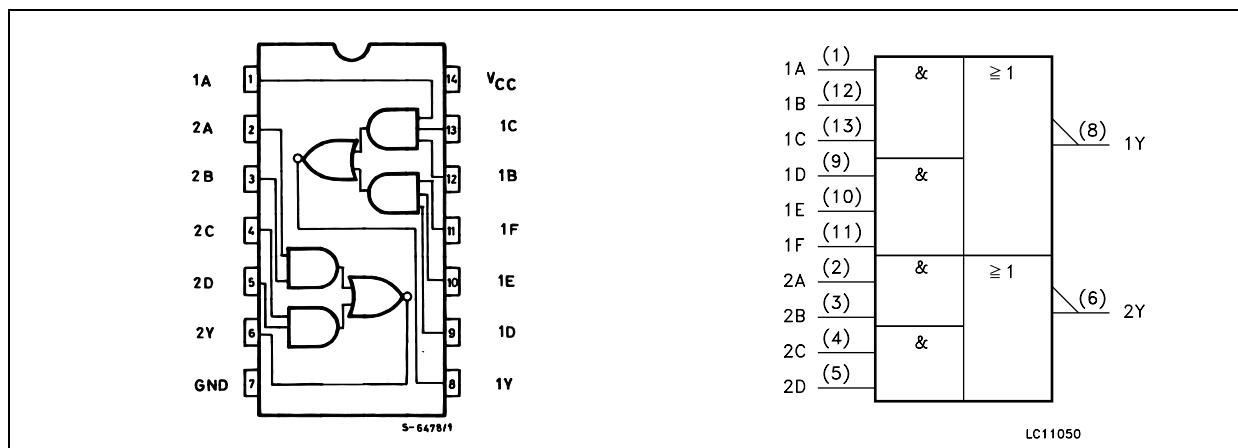

## M74HC51

### INPUT AND OUTPUT EQUIVALENT CIRCUIT

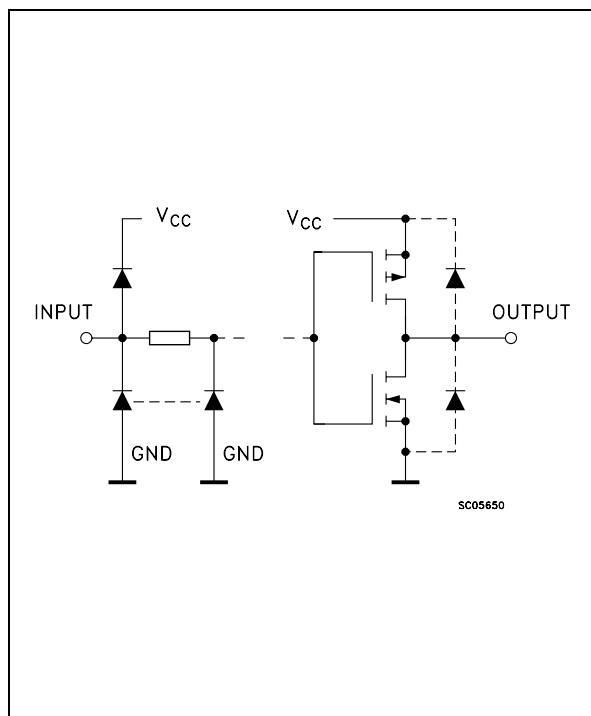

### PIN DESCRIPTION

PIN No	SYMBOL	NAME AND FUNCTION
1, 12, 13, 9, 10, 11	1A to 1F	Data Inputs
2, 3, 4, 5	2A to 2D	Data Inputs
8, 6	1Y to 2Y	Data Outputs
7	GND	Ground (0V)
14	V <sub>CC</sub>	Positive Supply Voltage

### TRUTH TABLE

1A	1B	1C	1D	1E	1F	1Y
H	H	H	X	X	X	L
X	X	X	H	H	H	L
ALL OTHER COMBINATIONS						H

### TRUTH TABLE

2A	2B	2C	2D	2Y
H	H	X	X	L
X	X	H	H	L
ALL OTHER COMBINATIONS				H

X : Don't Care

### ABSOLUTE MAXIMUM RATINGS

Symbol	Parameter	Value	Unit
V <sub>CC</sub>	Supply Voltage	-0.5 to +7	V
V <sub>I</sub>	DC Input Voltage	-0.5 to V <sub>CC</sub> + 0.5	V
V <sub>O</sub>	DC Output Voltage	-0.5 to V <sub>CC</sub> + 0.5	V
I <sub>IK</sub>	DC Input Diode Current	± 20	mA
I <sub>OK</sub>	DC Output Diode Current	± 20	mA
I <sub>O</sub>	DC Output Current	± 25	mA
I <sub>CC</sub> or I <sub>GND</sub>	DC V <sub>CC</sub> or Ground Current	± 50	mA
P <sub>D</sub>	Power Dissipation	500(*)	mW
T <sub>stg</sub>	Storage Temperature	-65 to +150	°C
T <sub>L</sub>	Lead Temperature (10 sec)	300	°C

Absolute Maximum Ratings are those values beyond which damage to the device may occur. Functional operation under these conditions is not implied

(\*) 500mW at 65 °C; derate to 300mW by 10mW/°C from 65°C to 85°C

## M74HC51

### RECOMMENDED OPERATING CONDITIONS

Symbol	Parameter	Value	Unit	
$V_{CC}$	Supply Voltage	2 to 6	V	
$V_I$	Input Voltage	0 to $V_{CC}$	V	
$V_O$	Output Voltage	0 to $V_{CC}$	V	
$T_{op}$	Operating Temperature	-55 to 125	°C	
$t_r, t_f$	Input Rise and Fall Time	$V_{CC} = 2.0V$	0 to 1000	ns
		$V_{CC} = 4.5V$	0 to 500	ns
		$V_{CC} = 6.0V$	0 to 400	ns

### DC SPECIFICATIONS

Symbol	Parameter	Test Condition		Value						Unit	
		$V_{CC}$ (V)		$T_A = 25^\circ C$			$-40 \text{ to } 85^\circ C$		$-55 \text{ to } 125^\circ C$		
				Min.	Typ.	Max.	Min.	Max.	Min.		Max.
$V_{IH}$	High Level Input Voltage	2.0		1.5			1.5		1.5		V
		4.5		3.15			3.15		3.15		
		6.0		4.2			4.2		4.2		
$V_{IL}$	Low Level Input Voltage	2.0				0.5		0.5		0.5	V
		4.5				1.35		1.35		1.35	
		6.0				1.8		1.8		1.8	
$V_{OH}$	High Level Output Voltage	2.0	$I_O = -20 \mu A$	1.9	2.0		1.9		1.9		V
		4.5	$I_O = -20 \mu A$	4.4	4.5		4.4		4.4		
		6.0	$I_O = -20 \mu A$	5.9	6.0		5.9		5.9		
		4.5	$I_O = -4.0 \text{ mA}$	4.18	4.31		4.13		4.10		
		6.0	$I_O = -5.2 \text{ mA}$	5.68	5.8		5.63		5.60		
$V_{OL}$	Low Level Output Voltage	2.0	$I_O = 20 \mu A$		0.0	0.1		0.1		0.1	V
		4.5	$I_O = 20 \mu A$		0.0	0.1		0.1		0.1	
		6.0	$I_O = 20 \mu A$		0.0	0.1		0.1		0.1	
		4.5	$I_O = 4.0 \text{ mA}$		0.17	0.26		0.33		0.40	
		6.0	$I_O = 5.2 \text{ mA}$		0.18	0.26		0.33		0.40	
$I_I$	Input Leakage Current	6.0	$V_I = V_{CC} \text{ or GND}$			$\pm 0.1$		$\pm 1$		$\pm 1$	$\mu A$
$I_{CC}$	Quiescent Supply Current	6.0	$V_I = V_{CC} \text{ or GND}$			1		10		20	$\mu A$

## M74HC51

### AC ELECTRICAL CHARACTERISTICS ( $C_L = 50 \text{ pF}$ , Input $t_r = t_f = 6 \text{ ns}$ )

Symbol	Parameter	Test Condition		Value						Unit	
		$V_{CC}$ (V)		$T_A = 25^\circ\text{C}$			$-40 \text{ to } 85^\circ\text{C}$		$-55 \text{ to } 125^\circ\text{C}$		
				Min.	Typ.	Max.	Min.	Max.	Min.		Max.
$t_{TLH}$ $t_{THL}$	Output Transition Time	2.0			30	75		95		110	ns
		4.5			8	15		19		22	
		6.0			7	13		16		19	
$t_{PLH}$ $t_{PHL}$	Propagation Delay Time	2.0			39	100		125		150	ns
		4.5			13	20		25		30	
		6.0			11	17		21		26	

### CAPACITIVE CHARACTERISTICS

Symbol	Parameter	Test Condition		Value						Unit	
		$V_{CC}$ (V)		$T_A = 25^\circ\text{C}$			$-40 \text{ to } 85^\circ\text{C}$		$-55 \text{ to } 125^\circ\text{C}$		
				Min.	Typ.	Max.	Min.	Max.	Min.		Max.
$C_{IN}$	Input Capacitance	5.0			5	10		10		10	pF
$C_{PD}$	Power Dissipation Capacitance (note 1)	5.0			32						pF

1)  $C_{PD}$  is defined as the value of the IC's internal equivalent capacitance which is calculated from the operating current consumption without load. (Refer to Test Circuit). Average operating current can be obtained by the following equation.  $I_{CC(opr)} = C_{PD} \times V_{CC} \times f_{IN} + I_{CC}$

### TEST CIRCUIT

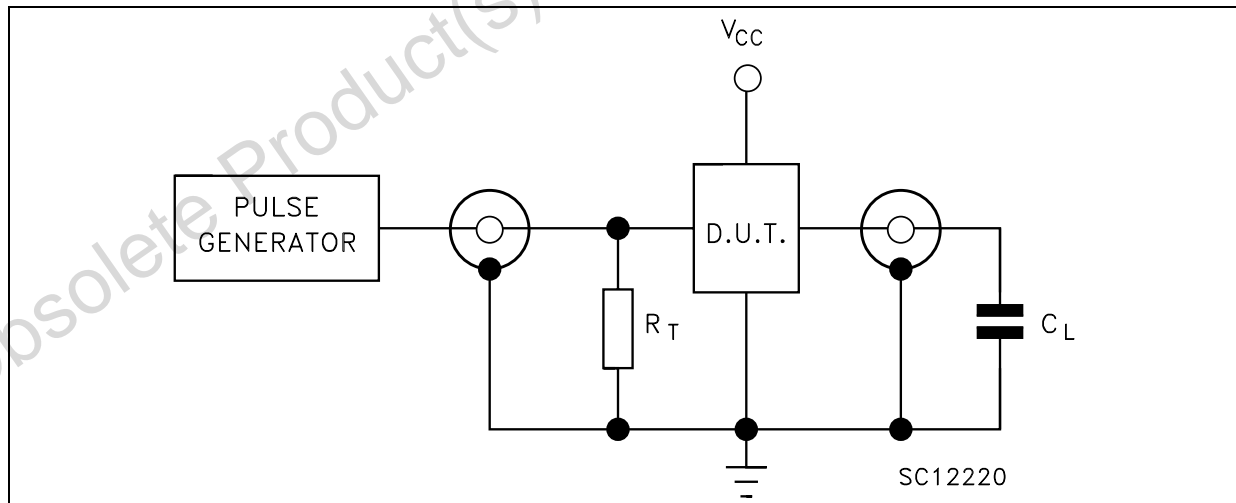

$C_L = 50 \text{ pF}$  or equivalent (includes jig and probe capacitance)  
 $R_T = Z_{OUT}$  of pulse generator (typically  $50 \Omega$ )

WAVEFORM : PROPAGATION DELAY TIMES (f=1MHz; 50% duty cycle)

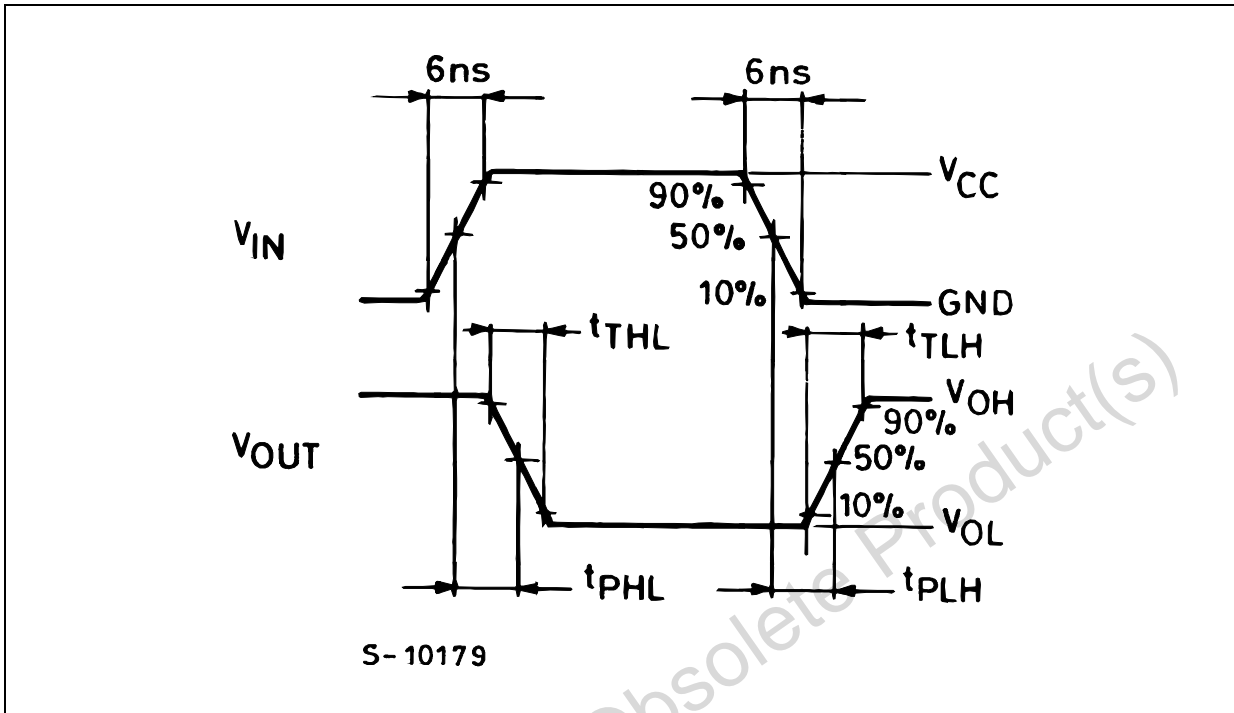

**M74HC51**

**Plastic DIP-14 MECHANICAL DATA**

DIM.	mm.			inch		
	MIN.	TYP	MAX.	MIN.	TYP.	MAX.
a1	0.51			0.020		
B	1.39		1.65	0.055		0.065
b		0.5			0.020	
b1		0.25			0.010	
D			20			0.787
E		8.5			0.335	
e		2.54			0.100	
e3		15.24			0.600	
F			7.1			0.280
l			5.1			0.201
L		3.3			0.130	
Z	1.27		2.54	0.050		0.100

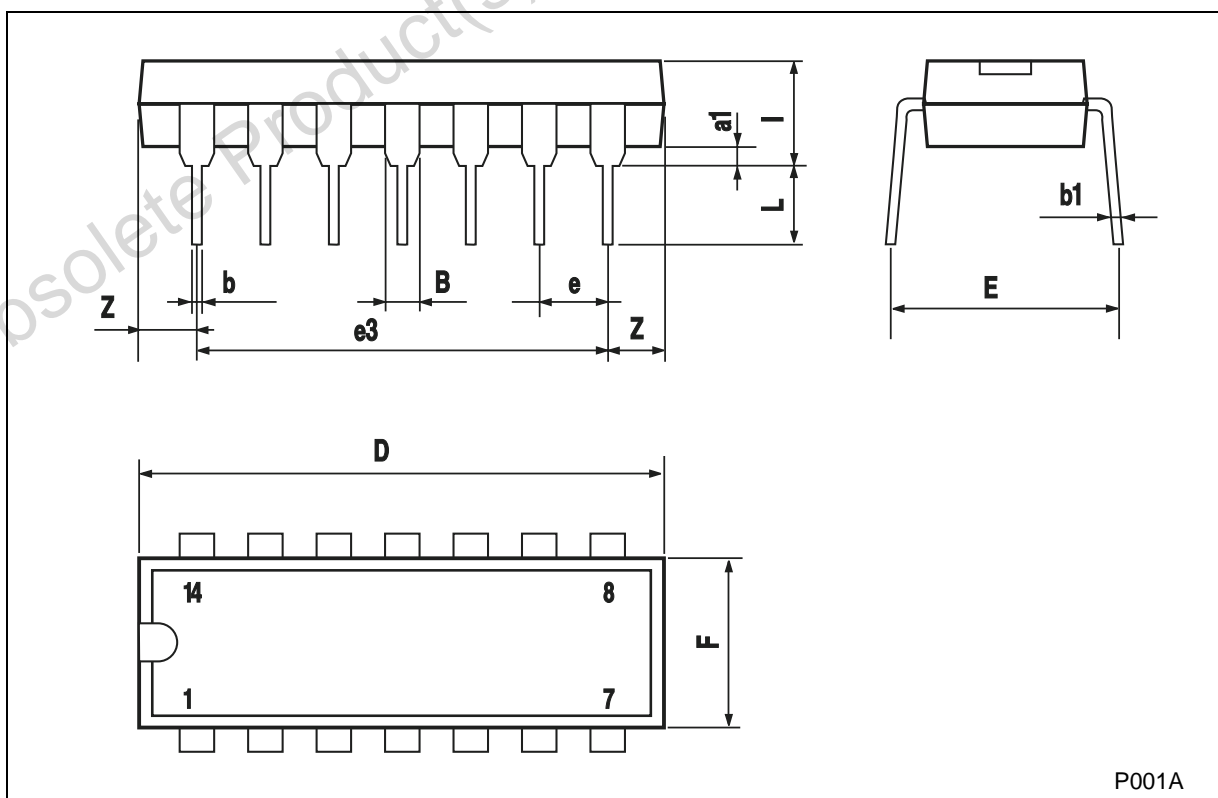

**M74HC51**

**SO-14 MECHANICAL DATA**

DIM.	mm.			inch		
	MIN.	TYP	MAX.	MIN.	TYP.	MAX.
A			1.75			0.068
a1	0.1		0.2	0.003		0.007
a2			1.65			0.064
b	0.35		0.46	0.013		0.018
b1	0.19		0.25	0.007		0.010
C		0.5			0.019	
c1	45° (typ.)					
D	8.55		8.75	0.336		0.344
E	5.8		6.2	0.228		0.244
e		1.27			0.050	
e3		7.62			0.300	
F	3.8		4.0	0.149		0.157
G	4.6		5.3	0.181		0.208
L	0.5		1.27	0.019		0.050
M			0.68			0.026
S	8° (max.)					

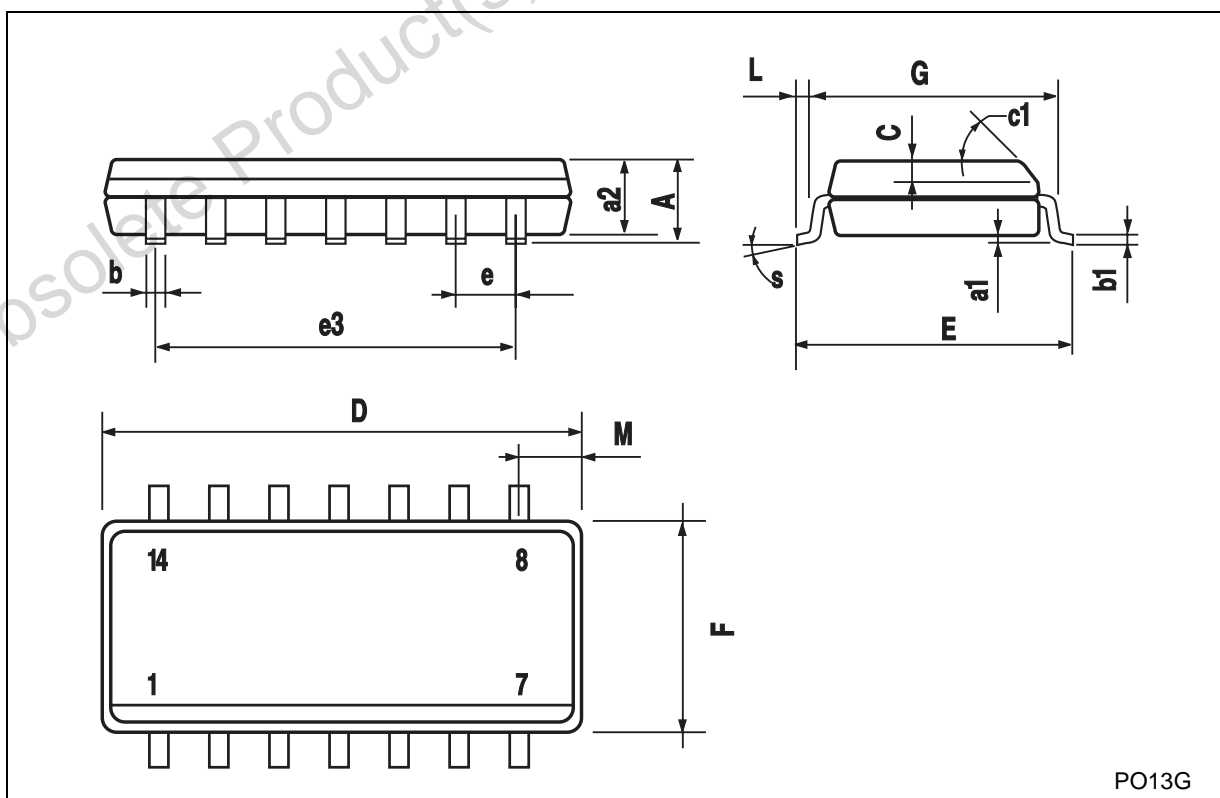

PO13G



**M74HC51**

**TSSOP14 MECHANICAL DATA**

DIM.	mm.			inch		
	MIN.	TYP	MAX.	MIN.	TYP.	MAX.
A			1.2			0.047
A1	0.05		0.15	0.002	0.004	0.006
A2	0.8	1	1.05	0.031	0.039	0.041
b	0.19		0.30	0.007		0.012
c	0.09		0.20	0.004		0.0089
D	4.9	5	5.1	0.193	0.197	0.201
E	6.2	6.4	6.6	0.244	0.252	0.260
E1	4.3	4.4	4.48	0.169	0.173	0.176
e		0.65 BSC			0.0256 BSC	
K	0°		8°	0°		8°
L	0.45	0.60	0.75	0.018	0.024	0.030

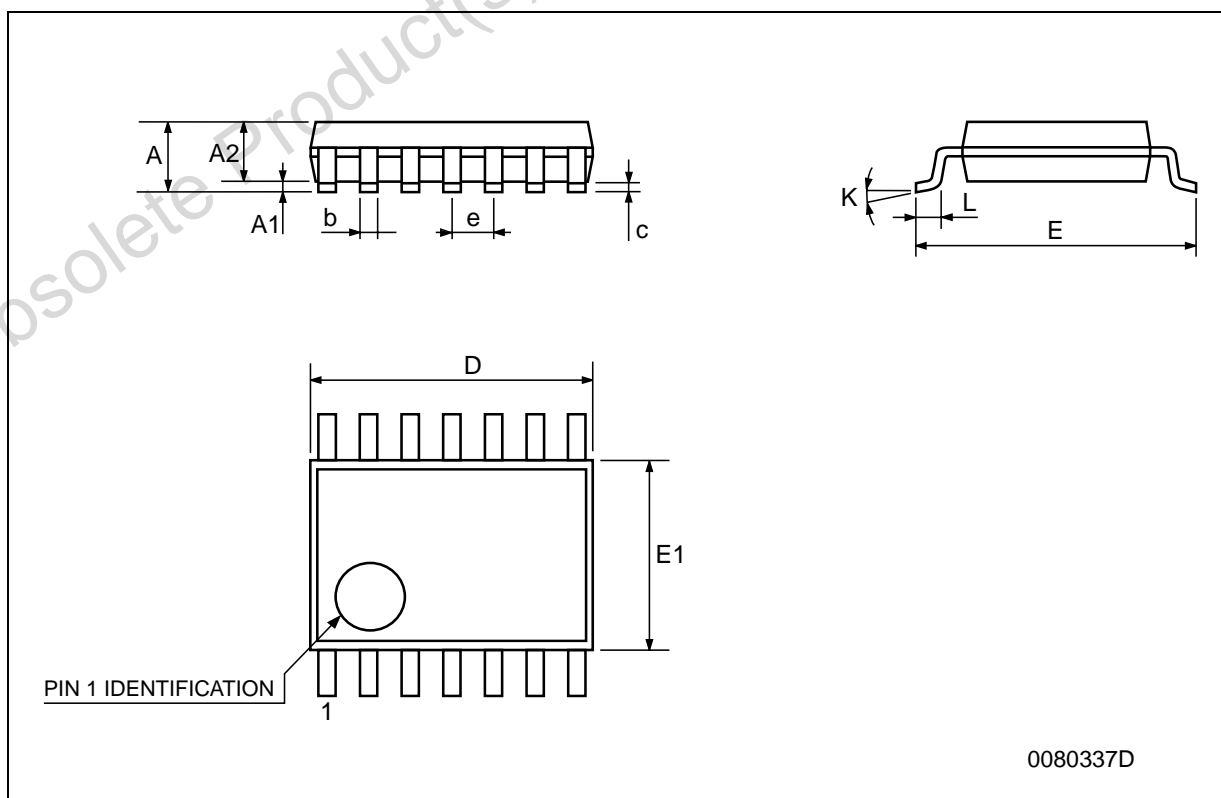

**M74HC51**

---

Obsolete Product(s) - Obsolete Product(s)

Information furnished is believed to be accurate and reliable. However, STMicroelectronics assumes no responsibility for the consequences of use of such information nor for any infringement of patents or other rights of third parties which may result from its use. No license is granted by implication or otherwise under any patent or patent rights of STMicroelectronics. Specifications mentioned in this publication are subject to change without notice. This publication supersedes and replaces all information previously supplied. STMicroelectronics products are not authorized for use as critical components in life support devices or systems without express written approval of STMicroelectronics.

© The ST logo is a registered trademark of STMicroelectronics

© 2001 STMicroelectronics - Printed in Italy - All Rights Reserved  
STMicroelectronics GROUP OF COMPANIES

Australia - Brazil - China - Finland - France - Germany - Hong Kong - India - Italy - Japan - Malaysia - Malta - Morocco  
Singapore - Spain - Sweden - Switzerland - United Kingdom

© <http://www.st.com>