

Excellent Integrated System Limited

Stocking Distributor

Click to view price, real time Inventory, Delivery & Lifecycle Information:

[ON Semiconductor](#)
[TCA0372DP1](#)

For any questions, you can email us directly:

sales@integrated-circuit.com

TCA0372, TCA0372B

1.0 A Output Current, Dual Power Operational Amplifiers

The TCA0372 is a monolithic circuit intended for use as a power operational amplifier in a wide range of applications, including servo amplifiers and power supplies. No deadband crossover distortion provides better performance for driving coils.

Features

- Output Current to 1.0 A
- Slew Rate of 1.3 V/ μ s
- Wide Bandwidth of 1.1 MHz
- Internal Thermal Shutdown
- Single or Split Supply Operation
- Excellent Gain and Phase Margins
- Common Mode Input Includes Ground
- Zero Deadband Crossover Distortion
- Pb-Free Packages are Available*



ON Semiconductor[®]

<http://onsemi.com>

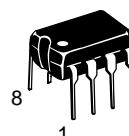

PDIP-8
DP1 SUFFIX
CASE 626

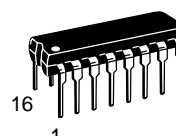

PDIP-16
DP2 SUFFIX
CASE 648

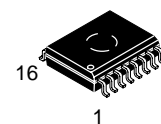

SOIC-16W
DW SUFFIX
CASE 751G

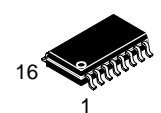

SOEIAJ-16
DM2 SUFFIX
CASE 966

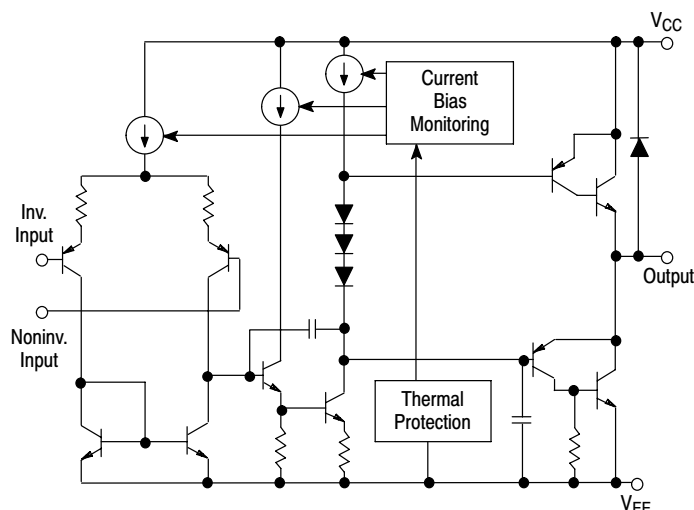

Figure 1. Representative Block Diagram

ORDERING INFORMATION

See detailed ordering and shipping information in the package dimensions section on page 6 of this data sheet.

DEVICE MARKING INFORMATION

See general marking information in the device marking section on page 6 of this data sheet.

*For additional information on our Pb-Free strategy and soldering details, please download the ON Semiconductor Soldering and Mounting Techniques Reference Manual, SOLDERRM/D.

TCA0372, TCA0372B

MAXIMUM RATINGS

Rating	Symbol	Value	Unit
Supply Voltage (from V_{CC} to V_{EE})	V_S	40	V
Input Differential Voltage Range	V_{IDR}	Note 1	V
Input Voltage Range	V_{IR}	Note 1	V
Junction Temperature (Note 2)	T_J	+150	°C
Operating Temperature Range	T_A	-40 to +125	°C
Storage Temperature Range	T_{stg}	-55 to +150	°C
DC Output Current	I_O	1.0	A
Peak Output Current (Nonrepetitive)	$I_{(max)}$	1.5	A
Thermal Resistance, Junction-to-Air Case 626 Case 648 Case 751G	$R_{\theta JA}$	137 72 80	°C/W
Thermal Resistance, Junction-to-Case Case 626 Case 648 Case 751G	$R_{\theta JC}$	23 10 12	°C/W

Maximum ratings are those values beyond which device damage can occur. Maximum ratings applied to the device are individual stress limit values (not normal operating conditions) and are not valid simultaneously. If these limits are exceeded, device functional operation is not implied, damage may occur and reliability may be affected.

1. Either or both input voltages should not exceed the magnitude of V_{CC} or V_{EE} .
2. Power dissipation must be considered to ensure maximum junction temperature (T_J) is not exceeded.

TCA0372, TCA0372B

DC ELECTRICAL CHARACTERISTICS ($V_{CC} = +15\text{ V}$, $V_{EE} = -15\text{ V}$, R_L connected to ground, $T_A = -40^\circ$ to $+125^\circ\text{C}$.)

Characteristics	Symbol	Min	Typ	Max	Unit
Input Offset Voltage ($V_{CM} = 0$) $T_A = +25^\circ\text{C}$ $T_A = T_{low}$ to T_{high}	V_{IO}	–	1.0	15	mV
Average Temperature Coefficient of Offset Voltage	$\Delta V_{IO}/\Delta T$	–	20	–	$\mu\text{V}/^\circ\text{C}$
Input Bias Current ($V_{CM} = 0$)	I_{IB}	–	100	500	nA
Input Offset Current ($V_{CM} = 0$)	I_{IO}	–	10	50	nA
Large Signal Voltage Gain $V_O = \pm 10\text{ V}$, $R_L = 2.0\text{ k}$	A_{VOL}	30	100	–	V/mV
Output Voltage Swing ($I_L = 100\text{ mA}$) $T_A = +25^\circ\text{C}$ $T_A = T_{low}$ to T_{high} $T_A = +25^\circ\text{C}$ $T_A = T_{low}$ to T_{high}	V_{OH} V_{OL}	14.0 13.9	14.2 –	– –	V
Output Voltage Swing ($I_L = 1.0\text{ A}$) $V_{CC} = +24\text{ V}$, $V_{EE} = 0\text{ V}$, $T_A = +25^\circ\text{C}$ $V_{CC} = +24\text{ V}$, $V_{EE} = 0\text{ V}$, $T_A = T_{low}$ to T_{high} $V_{CC} = +24\text{ V}$, $V_{EE} = 0\text{ V}$, $T_A = +25^\circ\text{C}$ $V_{CC} = +24\text{ V}$, $V_{EE} = 0\text{ V}$, $T_A = T_{low}$ to T_{high}	V_{OH} V_{OL}	22.5 22.5	22.7 –	– 1.5	V
Input Common Mode Voltage Range $T_A = +25^\circ\text{C}$ $T_A = T_{low}$ to T_{high}	V_{ICR}	V_{EE} to $(V_{CC} - 1.0)$ V_{EE} to $(V_{CC} - 1.3)$			V
Common Mode Rejection Ratio ($R_S = 10\text{ k}$)	CMRR	70	90	–	dB
Power Supply Rejection Ratio ($R_S = 100\ \Omega$)	PSRR	70	90	–	dB
Power Supply Current $T_A = +25^\circ\text{C}$ $T_A = T_{low}$ to T_{high}	I_D	–	5.0	10	mA
			8.0	10	
			–	14	
			–	14	

AC ELECTRICAL CHARACTERISTICS ($V_{CC} = +15\text{ V}$, $V_{EE} = -15\text{ V}$, R_L connected to ground, $T_A = +25^\circ\text{C}$, unless otherwise noted.)

Characteristics	Symbol	Min	Typ	Max	Unit
Slew Rate ($V_{in} = -10\text{ V}$ to $+10\text{ V}$, $R_L = 2.0\text{ k}$, $C_L = 100\text{ pF}$) $A_V = -1.0$, $T_A = T_{low}$ to T_{high}	SR	1.0	1.4	–	V/ μs
Gain Bandwidth Product ($f = 100\text{ kHz}$, $C_L = 100\text{ pF}$, $R_L = 2.0\text{ k}$) $T_A = 25^\circ\text{C}$ $T_A = T_{low}$ to T_{high}	GBW	0.9 0.7	1.4 –	– –	MHz
Phase Margin $T_J = T_{low}$ to T_{high} $R_L = 2.0\text{ k}$, $C_L = 100\text{ pF}$	ϕ_m	–	65	–	Degrees
Gain Margin $R_L = 2.0\text{ k}$, $C_L = 100\text{ pF}$	A_m	–	15	–	dB
Equivalent Input Noise Voltage $R_S = 100\ \Omega$, $f = 1.0$ to 100 kHz	e_n	–	22	–	$\text{nV}/\sqrt{\text{Hz}}$
Total Harmonic Distortion $A_V = -1.0$, $R_L = 50\ \Omega$, $V_O = 0.5\text{ VRMS}$, $f = 1.0\text{ kHz}$	THD	–	0.02	–	%

 NOTE: In case V_{EE} is disconnected before V_{CC} , a diode between V_{EE} and Ground is recommended to avoid damaging the device.

TCA0372, TCA0372B

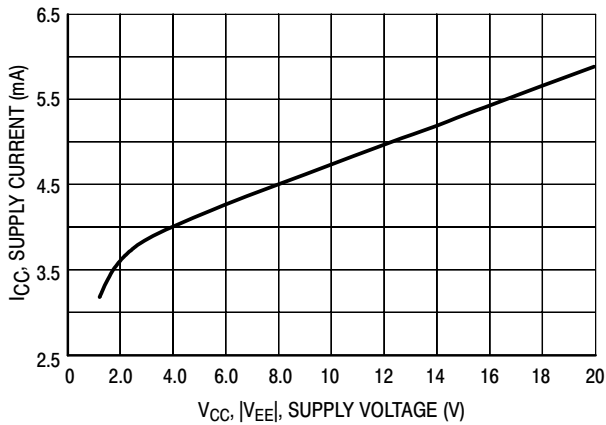

Figure 2. Supply Current versus Supply Voltage with No Load

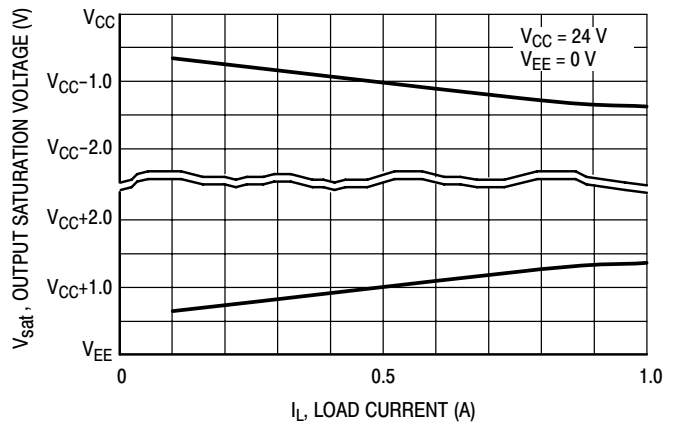

Figure 3. Output Saturation Voltage versus Load Current

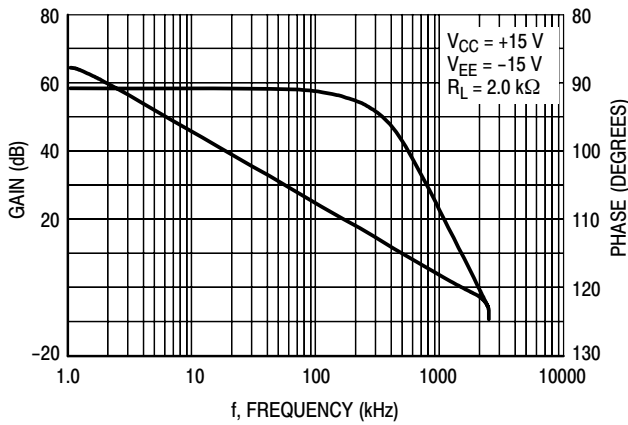

Figure 4. Voltage Gain and Phase versus Frequency

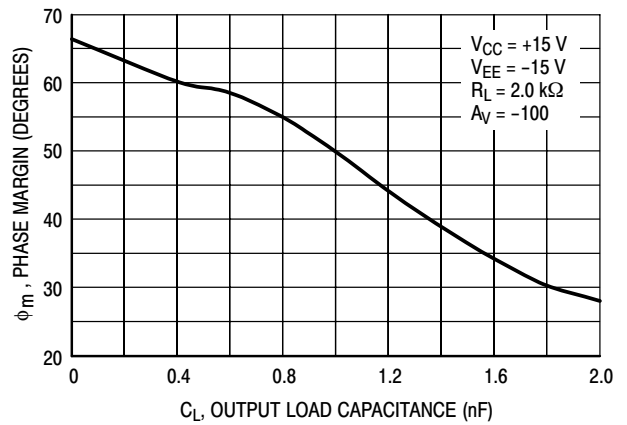

Figure 5. Phase Margin versus Output Load Capacitance

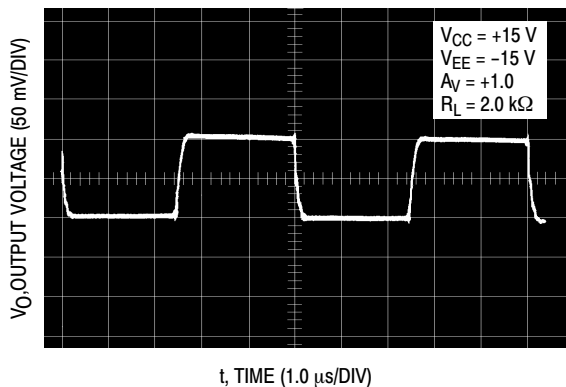

Figure 6. Small Signal Transient Response

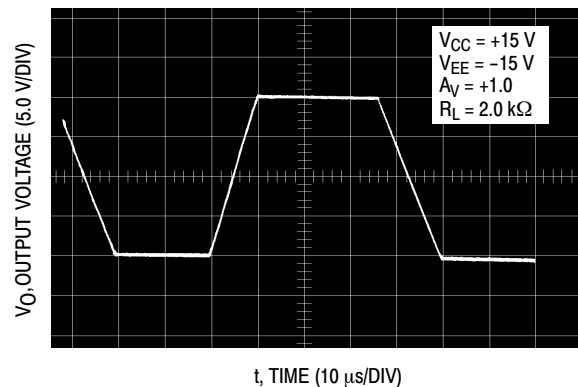

Figure 7. Large Signal Transient Response

TCA0372, TCA0372B

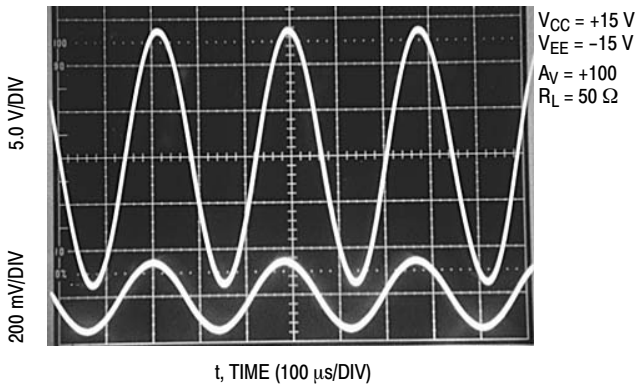

Figure 8. Sine Wave Response

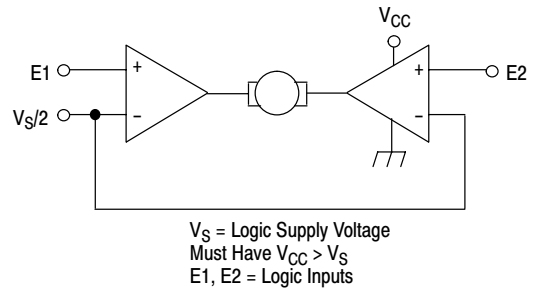
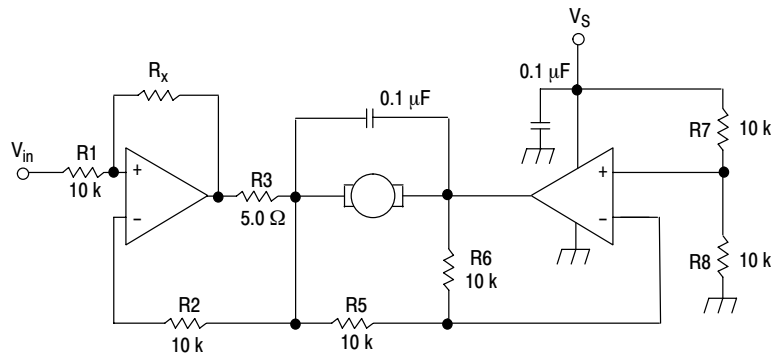

Figure 9. Bidirectional DC Motor Control with Microprocessor-Compatible Inputs



For circuit stability, ensure that $R_x > \frac{2R_3 \cdot R_1}{R_M}$ where, R_M = internal resistance of motor.

The voltage available at the terminals of the motor is: $V_M = 2 \left(V_1 - \frac{V_S}{2} \right) + |R_0| \cdot I_M$

where, $|R_0| = \frac{2R_3 \cdot R_1}{R_x}$ and I_M is the motor current.

Figure 10. Bidirectional Speed Control of DC Motors

TCA0372, TCA0372B

ORDERING INFORMATION

Device	Package	Shipping†
TCA0372DW	SOIC-16W	47 Units / Rail
TCA0372DWG	SOIC-16W (Pb-Free)	47 Units / Rail
TCA0372DWR2	SOIC-16W	1000 Tape & Reel
TCA0372DWR2G	SOIC-16W (Pb-Free)	1000 Tape & Reel
TCA0372BDWR2	SOIC-16W	1000 Tape & Reel
TCA0372BDWR2G	SOIC-16W (Pb-Free)	1000 Tape & Reel
TCA0372DP1	PDIP-8	50 Units / Rail
TCA0372DP1G	PDIP-8 (Pb-Free)	50 Units / Rail
TCA0372BDP1	PDIP-8	50 Units / Rail
TCA0372BDP1G	PDIP-8 (Pb-Free)	50 Units / Rail
TCA0372DP2	PDIP-16	25 Units / Rail
TCA0372DP2G	PDIP-16 (Pb-Free)	25 Units / Rail
TCA0372DM2EL	SOEIAJ-16	2500 Tape & Reel
TCA0372DM2ELG	SOEIAJ-16 (Pb-Free)	2500 Tape & Reel

†For information on tape and reel specifications, including part orientation and tape sizes, please refer to our Tape and Reel Packaging Specifications Brochure, BRD8011/D.

MARKING DIAGRAMS

**PDIP-8
DP1 SUFFIX
CASE 626**

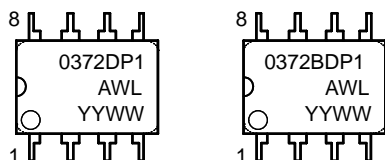

**PDIP-16
DP2 SUFFIX
CASE 648**



**SOIC-16W
DW SUFFIX
CASE 751G**

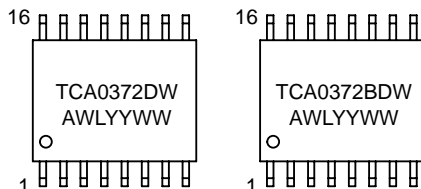

**SOEIAJ-16
DM2 SUFFIX
CASE 966**

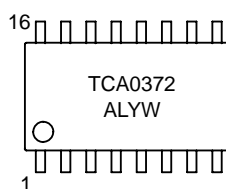

A = Assembly Location
 WL, L = Wafer Lot
 YY, Y = Year
 WW, W = Work Week

TCA0372, TCA0372B

PIN CONNECTIONS

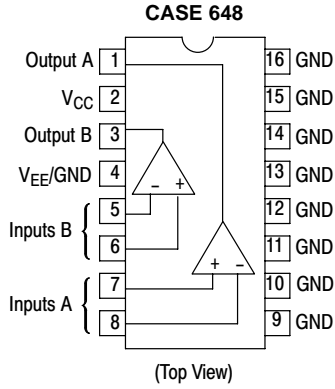

*Pins 4 and 9 to 16 are internally connected.

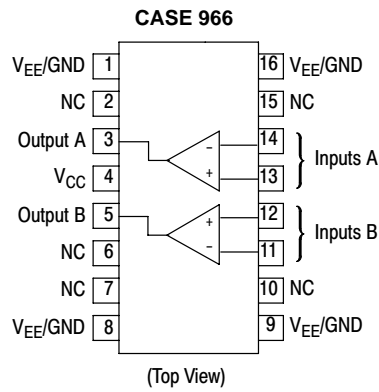
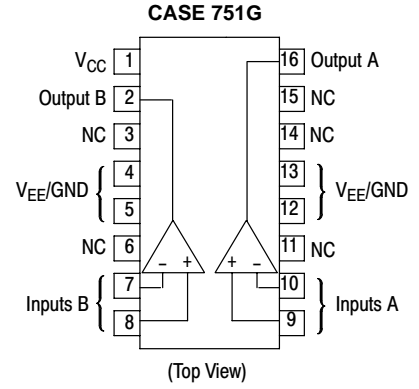
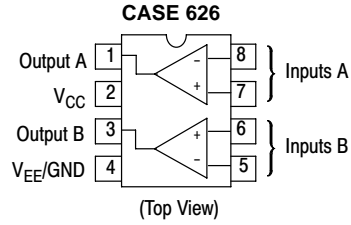

TCA0372, TCA0372B

PACKAGE DIMENSIONS

PDIP-8
DP1 SUFFIX
CASE 626-05
ISSUE L

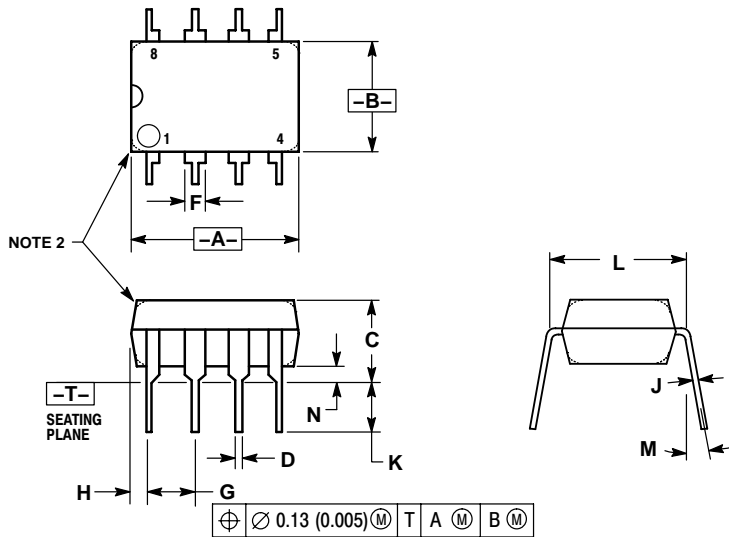

- NOTES:
1. DIMENSION L TO CENTER OF LEAD WHEN FORMED PARALLEL.
 2. PACKAGE CONTOUR OPTIONAL (ROUND OR SQUARE CORNERS).
 3. DIMENSIONING AND TOLERANCING PER ANSI Y14.5M, 1982.

DIM	MILLIMETERS		INCHES	
	MIN	MAX	MIN	MAX
A	9.40	10.16	0.370	0.400
B	6.10	6.60	0.240	0.260
C	3.94	4.45	0.155	0.175
D	0.38	0.51	0.015	0.020
F	1.02	1.78	0.040	0.070
G	2.54 BSC		0.100 BSC	
H	0.76	1.27	0.030	0.050
J	0.20	0.30	0.008	0.012
K	2.92	3.43	0.115	0.135
L	7.62 BSC		0.300 BSC	
M	---		10°	
N	0.76	1.01	0.030	0.040

PDIP-16
DP2 SUFFIX
CASE 648-08
ISSUE T

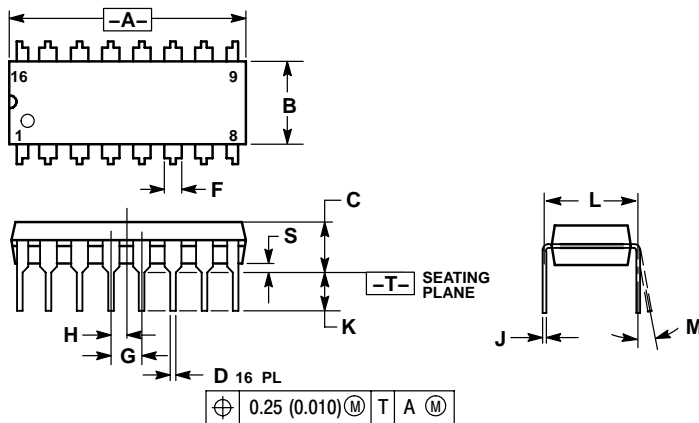

- NOTES:
1. DIMENSIONING AND TOLERANCING PER ANSI Y14.5M, 1982.
 2. CONTROLLING DIMENSION: INCH.
 3. DIMENSION L TO CENTER OF LEADS WHEN FORMED PARALLEL.
 4. DIMENSION B DOES NOT INCLUDE MOLD FLASH.
 5. ROUNDED CORNERS OPTIONAL.

DIM	INCHES		MILLIMETERS	
	MIN	MAX	MIN	MAX
A	0.740	0.770	18.80	19.55
B	0.250	0.270	6.35	6.85
C	0.145	0.175	3.69	4.44
D	0.015	0.021	0.39	0.53
F	0.040	0.70	1.02	1.77
G	0.100 BSC		2.54 BSC	
H	0.050 BSC		1.27 BSC	
J	0.008	0.015	0.21	0.38
K	0.110	0.130	2.80	3.30
L	0.295	0.305	7.50	7.74
M	0°		10°	
S	0.020	0.040	0.51	1.01

TCA0372, TCA0372B

PACKAGE DIMENSIONS

SOIC-16W
DW SUFFIX
CASE 751G-03
ISSUE B

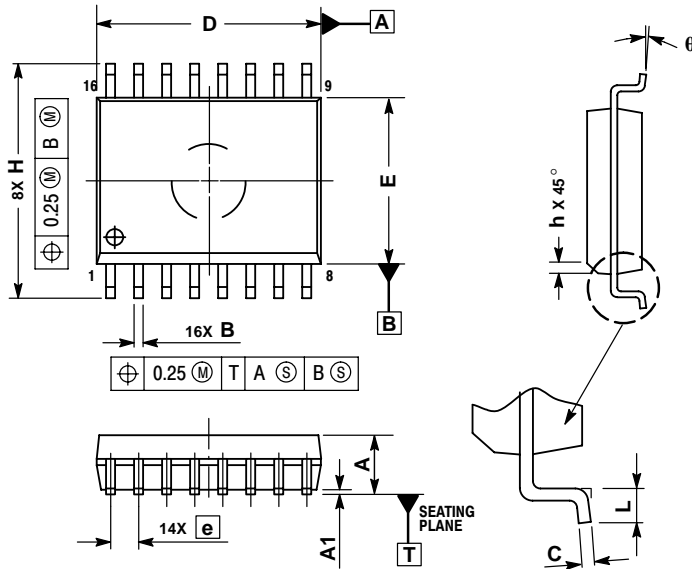

NOTES:

1. DIMENSIONS ARE IN MILLIMETERS.
2. INTERPRET DIMENSIONS AND TOLERANCES PER ASME Y14.5M, 1994.
3. DIMENSIONS D AND E DO NOT INCLUDE MOLD PROTRUSION.
4. MAXIMUM MOLD PROTRUSION 0.15 PER SIDE.
5. DIMENSION B DOES NOT INCLUDE DAMBAR PROTRUSION. ALLOWABLE DAMBAR PROTRUSION SHALL BE 0.13 TOTAL IN EXCESS OF THE B DIMENSION AT MAXIMUM MATERIAL CONDITION.

DIM	MILLIMETERS	
	MIN	MAX
A	2.35	2.65
A1	0.10	0.25
B	0.35	0.49
C	0.23	0.32
D	10.15	10.45
E	7.40	7.60
e	1.27 BSC	
H	10.05	10.55
h	0.25	0.75
L	0.50	0.90
theta	0 °	7 °

SOEIAJ-16
DM2 SUFFIX
CASE 966-01
ISSUE O

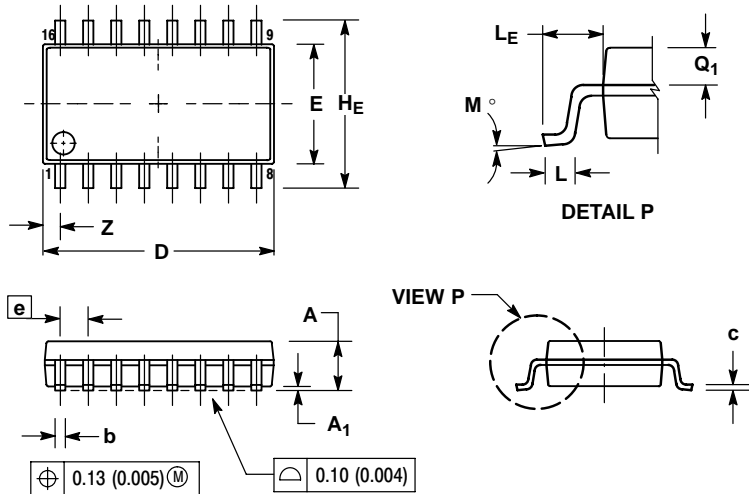

NOTES:

1. DIMENSIONING AND TOLERANCING PER ANSI Y14.5M, 1982.
2. CONTROLLING DIMENSION: MILLIMETER.
3. DIMENSIONS D AND E DO NOT INCLUDE MOLD FLASH OR PROTRUSIONS AND ARE MEASURED AT THE PARTING LINE. MOLD FLASH OR PROTRUSIONS SHALL NOT EXCEED 0.15 (0.006) PER SIDE.
4. TERMINAL NUMBERS ARE SHOWN FOR REFERENCE ONLY.
5. THE LEAD WIDTH DIMENSION (b) DOES NOT INCLUDE DAMBAR PROTRUSION. ALLOWABLE DAMBAR PROTRUSION SHALL BE 0.08 (0.003) TOTAL IN EXCESS OF THE LEAD WIDTH DIMENSION AT MAXIMUM MATERIAL CONDITION. DAMBAR CANNOT BE LOCATED ON THE LOWER RADIUS OR THE FOOT. MINIMUM SPACE BETWEEN PROTRUSIONS AND ADJACENT LEAD TO BE 0.46 (0.018).

DIM	MILLIMETERS		INCHES	
	MIN	MAX	MIN	MAX
A	---	2.05	---	0.081
A1	0.05	0.20	0.002	0.008
b	0.35	0.50	0.014	0.020
c	0.18	0.27	0.007	0.011
D	9.90	10.50	0.390	0.413
E	5.10	5.45	0.201	0.215
e	1.27 BSC		0.050 BSC	
HE	7.40	8.20	0.291	0.323
L	0.50	0.85	0.020	0.033
LE	1.10	1.50	0.043	0.059
M	0 °	10 °	0 °	10 °
Q1	0.70	0.90	0.028	0.035
Z	---	0.78	---	0.031

TCA0372, TCA0372B

ON Semiconductor and  are registered trademarks of Semiconductor Components Industries, LLC (SCILLC). SCILLC reserves the right to make changes without further notice to any products herein. SCILLC makes no warranty, representation or guarantee regarding the suitability of its products for any particular purpose, nor does SCILLC assume any liability arising out of the application or use of any product or circuit, and specifically disclaims any and all liability, including without limitation special, consequential or incidental damages. "Typical" parameters which may be provided in SCILLC data sheets and/or specifications can and do vary in different applications and actual performance may vary over time. All operating parameters, including "Typicals" must be validated for each customer application by customer's technical experts. SCILLC does not convey any license under its patent rights nor the rights of others. SCILLC products are not designed, intended, or authorized for use as components in systems intended for surgical implant into the body, or other applications intended to support or sustain life, or for any other application in which the failure of the SCILLC product could create a situation where personal injury or death may occur. Should Buyer purchase or use SCILLC products for any such unintended or unauthorized application, Buyer shall indemnify and hold SCILLC and its officers, employees, subsidiaries, affiliates, and distributors harmless against all claims, costs, damages, and expenses, and reasonable attorney fees arising out of, directly or indirectly, any claim of personal injury or death associated with such unintended or unauthorized use, even if such claim alleges that SCILLC was negligent regarding the design or manufacture of the part. SCILLC is an Equal Opportunity/Affirmative Action Employer. This literature is subject to all applicable copyright laws and is not for resale in any manner.

PUBLICATION ORDERING INFORMATION**LITERATURE FULFILLMENT:**

Literature Distribution Center for ON Semiconductor
P.O. Box 61312, Phoenix, Arizona 85082-1312 USA
Phone: 480-829-7710 or 800-344-3860 Toll Free USA/Canada
Fax: 480-829-7709 or 800-344-3867 Toll Free USA/Canada
Email: orderlit@onsemi.com

N. American Technical Support: 800-282-9855 Toll Free
USA/Canada

Japan: ON Semiconductor, Japan Customer Focus Center
2-9-1 Kamineguro, Meguro-ku, Tokyo, Japan 153-0051
Phone: 81-3-5773-3850

ON Semiconductor Website: <http://onsemi.com>

Order Literature: <http://www.onsemi.com/litorder>

For additional information, please contact your
local Sales Representative.