



Distributor of Pomona Electronics: Excellent Integrated System Limited

Datasheet of 1508/POM - HOLDER TEST LEAD WIRES .210" DIA

Contact us: sales@integrated-circuit.com Website: www.integrated-circuit.com

Excellent Integrated System Limited

Stocking Distributor

Click to view price, real time Inventory, Delivery & Lifecycle Information:

[Pomona Electronics](#)
[1508/POM](#)

For any questions, you can email us directly:

sales@integrated-circuit.com

Pomona[®]

Model 4408, 2708, 1508 Test Lead Holder

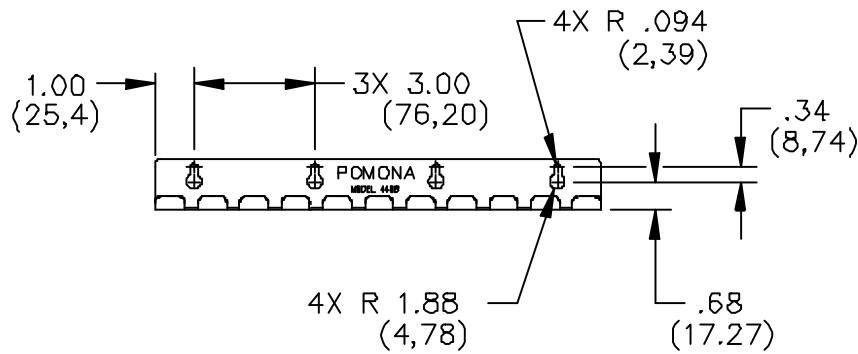
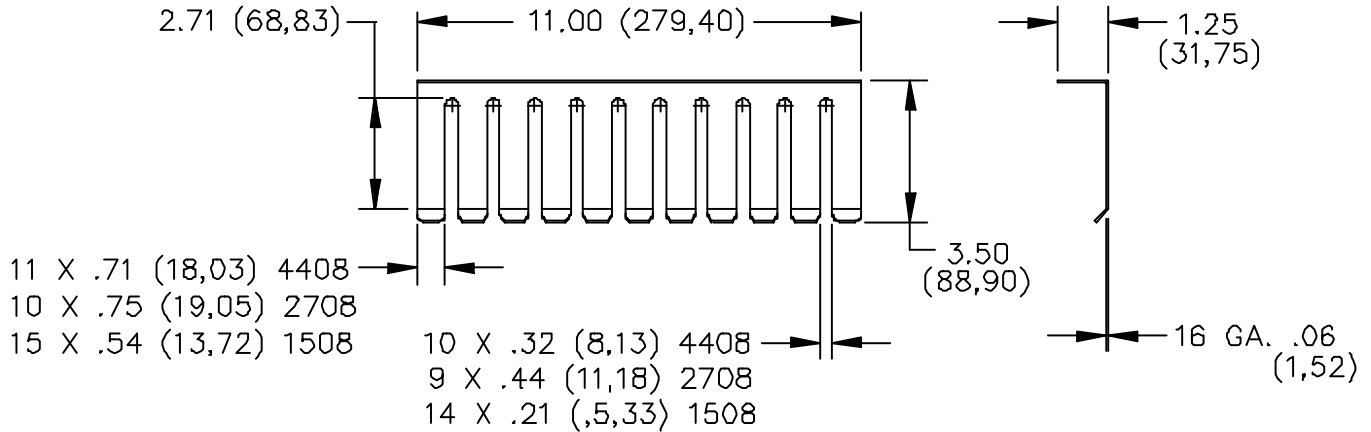

FEATURES:

- 2708 accepts cable size types RG 213 and RG 214.
- 1508 accepts cable size types RG 58 and RG 142.
- 4408 accepts cable size types RG 59 and RG 108.

MATERIALS:

Material: Cold rolled steel No.2 temper 1/2 hard.

Finish: Baked enamel.

Color: FED-STD-595A #25109, Blue (2708), #22356, Orange (1508), #27038, Black.(4408)

ORDERING INFORMATION: Model 2708, 1508, 4408

All dimensions are in inches. Tolerances (except noted): .xx = ±.02" (.51 mm), .xxx = ±.005" (.127 mm).

All specifications are to the latest revisions. Specifications are subject to change without notice.

Registered trademarks are the property of their respective companies. Made in USA