

## Excellent Integrated System Limited

Stocking Distributor

Click to view price, real time Inventory, Delivery & Lifecycle Information:

[STMicroelectronics](#)  
[BC857B](#)

For any questions, you can email us directly:

[sales@integrated-circuit.com](mailto:sales@integrated-circuit.com)



# BC857B

## SMALL SIGNAL PNP TRANSISTOR

PRELIMINARY DATA

Type	Marking
BC857B	3F

- SILICON EPITAXIAL PLANAR PNP TRANSISTOR
- MINIATURE SOT-23 PLASTIC PACKAGE FOR SURFACE MOUNTING CIRCUITS
- TAPE AND REEL PACKING
- THE NPN COMPLEMENTARY TYPE IS BC847B

### APPLICATIONS

- WELL SUITABLE FOR PORTABLE EQUIPMENT
- SMALL LOAD SWITCH TRANSISTOR WITH HIGH GAIN AND LOW SATURATION VOLTAGE

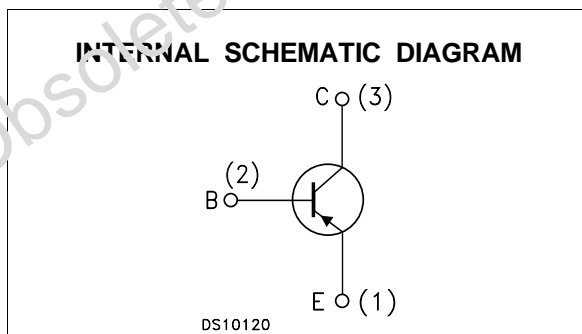

### ABSOLUTE MAXIMUM RATINGS

Symbol	Parameter	Value	Unit
$V_{CBO}$	Collector-Base Voltage ( $I_E = 0$ )	-50	V
$V_{CEO}$	Collector-Emitter Voltage ( $I_B = 0$ )	-45	V
$V_{EBO}$	Emitter-Base Voltage ( $I_C = 0$ )	-5	V
$I_C$	Collector Current	-100	mA
$I_{CM}$	Collector Peak Current	-200	mA
$P_{tot}$	Total Dissipation at $T_C = 25\text{ }^\circ\text{C}$	250	mW
$T_{stg}$	Storage Temperature	-65 to 150	$^\circ\text{C}$
$T_j$	Max. Operating Junction Temperature	150	$^\circ\text{C}$

## BC857B

### THERMAL DATA

R <sub>thj-amb</sub> •	Thermal Resistance Junction-Ambient	Max	500	°C/W
------------------------	-------------------------------------	-----	-----	------

• Device mounted on a PCB area of 1 cm<sup>2</sup>.

### ELECTRICAL CHARACTERISTICS (T<sub>case</sub> = 25 °C unless otherwise specified)

Symbol	Parameter	Test Conditions	Min.	Typ.	Max.	Unit
I <sub>CBO</sub>	Collector Cut-off Current (I <sub>E</sub> = 0)	V <sub>CB</sub> = -30 V V <sub>CB</sub> = -30 V      T <sub>C</sub> = 150 °C		-1	-15 -5	nA μA
I <sub>EBO</sub>	Emitter Cut-off Current (I <sub>C</sub> = 0)	V <sub>EB</sub> = -5 V			-100	nA
V <sub>(BR)CBO</sub>	Collector-Base Breakdown Voltage (I <sub>E</sub> = 0)	I <sub>C</sub> = -10 μA	-50			V
V <sub>(BR)CEO*</sub>	Collector-Emitter Breakdown Voltage (I <sub>B</sub> = 0)	I <sub>C</sub> = -2 mA	-45			V
V <sub>(BR)EBO</sub>	Emitter-Base Breakdown Voltage (I <sub>C</sub> = 0)	I <sub>E</sub> = -10 μA	-5			V
V <sub>CE(sat)*</sub>	Collector-Emitter Saturation Voltage	I <sub>C</sub> = -10 mA      I <sub>B</sub> = -0.5 mA I <sub>C</sub> = -100 mA      I <sub>B</sub> = -5 mA		-0.07 -0.25	-0.3 -0.65	V V
V <sub>BE(sat)*</sub>	Base-Emitter Saturation Voltage	I <sub>C</sub> = -10 mA      I <sub>B</sub> = -0.5 mA I <sub>C</sub> = -100 mA      I <sub>B</sub> = -5 mA		-0.7 -0.85		V V
V <sub>BE(on)*</sub>	Base-Emitter On Voltage	I <sub>C</sub> = -2 mA      V <sub>CE</sub> = -5 V I <sub>C</sub> = -10 mA      V <sub>CE</sub> = -5 V	-0.6	-0.65	-0.75 -0.82	V V
h <sub>FE</sub>	DC Current Gain	I <sub>C</sub> = -2 mA      V <sub>CE</sub> = -5 V	220		475	
f <sub>T</sub>	Transition Frequency	I <sub>C</sub> = -10 mA      V <sub>CE</sub> = -5 V      f = 100MHz	100			MHz
C <sub>CBO</sub>	Collector-Base Capacitance	I <sub>E</sub> = 0      V <sub>CB</sub> = -10 V      f = 1 MHz		4.5		pF
NF	Noise Figure	V <sub>CE</sub> = -5 V      I <sub>C</sub> = -0.2 mA      f = 1KHz Δf = 200 Hz      R <sub>G</sub> = 2 KΩ		2	10	dB

\* Pulsed: Pulse duration = 300 μs, duty cycle ≤ 2 %

**BC857B**

**SOT-23 MECHANICAL DATA**

DIM.	mm			mils		
	MIN.	TYP.	MAX.	MIN.	TYP.	MAX.
A	0.85		1.1	33.4		43.3
B	0.65		0.95	25.6		37.4
C	1.20		1.4	47.2		55.1
D	2.80		3	110.2		118
E	0.95		1.05	37.4		41.3
F	1.9		2.05	74.8		80.7
G	2.1		2.5	82.6		98.4
H	0.38		0.48	14.9		18.8
L	0.3		0.6	11.8		23.6
M	0		0.1	0		3.9
N	0.3		0.65	11.8		25.6
O	0.09		0.17	3.5		6.7

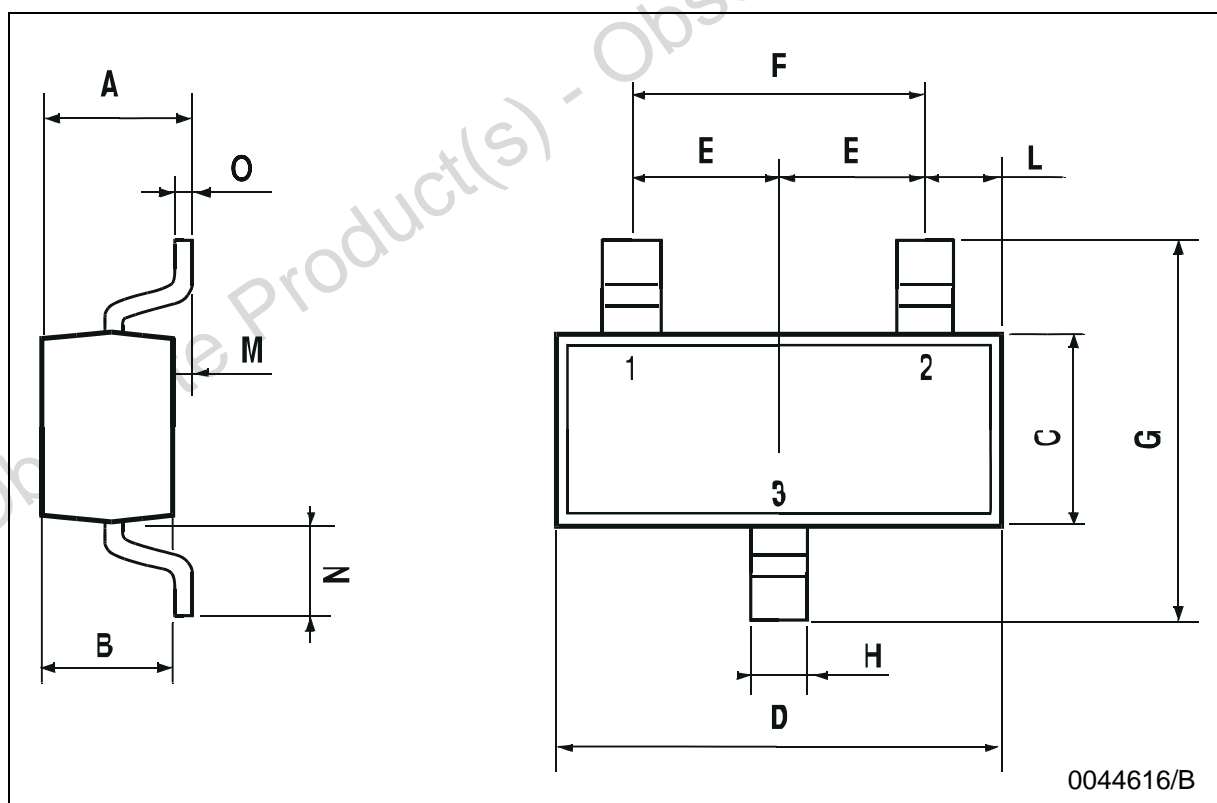

## BC857B

---

Information furnished is believed to be accurate and reliable. However, STMicroelectronics assumes no responsibility for the consequences of use of such information nor for any infringement of patents or other rights of third parties which may result from its use. No license is granted by implication or otherwise under any patent or patent rights of STMicroelectronics. Specification mentioned in this publication are subject to change without notice. This publication supersedes and replaces all information previously supplied. STMicroelectronics products are not authorized for use as critical components in life support devices or systems without express written approval of STMicroelectronics.

The ST logo is a trademark of STMicroelectronics

© 2002 STMicroelectronics – Printed in Italy – All Rights Reserved

STMicroelectronics GROUP OF COMPANIES

Australia - Brazil - Canada - China - Finland - France - Germany - Hong Kong - India - Israel - Italy - Japan - Malaysia - Malta - Morocco - Singapore - Spain - Sweden - Switzerland - United Kingdom - United States.

<http://www.st.com>