

Excellent Integrated System Limited

Stocking Distributor

Click to view price, real time Inventory, Delivery & Lifecycle Information:

[Pomona Electronics](#)
[4243-0](#)

For any questions, you can email us directly:

sales@integrated-circuit.com

Pomona®

Model 4243
Double Binding Post Assembly

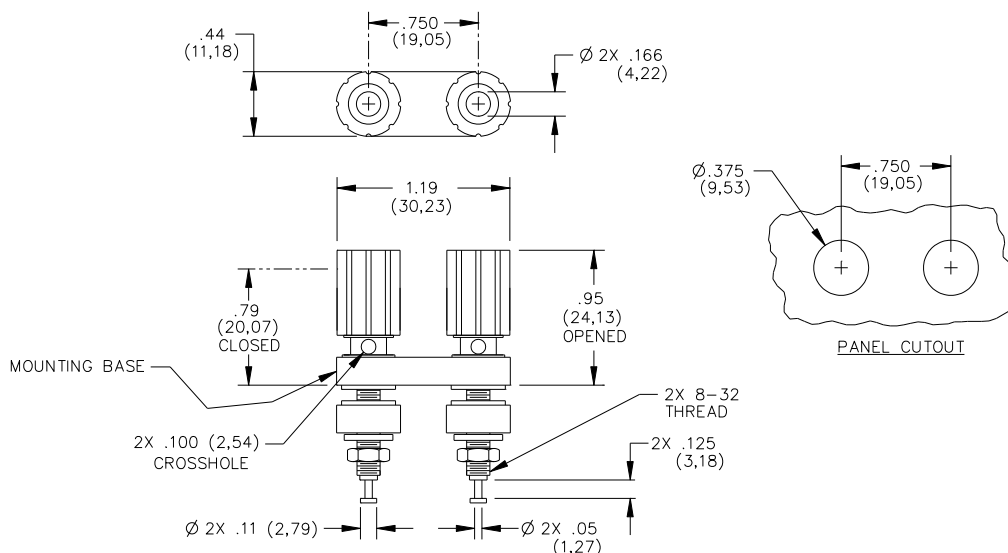

FEATURES:

- Accepts standard banana plugs
- Mounts in panels from 1.57 (.062) to 6.35 (.250) thick.

MATERIALS:

Insulated Captive Thumb Nut: Brass
 Finish: Tin plated brass
 Insulation: Polycarbonate
 Mounting Base: Polycarbonate
 Insulator: Polycarbonate
 Lockwasher: Steel
 Hex Nut: Brass
 Binding Post: Bright Tin plated brass

RATINGS:

Voltage: Hand-held testing: 30VAC/60VDC Max.
 Hands free testing in controlled voltage environments: 2500 WVDC Max.
 Operating Temperature: +115°C (+239°F) Max.
 Current: 15 Amperes

ORDERING INFORMATION: Model 4243-*

*=Mounting Base Color, -0 Black, -2 Red

Ordering Example: 4243-2 Color is Red

All dimensions are in inches. Tolerances (except noted): .xx = ±.02" (.51 mm), .xxx = ±.005" (.127 mm).
 All specifications are to the latest revisions. Specifications are subject to change without notice.
 Registered trademarks are the property of their respective companies. Made in USA