

Excellent Integrated System Limited

Stocking Distributor

Click to view price, real time Inventory, Delivery & Lifecycle Information:

[TDK Corporation](#)
[CXA-P1212A-WJL](#)

For any questions, you can email us directly:

sales@integrated-circuit.com

Power Supplies

CXA Series CXA-P1212A-WJL

DC to AC Inverters

Connector type, Dimming, 8W, For 2 Bulbs

FEATURES

- Optimum one-connector, two-output design for thin liquid crystal panel displays.
- This inverter carries a PWM(pulse modulation width) circuit, TDK's unique circuit design. This allows dimming of lighting over a much wider range than is possible using conventional types of dimmer circuits. The type of dimmer control can be selected as desired, either voltage control(Vbr:0 to 1.6V) or resistance control(VR:0 to 10kΩ).
- Built-in overcurrent protection circuit increases safety.
- Monitor brightness is always kept stable since the built-in current feedback illumination stabilization circuit compensates for inverter input voltage variation(±10%).
- The board backside is free of wiring pattern. Cost reduction and simplified mounting are made possible by a design that only uses one side of the board.
- Operational safety is increased by the use of two types of insulation for high voltage components.

APPLICATIONS

Various types of color liquid crystal displays, computer touch panels, controllers, medical devices, ATMs, POS terminals, telecommunication terminals, microscope monitors, fishdetectors, ticket sales machines, amusement arcade machines.

TEMPERATURE AND HUMIDITY RANGES

Temperature range (°C)	Operating	-10 to +70
	Storage	-30 to +85
Humidity range(%)RH		95max.
		[Maximum wet-bulb temperature 38°C]

SHAPES AND DIMENSIONS

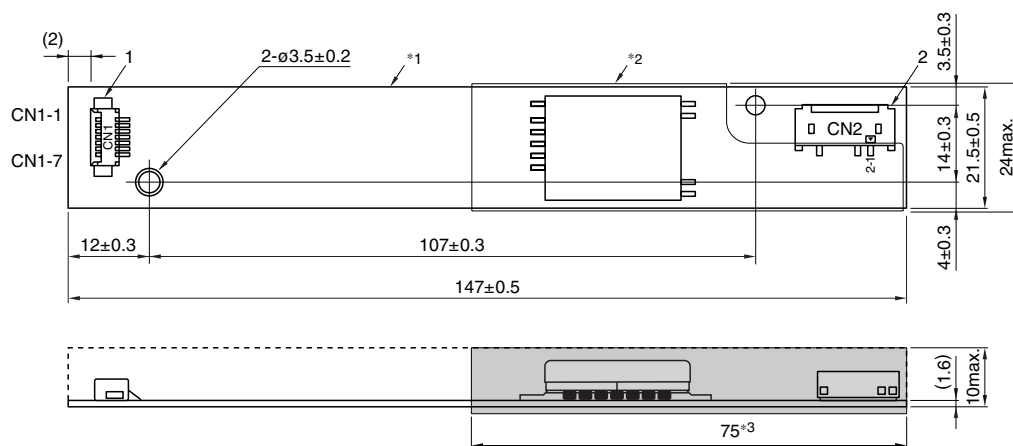

*1 Substrate(PWB: Printed wiring board): Flame retardant material UL 94V-0(FR-4 or CEM-3)

Weight: 24.5g typ.

*2 Voltage protection insulating cover t=0.38mm

Dimensions in mm

*3 : High-voltage generator (The entire surface within a range of 75mm away from the end of the base in the output)

	Connector manufacturer's company and type	Symbol
1 Input connector	Morex Japan Co., Ltd. 53261-0790	CN1
2 Output connector	Japan Solderless Terminal Co., Ltd. SM03(7-D1)B-BHS-1	CN2

TERMINAL NUMBERS AND FUNCTIONS

CN1

Terminal No.	Functions	Symbol
CN1-1,-2	Input voltage Edc: 10.8 to 13.2V 12V[nom.]	Vin
CN1-3,-4	0V	GND
CN1-5	Remote voltage Edc 0V: off/5 to 13.2V:on	Vrmt
CN1-6	Brightness dimmer terminal: GND/0 to 10kΩ*	Vbr1/VR1
CN1-7	Brightness dimmer terminal: 0 to 0.6V/0 to 10kΩ* Vbr2/VR2	

CN2

Terminal No.	Functions	Symbol
CN2-1	Output 1[High voltage] Irms 2 to 6mA	VHIGH1
CN2-2	Output 2[High voltage] Irms 2 to 6mA	VHIGH2
CN2-3	—	N.C.
CN2-4	Output[Low voltage] (2V)	VLOW

* According to a connection method, either a voltage control brightness adjustment or a resistance control brightness adjustment can be selected as follows:

Voltage control brightness adjustment: 0V → Maximum brightness adjustment (Maximum light volume), 0.6V → Minimum brightness adjustment (Minimum light volume)

Resistance control brightness adjustment: 0Ω → Maximum brightness adjustment (Maximum light volume), 10kΩ → Minimum brightness adjustment (Minimum light volume)

Power Supplies

CXA Series CXA-P1212A-WJL

DC to AC Inverters

Connector type, Dimming, 8W, For 2 Bulbs

ELECTRICAL CHARACTERISTICS

Items	Unit	Symbol	Specifications			Conditions						
			min.	typ.	max.	Vin(V)	Vrmt(V)	Vbr(V)*1	VR(kΩ)*2	Ta(°C)	RL1/RL2	Brightness
Output current I _{rms}	mA	lout1/lout2	5.3	6	6.7	12±1.2	5±0.25	0	0	-10 to +70	95 to 116	Maximum
		lout1/lout2	5.5	6	6.5	12±0.6	5±0.25	0	0	23±5	106	Maximum
		lout1/lout2	1.1	2	2.9	12±1.2	5±0.25	0.6	10	-10 to +70	95 to 116	Minimum
		lout1/lout2	1.2	2	2.8	12±0.6	5±0.25	0.6	10	23±5	106±0.5	Minimum
Input current I _{dc}	A	lin1	—	0.8	1	12±0.6	5±0.25	0	0	23±5	106	
	mA	lin2	—	—	1	12±0.6	0 to 0.4	0	0	23±5	95 to 116	
	mA	lin3*3	—	—	1	12±1.2	5±0.25	0 to 0.6	0 to 10	-10 to +70	∞	3sec typ.
Oscillation frequency	kHz	FL	35	40	45	12±0.6	5±0.25	0	0	-10 to +70	95 to 116	
Open circuit output voltage Erms	V	Vopen	1500	1700	—	10.8	5±0.25	0	0	-10 to +70	∞	

• This product permits a selection between the voltage control brightness adjustment and the resistance control brightness adjustment according to a connection method.

*1 When voltage control brightness adjustment is selected.

*2 When resistance control brightness adjustment is selected.

*3 This inverter has a built-in feature which stops an operation in approx. 3 sec when the RL1 and the RL2 are open at the start-up of the inverter or when they are opened during the inverter operation.

TYPICAL CONNECTION

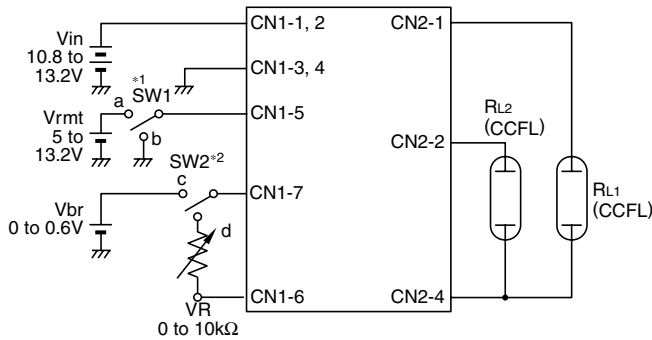

*1 SW1 Remote function a: on, b: off

*2 SW2 Dimmer control method c: voltage dimmer control, d: resistance dimmer control

Vbr vs. I_{out} CHARACTERISTICS VR vs. I_{out} CHARACTERISTICS

