

## Excellent Integrated System Limited

Stocking Distributor

Click to view price, real time Inventory, Delivery & Lifecycle Information:

[STMicroelectronics](#)

[DB3TG](#)

For any questions, you can email us directly:

[sales@integrated-circuit.com](mailto:sales@integrated-circuit.com)



# DB3TG

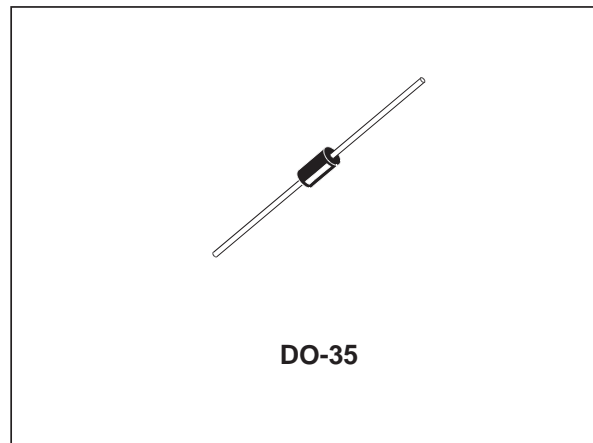
## DIAC

### FEATURES

- $V_{BO}$  : 32V
- Low breakover current: 15 $\mu$ A max
- Breakover voltage range: 30 to 34V

### DESCRIPTION

Functioning as a trigger diode with a fixed voltage reference, the DB3TG can be used in conjunction with triacs for simplified gate control circuits or as a starting element in fluorescent lamp ballasts.



### ABSOLUTE MAXIMUM RATINGS (limiting values)

Symbol	Parameter	Value	Unit
$I_{TRM}$	Repetitive peak on-state current $t_p = 20 \mu s$ $F = 120 \text{ Hz}$	2	A
$T_{stg}$ $T_j$	Storage temperature range Operating junction temperature range	- 40 to + 125	$^{\circ}C$

## DB3TG

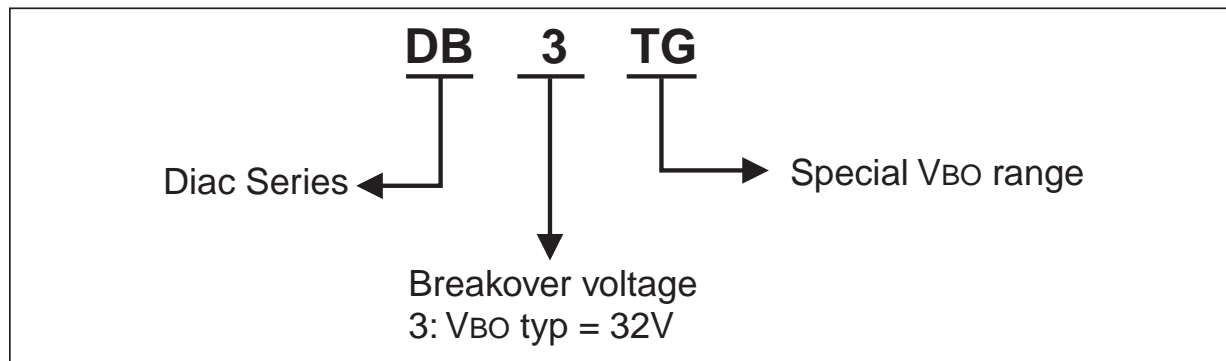
### ELECTRICAL CHARACTERISTICS (Tj = 25°C unless otherwise specified)

Symbol	Parameter	Test Conditions	Value	Unit	
V <sub>BO</sub>	Breakover voltage *	C = 22nF **	MIN.	30	V
			TYP.	32	
			MAX.	34	
V <sub>BO1</sub> - V <sub>BO2</sub>	Breakover voltage symmetry	C = 22nF **	MAX.	± 2	V
ΔV	Dynamic breakover voltage *	V <sub>BO</sub> and V <sub>F</sub> at 10mA	MIN.	9	V
V <sub>O</sub>	Output voltage *	see diagram 2 (R=20Ω)	MIN.	5	V
I <sub>BO</sub>	Breakover current *	C = 22nF **	MAX.	15	μA
tr	Rise time *	see diagram 3	MAX.	2	μs
I <sub>R</sub>	Leakage current *	V <sub>R</sub> = 0.5 V <sub>BO</sub> max	MAX.	10	μA

\* Applicable to both forward and reverse directions.

\*\* Connected in parallel to the device.

### ORDERING INFORMATION

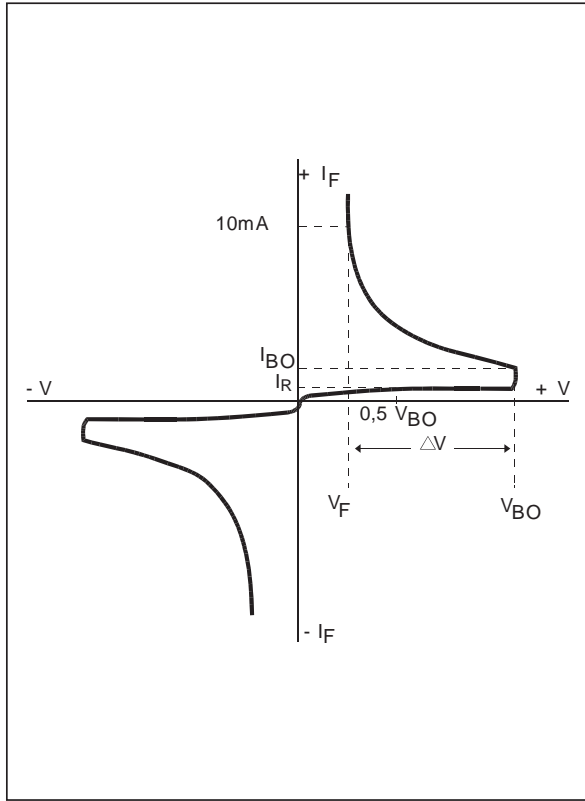


### OTHER INFORMATION

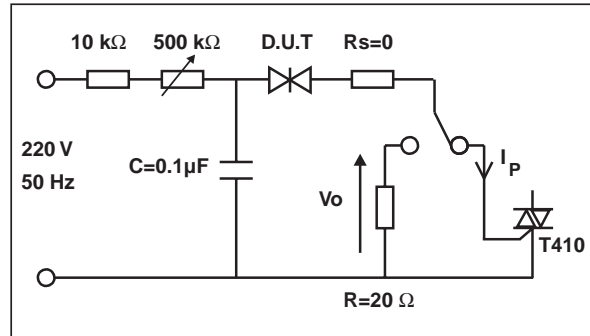
Part Number	Marking	Weight	Base Quantity	Packing Mode
DB3TG	DB3TG (Blue Body Coat)	0.15 g	5000	Tape & Reel

**DB3TG**

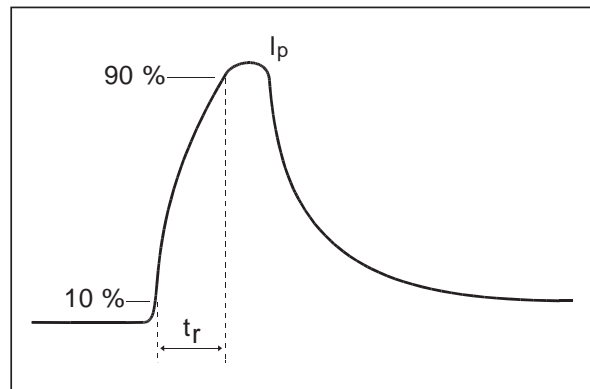
**Diagram 1:** Voltage - current characteristic curve.



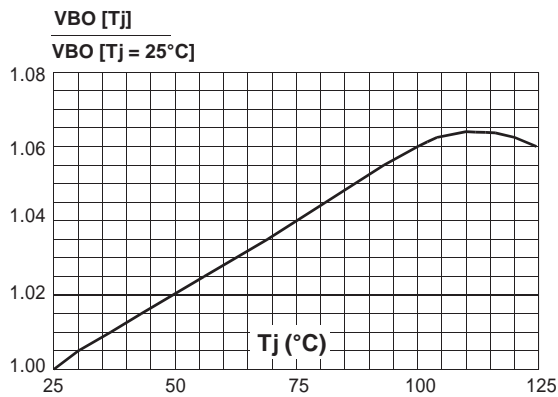
**Diagram 2:** Test circuit.



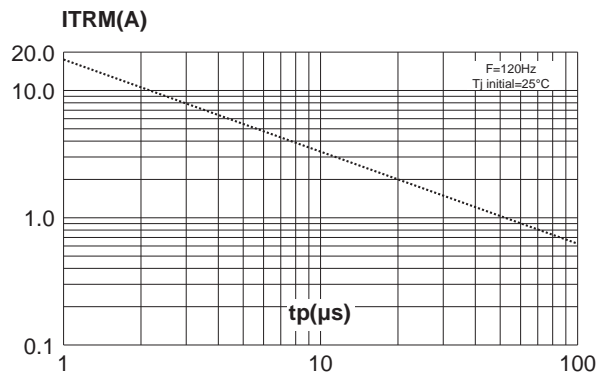
**Diagram 3:** Rise time measurement.



**Fig. 1:** Relative variation of VBO versus junction temperature (typical values)

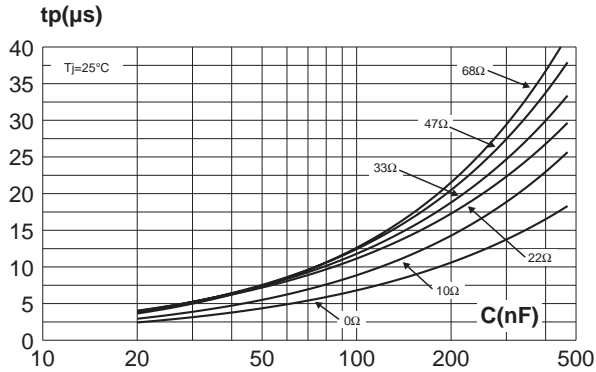


**Fig. 2:** Repetitive peak pulse current versus pulse duration (maximum values).

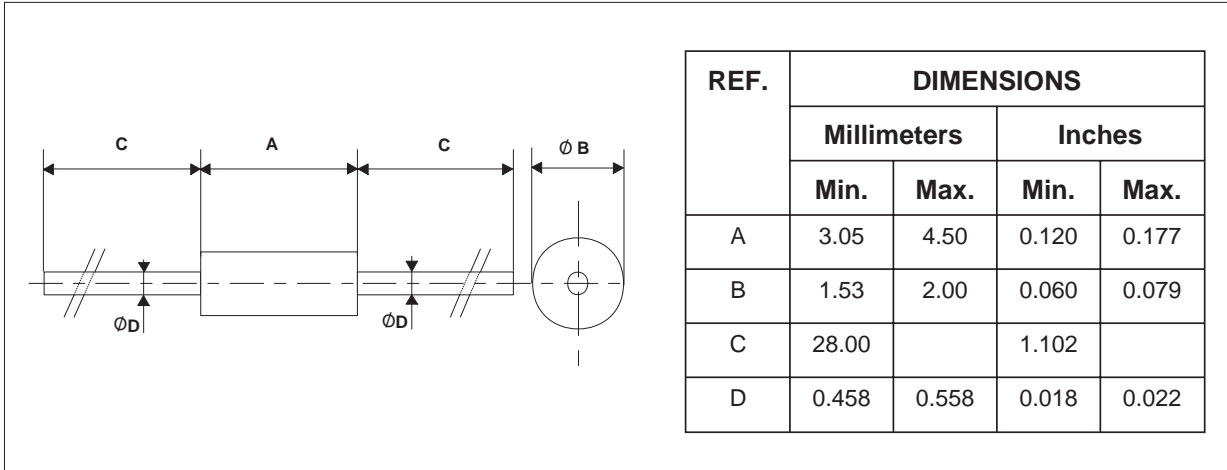


**DB3TG**

**Fig. 3:** Time duration while current pulse is higher 50mA versus C and Rs (typical values).



**PACKAGE MECHANICAL DATA (in millimeters)**  
DO-35



Information furnished is believed to be accurate and reliable. However, STMicroelectronics assumes no responsibility for the consequences of use of such information nor for any infringement of patents or other rights of third parties which may result from its use. No license is granted by implication or otherwise under any patent or patent rights of STMicroelectronics. Specifications mentioned in this publication are subject to change without notice. This publication supersedes and replaces all information previously supplied. STMicroelectronics products are not authorized for use as critical components in life support devices or systems without express written approval of STMicroelectronics.

The ST logo is a registered trademark of STMicroelectronics  
© 2001 STMicroelectronics - Printed in Italy - All rights reserved.

STMicroelectronics GROUP OF COMPANIES  
Australia - Brazil - China - Finland - France - Germany - Hong Kong - India - Italy - Japan - Malaysia  
Malta - Morocco - Singapore - Spain - Sweden - Switzerland - United Kingdom - U.S.A.

<http://www.st.com>