

Excellent Integrated System Limited

Stocking Distributor

Click to view price, real time Inventory, Delivery & Lifecycle Information:

[STMicroelectronics](#)

[STS5PF30L](#)

For any questions, you can email us directly:

sales@integrated-circuit.com



STS5PF30L

P-channel 30V - 0.045Ω - 5A SO-8
 STripFET™ Power MOSFET

General features

Type	V _{DSS}	R _{DS(on)}	I _D
STS5PF30L	30V	<0.055Ω	5A

- Conduction losses reduced
- Switching losses reduced
- Low threshold drive
- Standard outline for easy automated surface mount assembly

Description

This Power MOSFET is the latest development of STMicroelectronics unique “single feature size™” strip-based process. The resulting transistor shows extremely high packing density for low on-resistance, rugged avalanche characteristics and less critical alignment steps therefore a remarkable manufacturing reproducibility.

Applications

- Switching application

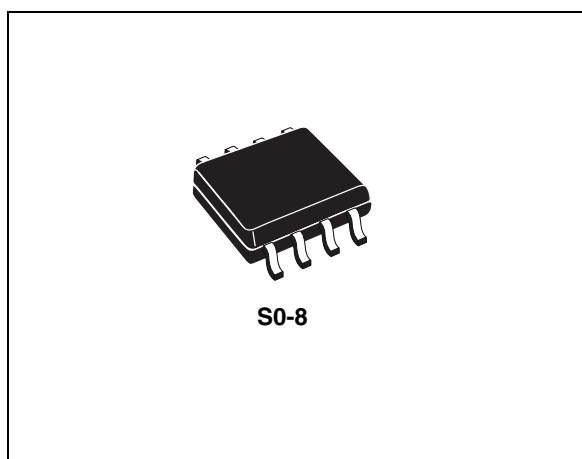

Internal schematic diagram

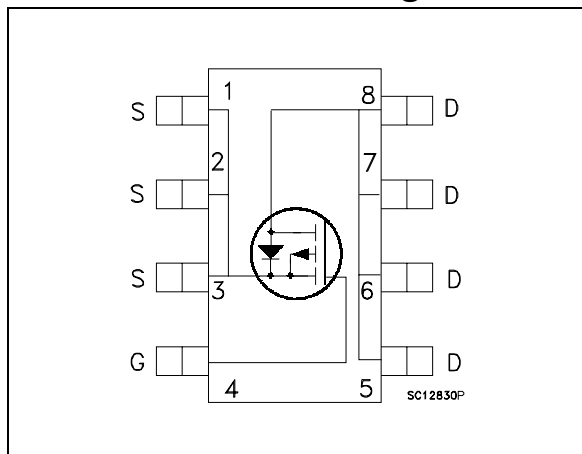

Order code

Part number	Marking	Package	Packaging
STS5PF30L	S5PF30L	SO-8	Tape & reel

Contents

1	Electrical ratings	3
2	Electrical characteristics	4
2.1	Electrical characteristics (curves)	6
3	Test circuit	8
4	Package mechanical data	9
5	Revision history	11

1 Electrical ratings

Table 1. Absolute maximum ratings

Symbol	Parameter	Value	Unit
V_{DS}	Drain-source voltage ($v_{gs} = 0$)	30	V
V_{GS}	Gate- source voltage	± 16	V
I_D	Drain current (continuous) at $T_C = 25^\circ\text{C}$	5	A
I_D	Drain current (continuous) at $T_C = 100^\circ\text{C}$	4	A
$I_{DM}^{(1)}$	Drain current (pulsed)	20	A
P_{TOT}	Total dissipation at $T_C = 25^\circ\text{C}$ dual operating	2.5	W
T_J	Junction temperature	-55 to 150	$^\circ\text{C}$
T_{stg}	Storage temperature range	150	$^\circ\text{C}$

1. Pulse width limited by safe operating area

Note: For the p-channel Power MOSFET actual polarity of voltages and current has to be reversed

Table 2. Thermal data

R_{thj-a}	⁽¹⁾ Thermal resistance junction-ambient Max	50	$^\circ\text{C/W}$
T_L	Maximum lead temperature for soldering purpose	300	$^\circ\text{C}$

1. Mounted on FR-4 board ($t \leq 10\text{sec}$)

2 Electrical characteristics

(T_{CASE}=25°C unless otherwise specified)

Table 3. On/off states

Symbol	Parameter	Test conditions	Min.	Typ.	Max.	Unit
V _{(BR)DSS}	Drain-source breakdown voltage	I _D = 250 μA, V _{GS} = 0	30			V
I _{DSS}	Zero gate voltage Drain current (V _{GS} = 0)	V _{DS} = Max rating V _{DS} =Max rating, T _C =125°C			1 10	μA μA
I _{GSS}	Gate-body leakage current (V _{DS} = 0)	V _{GS} = ± 16V			±100	nA
V _{GS(th)}	Gate threshold voltage	V _{DS} = V _{GS} , I _D = 250μA	1	1.6	2.5	V
R _{DS(on)}	Static drain-source on resistance	V _{GS} = 10V, I _D = 2.5A V _{GS} = 4.5V, I _D = 2.5A		0.045 0.065	0.055 0.075	Ω Ω

Table 4. Dynamic

Symbol	Parameter	Test conditions	Min.	Typ.	Max.	Unit
g _{fs} ⁽¹⁾	Forward transconductance	V _{DS} = 15V, I _D =2.5A		10		S
C _{iss}	Input capacitance	V _{DS} = 25V, f = 1 MHz, V _{GS} = 0		1350		pF
C _{oss}	Output capacitance			490		pF
C _{rss}	Reverse transfer capacitance			130		pF
Q _g	Total gate charge	V _{DD} = 24V, I _D = 5A, V _{GS} = 5V <i>(see Figure 14)</i>		12.5	16	nC
Q _{gs}	Gate-source charge			5		nC
Q _{gd}	Gate-drain charge			3		nC

1. Pulsed: Pulse duration = 300 μs, duty cycle 1.5.

STS5PF30L
Electrical characteristics
Table 5. Switching times

Symbol	Parameter	Test conditions	Min.	Typ.	Max.	Unit
$t_{d(on)}$ t_r	Turn-on delay time Rise time	$V_{DD}=15\text{ V}$, $I_D=2.5\text{ A}$, $R_G=4.7\Omega$, $V_{GS}=4.5\text{ V}$ (see Figure 13)		25 35		ns ns
$t_{d(off)}$ t_f	Turn-off Delay Time Fall Time	$V_{DD}=15\text{ V}$, $I_D=2.5\text{ A}$, $R_G=4.7\Omega$, $V_{GS}=4.5\text{ V}$ (see Figure 13)		125 35		ns ns

Table 6. Source drain diode

Symbol	Parameter	Test conditions	Min	Typ.	Max	Unit
I_{SD}	Source-drain current				5	A
$I_{SDM}^{(1)}$	Source-drain current (pulsed)				20	A
$V_{SD}^{(2)}$	Forward on voltage	$I_{SD} = 5\text{ A}$, $V_{GS} = 0$			1.2	V
t_{rr} Q_{rr} I_{RRM}	Reverse recovery time Reverse recovery charge Reverse recovery current	$I_{SD} = 5\text{ A}$, $V_{DD} = 15\text{ V}$ $di/dt = 100\text{ A}/\mu\text{s}$, $T_j = 150^\circ\text{C}$ (see Figure 15)		45 36 1.6		ns nC A

1. Pulse width limited by safe operating area.
2. Pulsed: Pulse duration = 300 μs , duty cycle 1.5%

Electrical characteristics

STS5PF30L

2.1 Electrical characteristics (curves)

Figure 1. Safe operating area

Figure 2. Thermal impedance

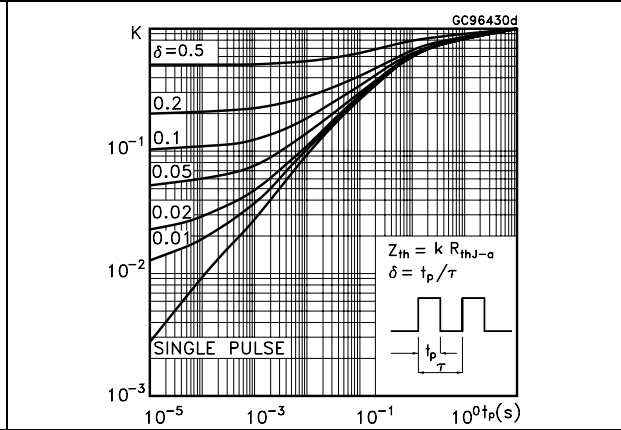
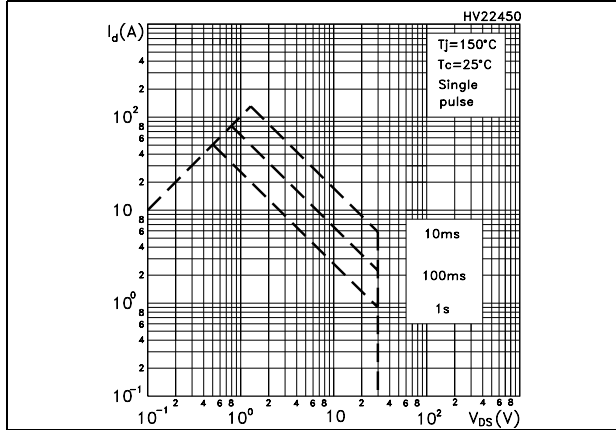

Figure 3. Output characteristics

Figure 4. Transfer characteristics

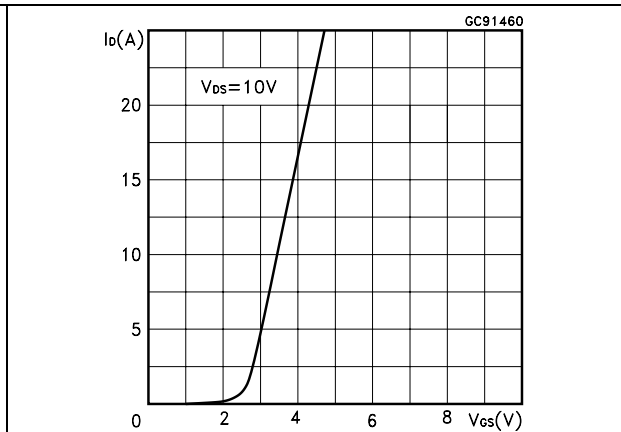
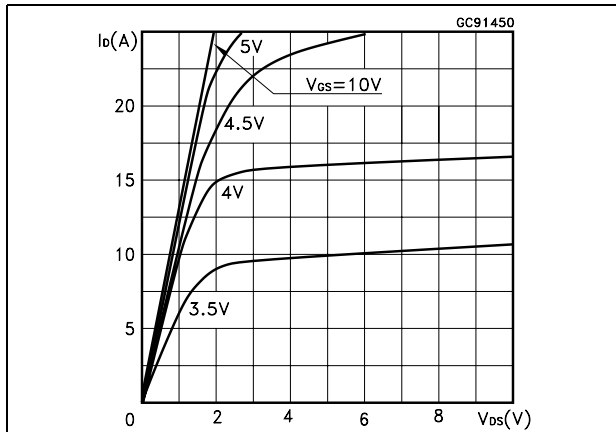
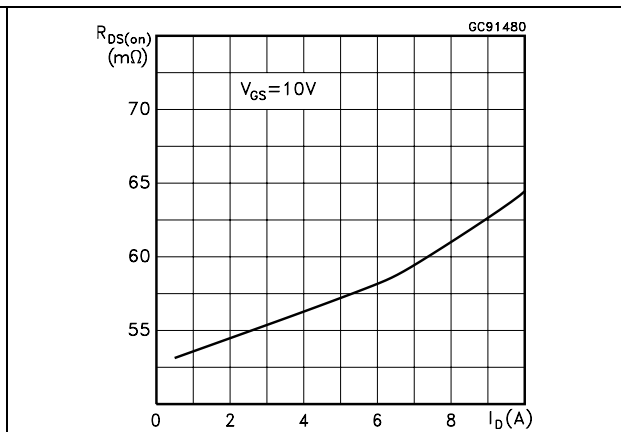
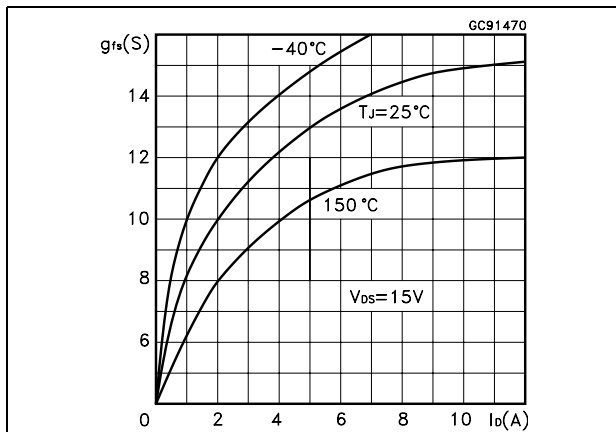

Figure 5. Transconductance

Figure 6. Static drain-source on resistance



STS5PF30L

Electrical characteristics

Figure 7. Gate charge vs gate-source voltage **Figure 8. Capacitance variations**

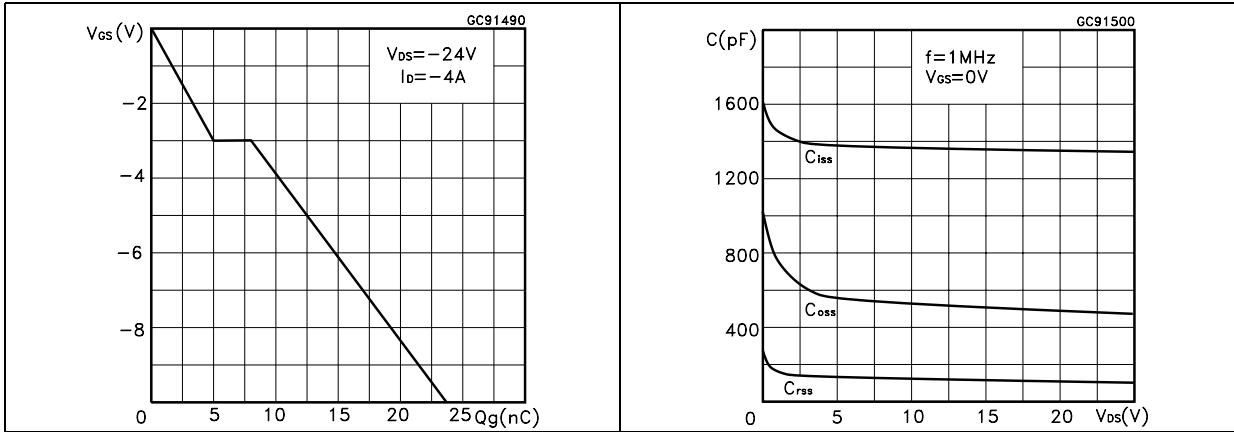

Figure 9. Normalized gate threshold voltage vs temperature **Figure 10. Normalized on resistance vs temperature**

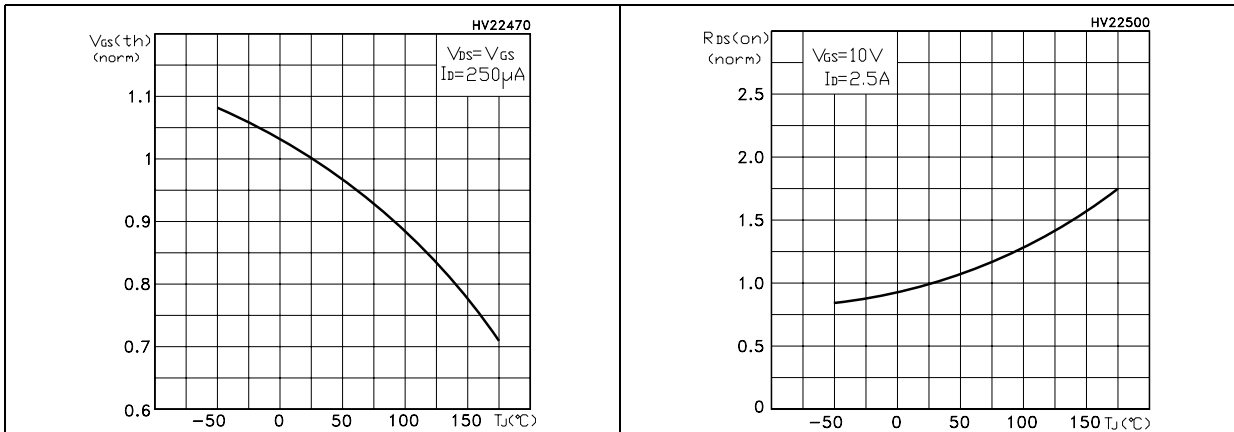
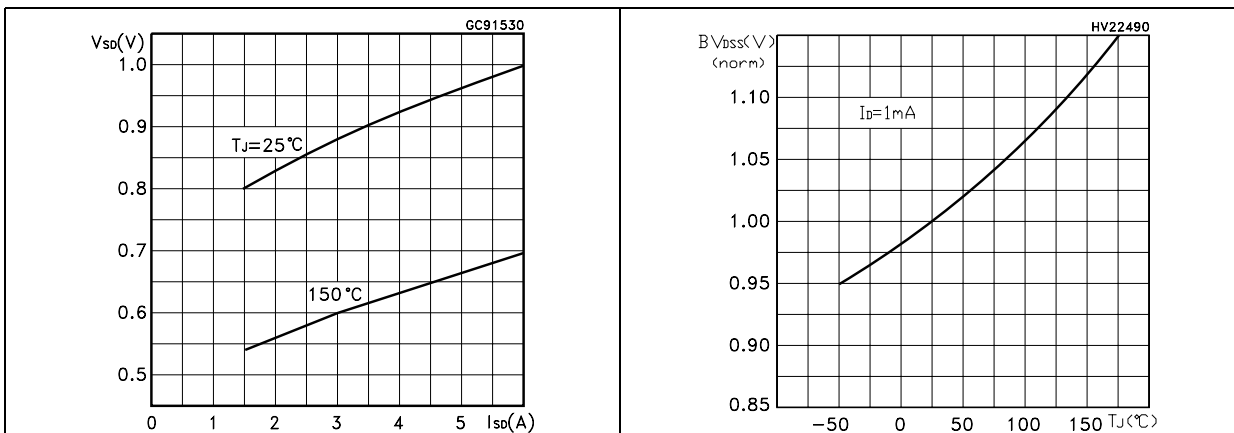

Figure 11. Source-drain diode forward characteristics **Figure 12. Normalized BV_{DSS} vs temperature**



3 Test circuit

Figure 13. Switching times test circuit for resistive load

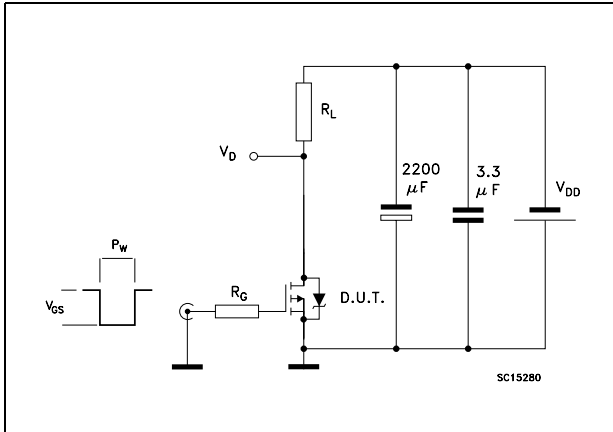

Figure 14. Gate charge test circuit

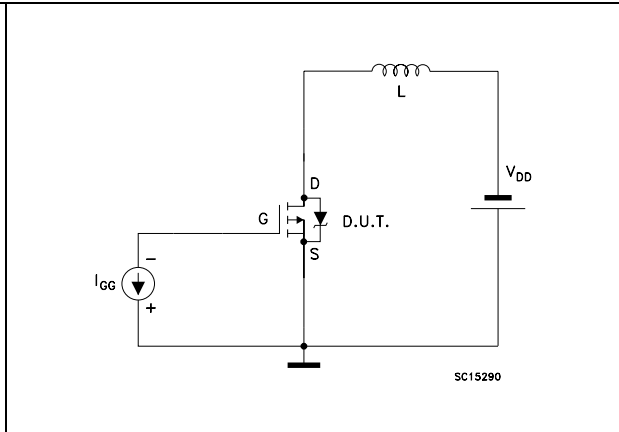
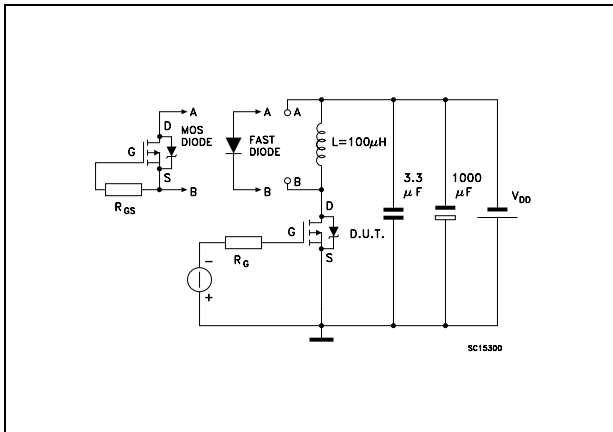

Figure 15. Test circuit for diode recovery behavior



4 Package mechanical data

In order to meet environmental requirements, ST offers these devices in ECOPACK® packages. These packages have a Lead-free second level interconnect. The category of second level interconnect is marked on the package and on the inner box label, in compliance with JEDEC Standard JESD97. The maximum ratings related to soldering conditions are also marked on the inner box label. ECOPACK is an ST trademark. ECOPACK specifications are available at: www.st.com

Package mechanical data

STS5PF30L

SO-8 MECHANICAL DATA						
DIM.	mm.			inch		
	MIN.	TYP.	MAX.	MIN.	TYP.	MAX.
A			1.75			0.068
a1	0.1		0.25	0.003		0.009
a2			1.65			0.064
a3	0.65		0.85	0.025		0.033
b	0.35		0.48	0.013		0.018
b1	0.19		0.25	0.007		0.010
C	0.25		0.5	0.010		0.019
c1	45 (typ.)					
D	4.8		5.0	0.188		0.196
E	5.8		6.2	0.228		0.244
e		1.27			0.050	
e3		3.81			0.150	
F	3.8		4.0	0.14		0.157
L	0.4		1.27	0.015		0.050
M			0.6			0.023
S	8 (max.)					

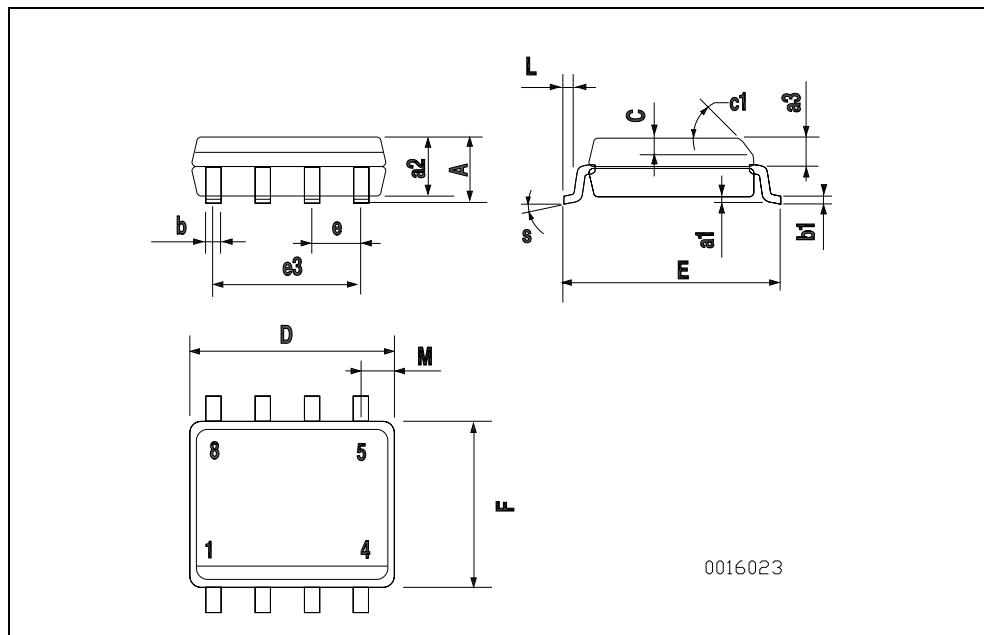

5 Revision history

Table 7. Revision history

Date	Revision	Changes
06-Feb-2007	4	The document has been reformatted

Please Read Carefully:

Information in this document is provided solely in connection with ST products. STMicroelectronics NV and its subsidiaries ("ST") reserve the right to make changes, corrections, modifications or improvements, to this document, and the products and services described herein at any time, without notice.

All ST products are sold pursuant to ST's terms and conditions of sale.

Purchasers are solely responsible for the choice, selection and use of the ST products and services described herein, and ST assumes no liability whatsoever relating to the choice, selection or use of the ST products and services described herein.

No license, express or implied, by estoppel or otherwise, to any intellectual property rights is granted under this document. If any part of this document refers to any third party products or services it shall not be deemed a license grant by ST for the use of such third party products or services, or any intellectual property contained therein or considered as a warranty covering the use in any manner whatsoever of such third party products or services or any intellectual property contained therein.

UNLESS OTHERWISE SET FORTH IN ST'S TERMS AND CONDITIONS OF SALE ST DISCLAIMS ANY EXPRESS OR IMPLIED WARRANTY WITH RESPECT TO THE USE AND/OR SALE OF ST PRODUCTS INCLUDING WITHOUT LIMITATION IMPLIED WARRANTIES OF MERCHANTABILITY, FITNESS FOR A PARTICULAR PURPOSE (AND THEIR EQUIVALENTS UNDER THE LAWS OF ANY JURISDICTION), OR INFRINGEMENT OF ANY PATENT, COPYRIGHT OR OTHER INTELLECTUAL PROPERTY RIGHT.

UNLESS EXPRESSLY APPROVED IN WRITING BY AN AUTHORIZED ST REPRESENTATIVE, ST PRODUCTS ARE NOT RECOMMENDED, AUTHORIZED OR WARRANTED FOR USE IN MILITARY, AIR CRAFT, SPACE, LIFE SAVING, OR LIFE SUSTAINING APPLICATIONS, NOR IN PRODUCTS OR SYSTEMS WHERE FAILURE OR MALFUNCTION MAY RESULT IN PERSONAL INJURY, DEATH, OR SEVERE PROPERTY OR ENVIRONMENTAL DAMAGE. ST PRODUCTS WHICH ARE NOT SPECIFIED AS "AUTOMOTIVE GRADE" MAY ONLY BE USED IN AUTOMOTIVE APPLICATIONS AT USER'S OWN RISK.

Resale of ST products with provisions different from the statements and/or technical features set forth in this document shall immediately void any warranty granted by ST for the ST product or service described herein and shall not create or extend in any manner whatsoever, any liability of ST.

ST and the ST logo are trademarks or registered trademarks of ST in various countries.

Information in this document supersedes and replaces all information previously supplied.

The ST logo is a registered trademark of STMicroelectronics. All other names are the property of their respective owners.

© 2007 STMicroelectronics - All rights reserved

STMicroelectronics group of companies

Australia - Belgium - Brazil - Canada - China - Czech Republic - Finland - France - Germany - Hong Kong - India - Israel - Italy - Japan - Malaysia - Malta - Morocco - Singapore - Spain - Sweden - Switzerland - United Kingdom - United States of America

www.st.com