

## **Excellent Integrated System Limited**

Stocking Distributor

Click to view price, real time Inventory, Delivery & Lifecycle Information:

[Rohm Semiconductor](#)  
[BA6283N](#)

For any questions, you can email us directly:

[sales@integrated-circuit.com](mailto:sales@integrated-circuit.com)

## BA6283N / BA6955N

Motor driver ICs

# Reversible motor driver

## BA6283N / BA6955N

The BA6283N and BA6955N are reversible-motor drivers with a maximum output current of 1.0A. Two logic inputs allow four output modes: forward, reverse, stop (standby), and brake.

The built-in power save circuit suppresses current consumption in the motor stop mode.

### ●Applications

VCRs, audio devices

### ●Features

- 1) Logic and driver sections have separate ground pins; this allows the IC to drive speed-variable, reversible motors by connecting an electronic governor circuit.
- 2) Built-in power saving circuit suppresses current consumption in stop (standby) mode.
- 3) Interfaces with TTL devices.
- 4) Built-in thermal shutdown circuit.

### ●Absolute maximum ratings (Ta = 25°C)

Parameter	Symbol	Limits	Unit
Applied voltage	V <sub>CC</sub>	18	V
Power dissipation	BA6283N	Pd	mW
	BA6955N		
		1080* <sup>2</sup>	
Operating temperature	T <sub>opr</sub>	-20~+75	°C
Storage temperature	T <sub>stg</sub>	-55~+150	°C
Output current	I <sub>OUT</sub>	1000* <sup>3</sup>	mA

\*1 Reduced by 9.2mW for each increase in Ta of 1°C over 25°C.

\*2 Reduced by 8.64mW for each increase in Ta of 1°C over 25°C.

\*3 Should not exceed Pd or ASO values.

### ●Recommended operating conditions (Ta = 25°C)

Parameter	Symbol	Min.	Typ.	Max.	Unit
Operating power supply voltage	V <sub>CC</sub>	5.5	–	15	V
	V <sub>M</sub>	5.5	–	15	V

**BA6283N / BA6955N**

**Motor driver ICs**

●Block diagram

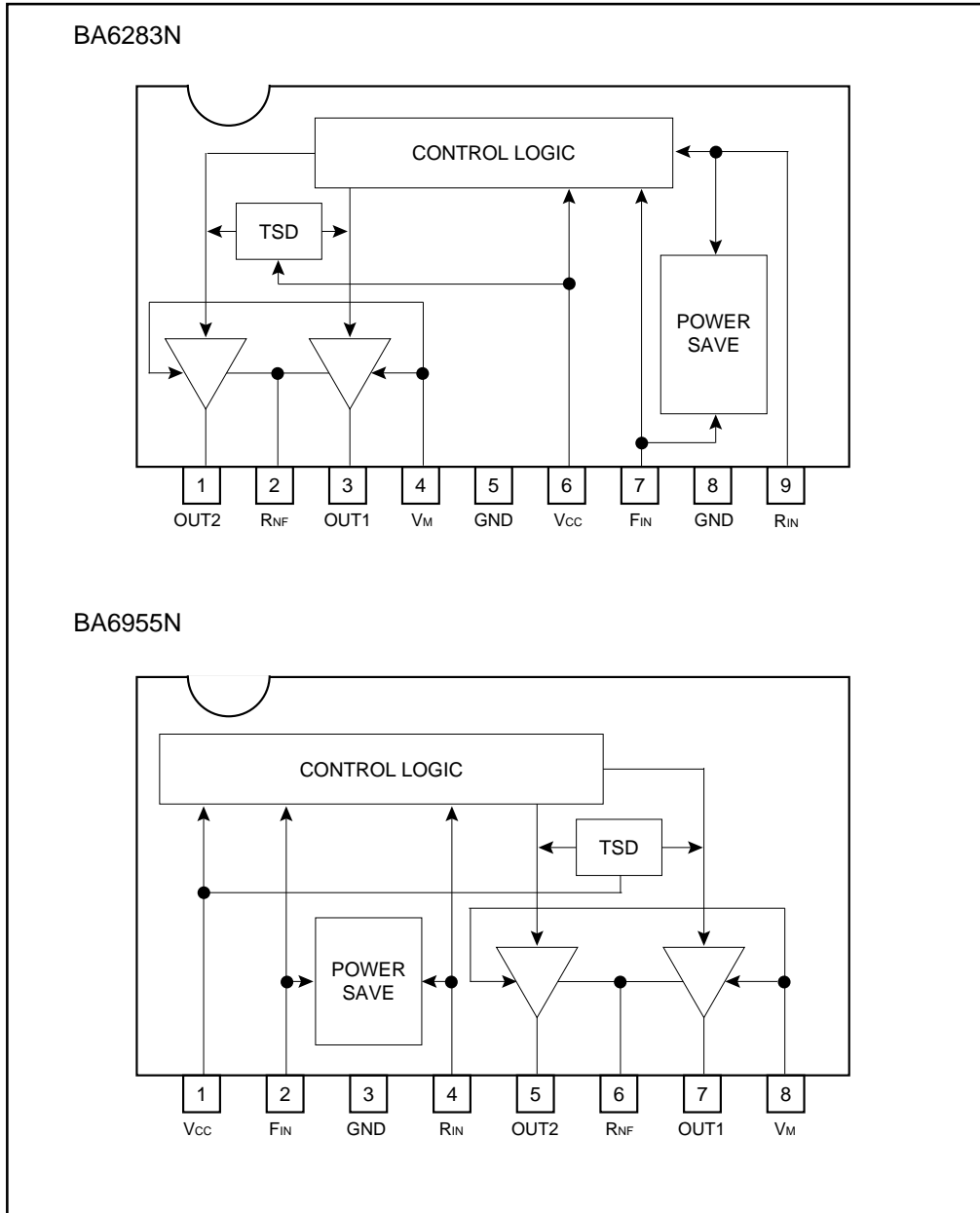

**BA6283N / BA6955N**

**Motor driver ICs**

**●Pin descriptions**

**BA6283N**

Pin No.	Pin name	Functions
1	OUT2	Motor output
2	R <sub>NF</sub>	Output GND, for connecting resistor for output current detection
3	OUT1	Motor output
4	V <sub>M</sub>	Motor power supply
5	GND	GND
6	V <sub>CC</sub>	Power supply
7	F <sub>IN</sub>	Logic input
8	GND	GND
9	R <sub>IN</sub>	Logic input

**BA6955N**

Pin No.	Pin name	Functions
1	V <sub>CC</sub>	Power supply
2	F <sub>IN</sub>	Logic input
3	GND	GND
4	R <sub>IN</sub>	Logic input
5	OUT2	Motor output
6	R <sub>NF</sub>	Output GND, for connecting resistor for output current detection
7	OUT1	Motor output
8	V <sub>M</sub>	Motor power supply

**●Input / Output circuit**

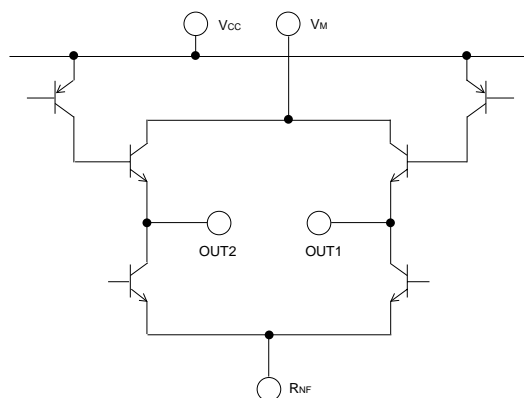

Fig.1

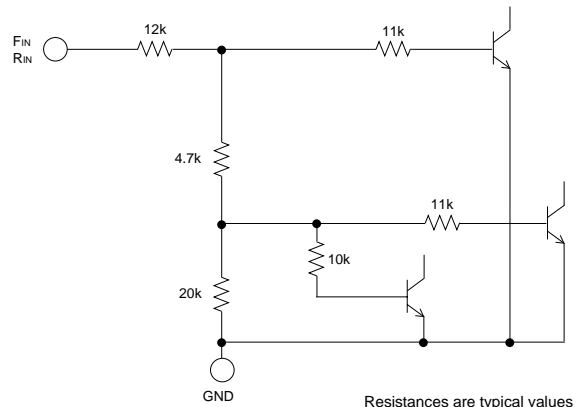

Fig.2

**BA6283N / BA6955N**

**Motor driver ICs**

**●Electrical characteristics** (unless otherwise noted, Ta=25°C, Vcc=9V, and Vm=9V)

Parameter	Symbol	Min.	Typ.	Max.	Unit	Conditions
Circuit current1	I <sub>cc1</sub>	–	30	43.5	mA	Forward or reverse mode
Circuit current2	I <sub>cc2</sub>	–	40	58	mA	Brake mode
Circuit current3	I <sub>cc3</sub>	–	–	15	μA	Standby mode
Input high level voltage	V <sub>IH</sub>	2.0	–	–	V	–
Input low level voltage	V <sub>IL</sub>	–	–	0.8	V	–
Input high level current	I <sub>IH</sub>	50	90	130	μA	V <sub>IN</sub> =2.0V
Output saturation voltage	V <sub>CE</sub>	–	1.0	1.5	V	I <sub>o</sub> =200mA Sum of the high and low side output transistor voltages

○ Not designed for radiation resistance.

**●Measuring circuits**

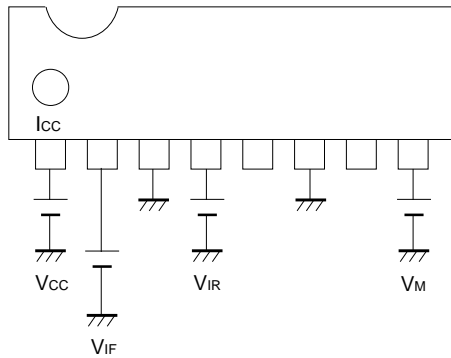

Fig.3

\*Refer to the Input/Output truth table about the output mode.

Circuit current : I<sub>cc</sub>

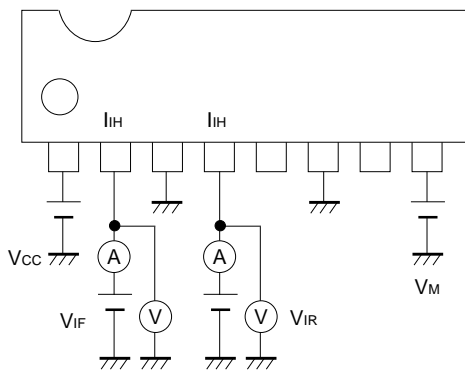

Fig.4

Input high level voltage, Input low level voltage

: V<sub>IF</sub>, V<sub>IR</sub>

\*Refer to the Input/Output truth table about the output mode.

Input high level current

: I<sub>IH</sub> at V<sub>IF</sub>=2V, I<sub>IH</sub> at V<sub>IR</sub>=2V

**BA6283N / BA6955N**

**Motor driver ICs**

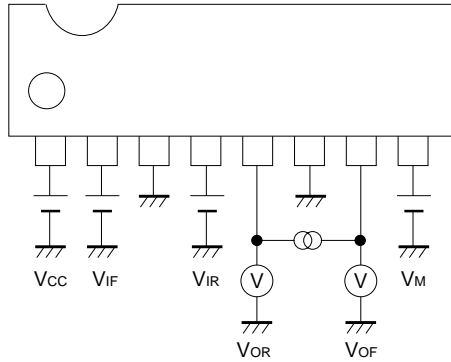

Fig.5

$V_{CE}$  : Sum of the high and low side output transistor voltage.

$I_o$  flows from High to Low Level output pins.

**●Circuit operations**

(1) Input section ( $F_{IN}$ ,  $R_{IN}$ )

Control signals are input from these pins. Input circuit can be controlled with TTL or over voltage input.

Operation in each mode is show below.

Output current flows from OUT1 to OUT2 (forward mode) when  $F_{IN}$  is High and  $R_{IN}$  is Low, and from OUT2 to OUT1 (reverse mode) when  $R_{IN}$  is Low and  $R_{IN}$  is High. Putting  $F_{IN}$  and  $R_{IN}$  both High result in the brake mode. In this mode, the high-side output transistor is turned off to shut down the motor driving current and the low-side output transistor is turned on to absorb the counter-electromotive force of the motor. When  $F_{IN}$  and  $R_{IN}$  are both Low, both OUT1 and OUT2 are left open and the motor stops. In this mode the power save circuit turn to active, and whole the IC circuit off cause the circuit current to minimize.

Input / output truth table

$F_{IN}$	$R_{IN}$	OUT1	OUT2	Mode
H	L	H	L	Forward
L	H	L	H	Reverse
H	H	L	L	Brake
L	L	OPEN	OPEN	Standby

(2) Output section (OUT1, OUT2)

Two logic inputs control the motor by changing the status of the bridge-configured transistors.

(3) Power supply section ( $V_{CC}$ ,  $V_M$ )

$V_{CC}$  is a logic Power supply terminal, and  $V_M$  is a Motor Power supply terminal.

(4) Thermal shut down (TSD)

When the IC internal temperature rises by the accident motor locked, the thermal shut down circuit is activated and all the outputs turn off with regardless of input mode. Then, the temperature falls and the thermal shut down circuit is disactivated, the output returns with regard of the input mode.

This circuit is activated when the IC junction temperature rises above 175°C (Typ.) and disabled when it is 150°C (Typ.).

(5) Power save circuit

When  $F_{IN}$  and  $R_{IN}$  are both Low, all the IC circuit turns off and it decrease the IC consumption current.

**BA6283N / BA6955N**

**Motor driver ICs**

(6) Ground (GND, R<sub>NF</sub>)

Attached the current detection resistors at the R<sub>NF</sub> terminal, the current flowing in the motor can be detected. Also attached the electronic governor, the speed-variable reversible motors can be constructed.

●Application example

BA6238N

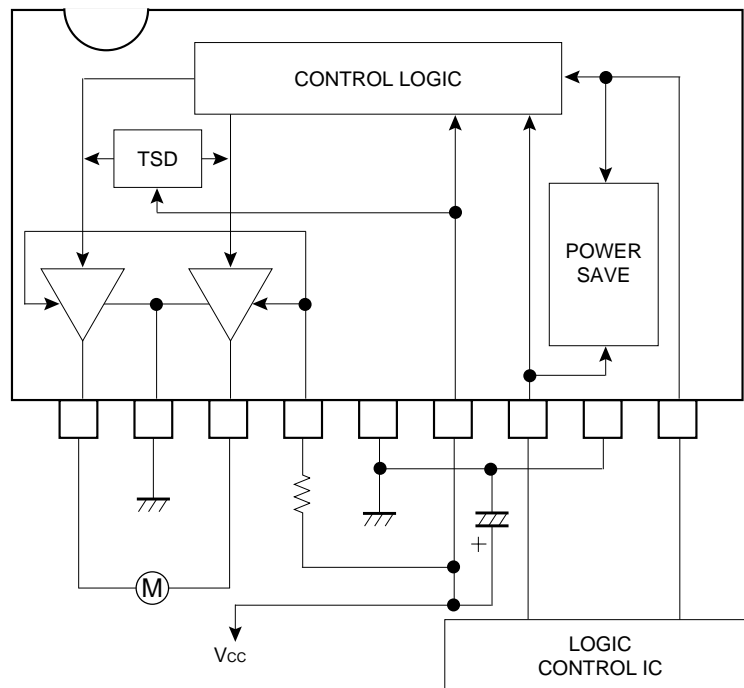
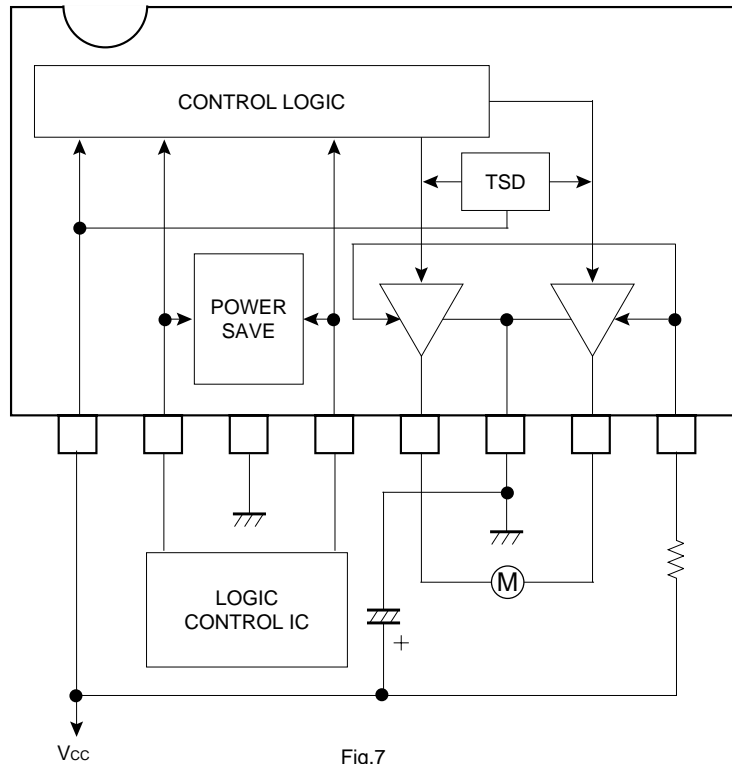

Fig.6

**BA6283N / BA6955N**

**Motor driver ICs**

BA6955N



**●Operation notes**

- (1) The quality of these products have been carefully checked; however, use of the products with applied voltages, operating temperatures, or other parameters that exceed the absolute maximum rating given may result in the damage of the IC and the product it is used in. If the IC is damaged, the short mode and open modes cannot be specified, so if the IC is to be used in applications where parameters may exceed the absolute maximum ratings, then be sure to incorporate fuses, or other physical safety measures.
- (2) GND potential  
The potential for GND pin must be kept lower than the potentials of the other pins regardless of the circumstances.
- (3) Input pins  
Voltage should never be supplied to the input pins when the  $V_{CC}$  voltage is not applied to the IC. Similarly, when  $V_{CC}$  is applied, the voltage on each input pin should be less than  $V_{CC}$  and within the guaranteed range for the electrical characteristics.
- (4) Back-rush voltage  
Depending on the ambient conditions, environment, or motor characteristics, the back-rush voltage may fluctuate. Be sure to confirm that the back-rush voltage will not adversely affect the operation of the IC.



## BA6283N / BA6955N

### Motor driver ICs

(5) Large current line

Large currents are carried by the motor power supply and motor ground for these ICs. Therefore, the layout of the pattern of the PC board and the constants of certain parameters for external components, such as the capacitor between the power supply and ground, may cause this large output current to flow back to the input pins, resulting in output oscillation or other malfunctions. To prevent this, make sure that the PC board layout and external circuit constants cause no problems with the characteristics of these ICs.

(6) Power dissipation

The power dissipation will fluctuate depending on the mounted conditions of the IC and the ambient environment. Make sure to carefully check the thermal design of the application where these ICs will be used.

(7) Power consumption

The power consumption by the IC varies widely with the power supply voltage and the output current. Give full consideration to the power dissipation rating and the thermal resistance data and transient thermal resistance data, to provide a thermal design so that none of the ratings for the IC are exceeded.

(8) ASO

Make sure that the output current and supply voltage do not exceed the ASO values.

(9) Precautions for input mode switching

To ensure reliability, it is recommended that the mode switching for the motor pass once through the open mode.

(10) Rush current

There are no circuits built into these ICs that prevent rush currents. Therefore, it is recommended to place a current limiting resistor or other physical countermeasure.

(11) Factors regarding the thermal, power supply, and motor conditions. If the potential of the output pin sways greatly and goes below the potential of ground, the operation of the IC may malfunction or be adversely affected. In such a case, place a diode between the output and ground, or other countermeasure, to prevent this.

(12) Input pins ( $F_{IN}$  and  $R_{IN}$ ) thermal characteristics

The  $F_{IN}$  and  $R_{IN}$  pins have thermal characteristics. Take these thermal characteristics into consideration when using the IC.

(13) Thermal shutdown circuit (TSD)

When the junction temperature reaches approximately 170°C (Typ.) during operation, the driver outputs are all turned off.

There is an approximate 20°C (Typ.) thermal hysteresis.

(14) Motor noise

To eliminate motor noise, connect a capacitor between OUT1 and GND and between OUT2 and GND. Alternatively, connect a capacitor between OUT1 and OUT2, and also a diode between OUT1 and GND and between OUT2 and GND (see the figure below).

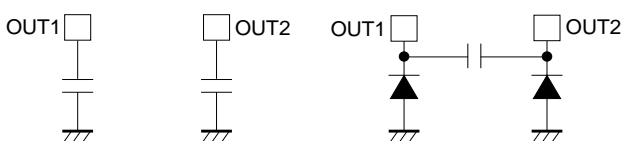

**BA6283N / BA6955N**

**Motor driver ICs**

● **Electrical characteristic curves**

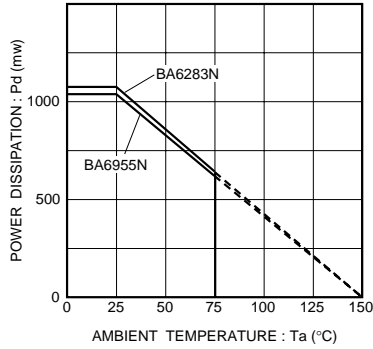

Fig.8 Package thermal derating characteristics

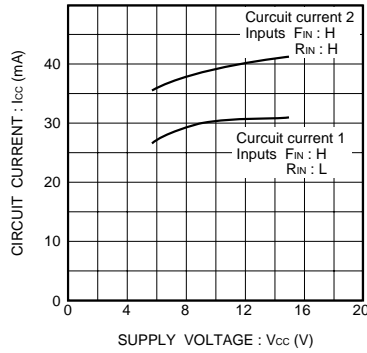

Fig.9 Circuit current vs. power supply voltage

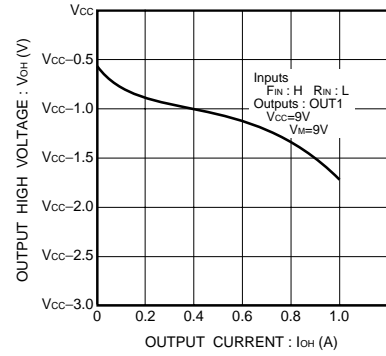

Fig.10 Output high level voltage vs. output current

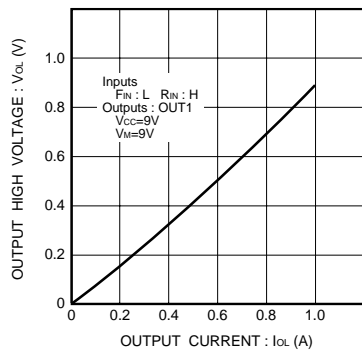

Fig.11 Output low level voltage vs. output current

● **External dimensions (Units : mm)**

