

## Excellent Integrated System Limited

Stocking Distributor

Click to view price, real time Inventory, Delivery & Lifecycle Information:

[ON Semiconductor](#)  
[MC100EP16VSDT](#)

For any questions, you can email us directly:

[sales@integrated-circuit.com](mailto:sales@integrated-circuit.com)

# MC100EP16VS

## 3.3 V / 5 V ECL Differential Receiver/Driver with Variable Output Swing

### Description

The MC100EP16VS is a differential receiver with variable output amplitude. The device is functionally equivalent to the 100EP16 with an input pin that controls the amplitude of the outputs.

The  $V_{CTRL}$  input pin controls the output amplitude of the EP16VS and is referenced to  $V_{CC}$ . (See Figure 4.) The operational range of the  $V_{CTRL}$  input is from  $\leq V_{BB}$  (max output amplitude) to  $V_{CC}$  (min output amplitude) (See Figure 3). A variable resistor between the  $V_{CC}$  and  $V_{BB}$  pins, with the wiper driving  $V_{CTRL}$ , can control the output amplitude. Typical application circuits and a  $V_{CTRL}$  Voltage vs. Output Amplitude graph are described in this data sheet. When left open, the  $V_{CTRL}$  pin will be internally pulled down to  $V_{EE}$  and operate as a standard EP16, with 100% output amplitude.

The  $V_{BB}$  pin, an internally generated voltage supply, is available to this device only. For Single-Ended input conditions, the unused differential input is connected to  $V_{BB}$  as a switching reference voltage.  $V_{BB}$  may also rebias AC coupled inputs. When used, decouple  $V_{BB}$  and  $V_{CC}$  via a 0.01  $\mu$ F capacitor and limit current sourcing or sinking to 0.5 mA. When not used,  $V_{BB}$  should be left open.

### Features

- 220 ps Propagation Delay
- Maximum Frequency = > 4 GHz Typical (See Graph)
- The 100 Series Contains Temperature Compensation
- PECL Mode Operating Range:  
 $V_{CC} = 3.0\text{ V to }5.5\text{ V with }V_{EE} = 0\text{ V}$
- NECL Mode Operating Range:  
 $V_{CC} = 0\text{ V with }V_{EE} = -3.0\text{ V to }-5.5\text{ V}$
- Open Input Default State
- Q Output Will Default LOW with Inputs Open or at  $V_{EE}$
- These Devices are Pb-Free, Halogen Free and are RoHS Compliant



ON Semiconductor®

[www.onsemi.com](http://www.onsemi.com)

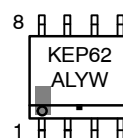


SOIC-8 NB  
 D SUFFIX  
 CASE 751-07

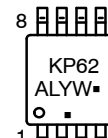


TSSOP-8  
 DT SUFFIX  
 CASE 948R-02

### MARKING DIAGRAMS\*



SOIC-8 NB



TSSOP-8

- A = Assembly Location
- L = Wafer Lot
- Y = Year
- W = Work Week
- M = Date Code
- = Pb-Free Package

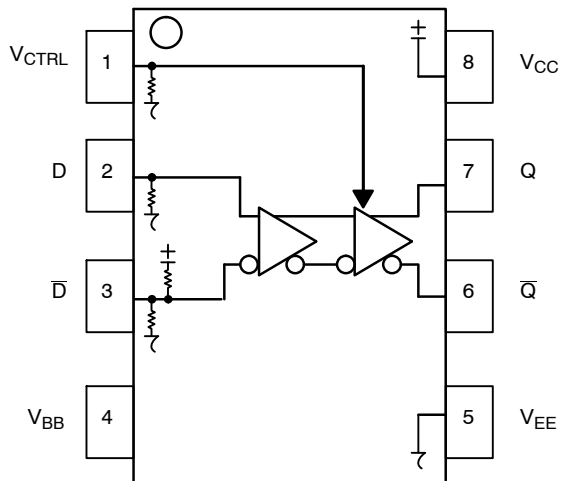
(Note: Microdot may be in either location)  
 \*For additional marking information, refer to Application Note [AND8002/D](#).

### ORDERING INFORMATION

| Device           | Package             | Shipping†        |
|------------------|---------------------|------------------|
| MC100EP16VSDG    | SOIC-8 NB (Pb-Free) | 98 Units / Tube  |
| MC100EP16VSDR2G  | SOIC-8 NB (Pb-Free) | 2500 Tape & Reel |
| MC100EP16VSDTG   | TSSOP-8 (Pb-Free)   | 100 Units / Tube |
| MC100EP16VSDTR2G | TSSOP-8 (Pb-Free)   | 2500 Tape & Reel |

†For information on tape and reel specifications, including part orientation and tape sizes, please refer to our Tape and Reel Packaging Specifications Brochure, [BRD8011/D](#).

### MC100EP16VS



**Table 1. PIN DESCRIPTION**

| PIN                 | FUNCTION                 |      |
|---------------------|--------------------------|------|
| D*, D**             | ECL Data Inputs          | 2, 3 |
| Q, Q̄               | ECL Data Outputs         | 6, 7 |
| V <sub>CTRL</sub> * | Output Swing Control     | 1    |
| V <sub>BB</sub>     | Reference Voltage Output |      |
| V <sub>CC</sub>     | Positive Supply          | 8    |
| V <sub>EE</sub>     | Negative Supply          | 5    |
| NC                  | No Connect               |      |

\* Pins will default LOW when left open.

\*\* Pins will default to V<sub>CC</sub>/2 when left open.

**Figure 1. 8-Lead Pinout (Top View) and Logic Diagram**

**Table 2. ATTRIBUTES**

| Characteristics   | Value  |
|---|--|
| Internal Input Pulldown Resistor  | 75 kΩ  |
| Internal Input Pullup Resistor  | 37.5 kΩ  |
| ESD Protection<br>Human Body Model<br>Machine Model<br>Charged Device Model | > 4 kV<br>> 200 V<br>> 2 kV                    |
| Moisture Sensitivity, Indefinite Time Out of Drypack (Note 1)               | Pb-Free Pkg                                    |
| SOIC-8 NB<br>TSSOP-8  | Level 1<br>Level 3                             |
| Flammability Rating   | Oxygen Index: 28 to 34<br>UL 94 V-0 @ 0.125 in |
| Transistor Count  | 140 Devices                                    |
| Meets or exceeds JEDEC Spec EIA/JESD78 IC Latchup Test                      |  |

1. For additional information, see Application Note [AND8003/D](#).

## MC100EP16VS

**Table 3. MAXIMUM RATINGS**

| Symbol        | Parameter  | Condition 1                                    | Condition 2                            | Rating             | Unit                        |
|---------------|--|--|--|--------------------|-----------------------------|
| $V_{CC}$      | PECL Mode Power Supply                             | $V_{EE} = 0\text{ V}$                          |  | 6                  | V                           |
| $V_{EE}$      | NECL Mode Power Supply                             | $V_{CC} = 0\text{ V}$                          |  | -6                 | V                           |
| $V_I$         | PECL Mode Input Voltage<br>NECL Mode Input Voltage | $V_{EE} = 0\text{ V}$<br>$V_{CC} = 0\text{ V}$ | $V_I \leq V_{CC}$<br>$V_I \geq V_{EE}$ | 6<br>-6            | V                           |
| $I_{out}$     | Output Current                                     | Continuous<br>Surge                            |  | 50<br>100          | mA                          |
| $I_{BB}$      | $V_{BB}$ Sink/Source                               |  |  | $\pm 0.5$          | mA                          |
| $T_A$         | Operating Temperature Range                        |  |  | -40 to +85         | $^{\circ}\text{C}$          |
| $T_{stg}$     | Storage Temperature Range                          |  |  | -65 to +150        | $^{\circ}\text{C}$          |
| $\theta_{JA}$ | Thermal Resistance (Junction-to-Ambient)           | 0 lfpm<br>500 lfpm                             | SOIC-8 NB<br>SOIC-8 NB                 | 190<br>130         | $^{\circ}\text{C}/\text{W}$ |
| $\theta_{JC}$ | Thermal Resistance (Junction-to-Case)              | Standard Board                                 | SOIC-8 NB                              | 41 to 44           | $^{\circ}\text{C}/\text{W}$ |
| $\theta_{JA}$ | Thermal Resistance (Junction-to-Ambient)           | 0 lfpm<br>500 lfpm                             | TSSOP-8<br>TSSOP-8                     | 185<br>140         | $^{\circ}\text{C}/\text{W}$ |
| $\theta_{JC}$ | Thermal Resistance (Junction-to-Case)              | Standard Board                                 | TSSOP-8                                | 41 to 44 $\pm 5\%$ | $^{\circ}\text{C}/\text{W}$ |
| $T_{sol}$     | Wave Solder (Pb-Free)                              | < 2 to 3 sec @ 260 $^{\circ}\text{C}$          |  | 265                | $^{\circ}\text{C}$          |

Stresses exceeding those listed in the Maximum Ratings table may damage the device. If any of these limits are exceeded, device functionality should not be assumed, damage may occur and reliability may be affected.

## MC100EP16VS

**Table 4. DC CHARACTERISTICS, PECL** ( $V_{CC} = 3.3\text{ V}$ ,  $V_{EE} = 0\text{ V}$  (Note 1))

| Symbol      | Characteristic  | -40°C       |           |          | 25°C        |           |          | 85°C        |      |          | Unit          |
|-------------|---|-------------|-----------|----------|-------------|-----------|----------|-------------|------|----------|---------------|
|             |   | Min         | Typ       | Max      | Min         | Typ       | Max      | Min         | Typ  | Max      |               |
| $I_{EE}$    | Power Supply Current  | 30          | 36        | 42       | 31          | 38        | 44       | 32          | 40   | 48       | mA            |
| $V_{OH}$    | Output HIGH Voltage (Max Swing)<br>(Note 2)<br>$V_{CC} \geq V_{CTRL} \geq V_{EE}$ | 2155        |           | 2405     | 2155        |           | 2405     | 2155        |      | 2405     | mV            |
| $V_{OL}$    | Output LOW Voltage (Max Swing)<br>(Note 2)<br>$V_{CTRL} \leq V_{BB}$              | 1355        | 1490      | 1605     | 1355        | 1520      | 1605     | 1355        | 1520 | 1605     | mV            |
|             | $V_{CC} \geq V_{CTRL} > V_{BB}$   |             | See Fig.2 |          |             | See Fig.2 |          | See Fig.2   |      |          |               |
|             | $V_{CTRL} = V_{CC}$ (Min Swing)   | 2105        | 2230      | 2355     | 2095        | 2220      | 2345     | 2065        | 2190 | 2315     |               |
| $V_{IH}$    | D, $\bar{D}$ Input HIGH Voltage (Single-Ended)                                    | 2075        |           | 2420     | 2075        |           | 2420     | 2075        |      | 2420     | mV            |
| $V_{IL}$    | D, $\bar{D}$ Input LOW Voltage (Single-Ended)                                     | 1355        |           | 1675     | 1355        |           | 1675     | 1355        |      | 1675     | mV            |
| $V_{BB}$    | Output Voltage Reference  | 1805        | 1905      | 2005     | 1805        | 1905      | 2005     | 1805        | 1905 | 2005     | mV            |
| $V_{CTRL}$  | Input Voltage ( $V_{CTRL}$ )  | $V_{EE}$    |           | $V_{CC}$ | $V_{EE}$    |           | $V_{CC}$ | $V_{EE}$    |      | $V_{CC}$ | mV            |
| $V_{IHCMR}$ | Input HIGH Voltage Common Mode Range (Differential Configuration) (Note 3)        | 2.0         |           | 2.9      | 2.0         |           | 2.9      | 2.0         |      | 2.9      | V             |
| $I_{IH}$    | Input HIGH Current  |             |           | 150      |             |           | 150      |             |      | 150      | $\mu\text{A}$ |
| $I_{IL}$    | Input LOW Current   |             |           |          |             |           |          |             |      |          | $\mu\text{A}$ |
|             | D<br>$\bar{D}$  | 0.5<br>-150 |           |          | 0.5<br>-150 |           |          | 0.5<br>-150 |      |          |               |

NOTE: Device will meet the specifications after thermal equilibrium has been established when mounted in a test socket or printed circuit board with maintained transverse airflow greater than 500 lpm. Electrical parameters are guaranteed only over the declared operating temperature range. Functional operation of the device exceeding these conditions is not implied. Device specification limit values are applied individually under normal operating conditions and not valid simultaneously.

1. Input and output parameters vary 1:1 with  $V_{CC}$ .  $V_{EE}$  can vary +0.3 V to -2.2 V.
2. All loading with 50  $\Omega$  to  $V_{CC} - 2.0\text{ V}$ .  $V_{OH}$  does not change with  $V_{CTRL}$ .  $V_{OL}$  changes with  $V_{CTRL}$ .  $V_{CTRL}$  is referenced to  $V_{CC}$ .
3.  $V_{IHCMR}$  min varies 1:1 with  $V_{EE}$ .  $V_{IHCMR}$  max varies 1:1 with  $V_{CC}$ . The  $V_{IHCMR}$  range is referenced to the most positive side of the differential input signal.

## MC100EP16VS

**Table 5. DC CHARACTERISTICS, PECL** ( $V_{CC} = 5.0\text{ V}$ ,  $V_{EE} = 0\text{ V}$  (Note 1))

| Symbol      | Characteristic   | -40°C       |           |          | 25°C        |           |          | 85°C        |      |          | Unit          |
|-------------|--|-------------|-----------|----------|-------------|-----------|----------|-------------|------|----------|---------------|
|             |  | Min         | Typ       | Max      | Min         | Typ       | Max      | Min         | Typ  | Max      |               |
| $I_{EE}$    | Power Supply Current   | 30          | 36        | 42       | 31          | 38        | 44       | 32          | 40   | 48       | mA            |
| $V_{OH}$    | Output HIGH Voltage (Note 2)<br>$V_{CC} > V_{CTRL} > V_{EE}$               | 3855        | 3980      | 4105     | 3855        | 3980      | 4105     | 3855        | 3980 | 4105     | mV            |
| $V_{OL}$    | Output LOW Voltage (Max Swing)<br>(Note 2)<br>$V_{CTRL} \leq V_{BB}$       | 3055        | 3190      | 3305     | 3055        | 3220      | 3305     | 3055        | 3220 | 3305     | mV            |
|             | $V_{CC} \geq V_{CTRL} > V_{BB}$  |             | See Fig.2 |          |             | See Fig.2 |          | See Fig.2   |      |          |               |
|             | $V_{CTRL} = V_{CC}$ (Min Swing)  | 3805        | 3930      | 4055     | 3795        | 3920      | 4045     | 3765        | 3890 | 4015     |               |
| $V_{IH}$    | D, $\bar{D}$ Input HIGH Voltage (Single-Ended)                             | 3775        |           | 4120     | 3775        |           | 4120     | 3775        |      | 4120     | mV            |
| $V_{IL}$    | D, $\bar{D}$ Input LOW Voltage (Single-Ended)                              | 3055        |           | 3375     | 3055        |           | 3375     | 3055        |      | 3375     | mV            |
| $V_{CTRL}$  | Input Voltage ( $V_{CTRL}$ )   | $V_{EE}$    |           | $V_{CC}$ | $V_{EE}$    |           | $V_{CC}$ | $V_{EE}$    |      | $V_{CC}$ | mV            |
| $V_{BB}$    | Output Voltage Reference   | 3505        | 3605      | 3705     | 3505        | 3605      | 3705     | 3505        | 3605 | 3705     | mV            |
| $V_{IHCMR}$ | Input HIGH Voltage Common Mode Range (Differential Configuration) (Note 3) | 2.0         |           | 4.6      | 2.0         |           | 4.6      | 2.0         |      | 4.6      | V             |
| $I_{IH}$    | Input HIGH Current   |             |           | 150      |             |           | 150      |             |      | 150      | $\mu\text{A}$ |
| $I_{IL}$    | Input LOW Current<br>D<br>$\bar{D}$  | 0.5<br>-150 |           |          | 0.5<br>-150 |           |          | 0.5<br>-150 |      |          | $\mu\text{A}$ |

NOTE: Device will meet the specifications after thermal equilibrium has been established when mounted in a test socket or printed circuit board with maintained transverse airflow greater than 500 lfm. Electrical parameters are guaranteed only over the declared operating temperature range. Functional operation of the device exceeding these conditions is not implied. Device specification limit values are applied individually under normal operating conditions and not valid simultaneously.

1. Input and output parameters vary 1:1 with  $V_{CC}$ .  $V_{EE}$  can vary +2.0 V to -0.5 V.
2. All loading with  $50\ \Omega$  to  $V_{CC} - 2.0\text{ V}$ .  $V_{OH}$  does not change with  $V_{CTRL}$ .  $V_{OL}$  changes with  $V_{CTRL}$ .  $V_{CTRL}$  is referenced to  $V_{CC}$ .
3.  $V_{IHCMR}$  min varies 1:1 with  $V_{EE}$ ,  $V_{IHCMR}$  max varies 1:1 with  $V_{CC}$ . The  $V_{IHCMR}$  range is referenced to the most positive side of the differential input signal.

## MC100EP16VS

**Table 6. DC CHARACTERISTICS, NECL** ( $V_{CC} = 0\text{ V}$ ;  $V_{EE} = -5.5\text{ V}$  to  $-3.0\text{ V}$  (Note 1))

| Symbol      | Characteristic  | -40°C        |           |          | 25°C         |           |          | 85°C         |           |          | Unit          |
|-------------|---|--------------|-----------|----------|--------------|-----------|----------|--------------|-----------|----------|---------------|
|             |   | Min          | Typ       | Max      | Min          | Typ       | Max      | Min          | Typ       | Max      |               |
| $I_{EE}$    | Power Supply Current  | 30           | 36        | 42       | 31           | 38        | 44       | 32           | 40        | 48       | mA            |
| $V_{OH}$    | Output HIGH Voltage (Note 2)<br>$V_{CC} > V_{CTRL} > V_{EE}$                  | -1145        | -1020     | -895     | -1145        | -1020     | -895     | -1145        | -1020     | -895     | mV            |
| $V_{OL}$    | Output LOW Voltage (Max Swing)<br>(Note 2)<br>$V_{CTRL} \leq V_{BB}$          | -1945        | -1810     | -1695    | -1945        | -1780     | -1695    | -1945        | -1780     | -1695    | mV            |
|             | $V_{CC} \geq V_{CTRL} > V_{BB}$   |              | See Fig.2 |          |              | See Fig.2 |          |              | See Fig.2 |          |               |
|             | $V_{CTRL} = V_{CC}$ (Min Swing)   | -1195        | -1070     | -945     | -1205        | -1080     | -955     | -1235        | -1110     | -985     |               |
| $V_{IH}$    | D, $\bar{D}$ Input HIGH Voltage (Single-Ended)                                | -1225        |           | -880     | -1225        |           | -880     | -1225        |           | -880     | mV            |
| $V_{IL}$    | D, $\bar{D}$ Input LOW Voltage (Single-Ended)                                 | -1945        |           | -1625    | -1945        |           | -1625    | -1945        |           | -1625    | mV            |
| $V_{BB}$    | Output Voltage Reference  | -1525        | -1425     | -1325    | -1525        | -1425     | -1325    | -1525        | -1425     | -1325    | mV            |
| $V_{CTRL}$  | Input Voltage ( $V_{CTRL}$ )  | $V_{EE}$     |           | $V_{CC}$ | $V_{EE}$     |           | $V_{CC}$ | $V_{EE}$     |           | $V_{CC}$ | mV            |
| $V_{IHCMR}$ | Input HIGH Voltage Common Mode Range (Differential Configuration)<br>(Note 3) | $V_{EE}+2.0$ |           | -0.4     | $V_{EE}+2.0$ |           | -0.4     | $V_{EE}+2.0$ |           | -0.4     | V             |
| $I_{IH}$    | Input HIGH Current  |              |           | 150      |              |           | 150      |              |           | 150      | $\mu\text{A}$ |
| $I_{IL}$    | Input LOW Current<br>D<br>$\bar{D}$   | 0.5<br>-150  |           |          | 0.5<br>-150  |           |          | 0.5<br>-150  |           |          | $\mu\text{A}$ |

NOTE: Device will meet the specifications after thermal equilibrium has been established when mounted in a test socket or printed circuit board with maintained transverse airflow greater than 500 lfpm. Electrical parameters are guaranteed only over the declared operating temperature range. Functional operation of the device exceeding these conditions is not implied. Device specification limit values are applied individually under normal operating conditions and not valid simultaneously.

1. Input and output parameters vary 1:1 with  $V_{CC}$ .
2. All loading with  $50\ \Omega$  to  $V_{CC} - 2.0\text{ V}$ .  $V_{OH}$  does not change with  $V_{CTRL}$ .  $V_{OL}$  changes with  $V_{CTRL}$ .  $V_{CTRL}$  is referenced to  $V_{CC}$ .
3.  $V_{IHCMR}$  min varies 1:1 with  $V_{EE}$ ,  $V_{IHCMR}$  max varies 1:1 with  $V_{CC}$ . The  $V_{IHCMR}$  range is referenced to the most positive side of the differential input signal.

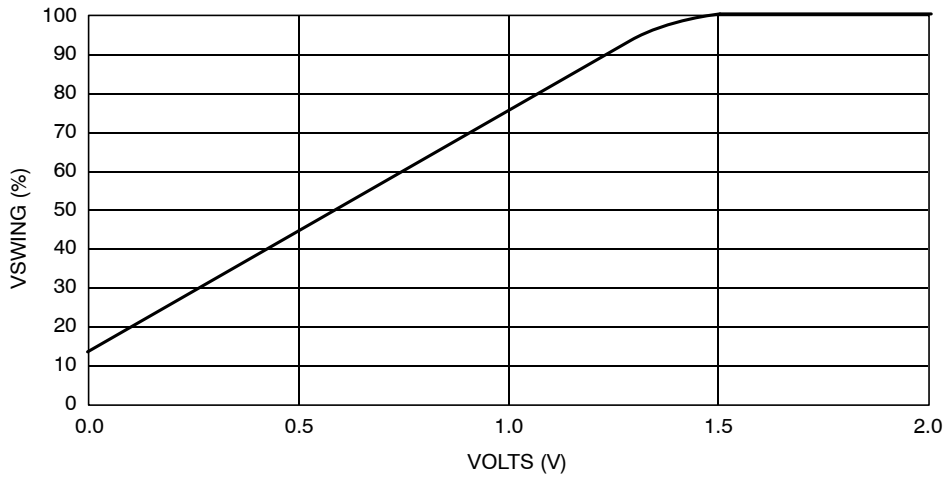
**Table 7. AC CHARACTERISTICS** ( $V_{CC} = 0\text{ V}$ ;  $V_{EE} = -3.0\text{ V}$  to  $-5.5\text{ V}$  or  $V_{CC} = 3.0\text{ V}$  to  $5.5\text{ V}$ ;  $V_{EE} = 0\text{ V}$  (Note 1))

| Symbol                   | Characteristic   | -40°C     |            |            | 25°C      |            |            | 85°C       |            |            | Unit |
|--------------------------|--|-----------|------------|------------|-----------|------------|------------|------------|------------|------------|------|
|                          |  | Min       | Typ        | Max        | Min       | Typ        | Max        | Min        | Typ        | Max        |      |
| $f_{max}$                | Maximum Toggle Frequency<br>(See Figure 6. $F_{max}/\text{JITTER}$ ) |           | > 4        |            |           | > 4        |            |            | > 4        |            | GHz  |
| $t_{PLH}$ ,<br>$t_{PHL}$ | Propagation Delay to Output Differential<br>Max Swing<br>Min Swing   | 150<br>90 | 220<br>150 | 280<br>210 | 150<br>90 | 220<br>150 | 280<br>210 | 160<br>100 | 240<br>160 | 300<br>220 | ps   |
| $t_{SKEW}$               | Duty Cycle Skew (Note 2)   |           | 5.0        | 20         |           | 5.0        | 20         |            | 5.0        | 20         | ps   |
| $t_{JITTER}$             | Cycle-to-Cycle Jitter<br>(See Figure 6. $F_{max}/\text{JITTER}$ )    |           | 0.2        | < 1        |           | 0.2        | < 1        |            | 0.2        | < 1        | ps   |
| $V_{PP}$                 | Input Voltage Swing<br>(Differential Configuration) (Note 3)         | 150       | 800        | 1200       | 150       | 800        | 1200       | 150        | 800        | 1200       | mV   |
| $t_r$<br>$t_f$           | Output Rise/Fall Times<br>(20%–80%)<br>Max Swing Q<br>Min Swing      | 70<br>30  | 120<br>80  | 170<br>130 | 80<br>20  | 130<br>70  | 180<br>120 | 100<br>20  | 150<br>70  | 200<br>120 | ps   |

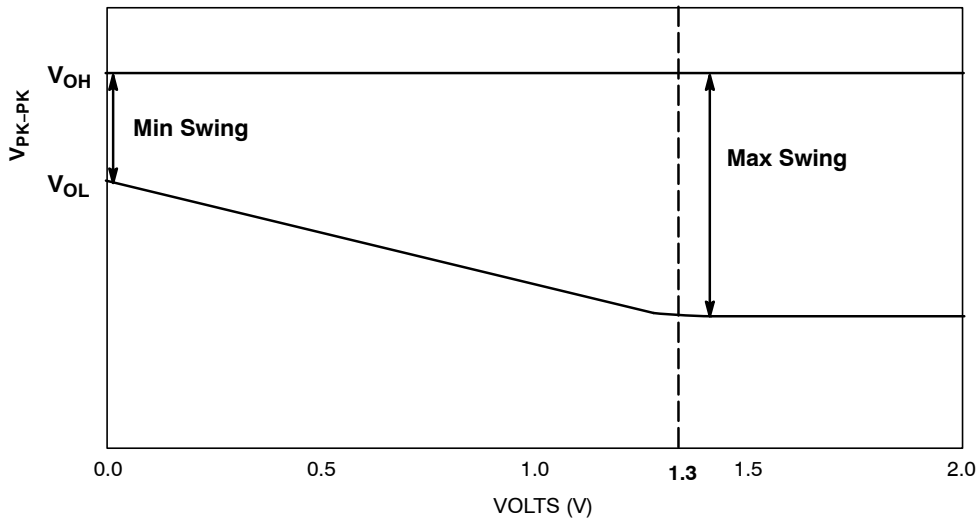
NOTE: Device will meet the specifications after thermal equilibrium has been established when mounted in a test socket or printed circuit board with maintained transverse airflow greater than 500 lfpm. Electrical parameters are guaranteed only over the declared operating temperature range. Functional operation of the device exceeding these conditions is not implied. Device specification limit values are applied individually under normal operating conditions and not valid simultaneously.

1. Measured using a 750 mV source, 50% duty cycle clock source. All loading with  $50\ \Omega$  to  $V_{CC} - 2.0\text{ V}$ .
2. Skew is measured between outputs under identical transitions. Duty cycle skew is defined only for differential operation when the delays are measured from the cross point of the inputs to the cross point of the outputs.
3.  $V_{PP}(\text{min})$  is minimum input swing for which AC parameters are guaranteed.

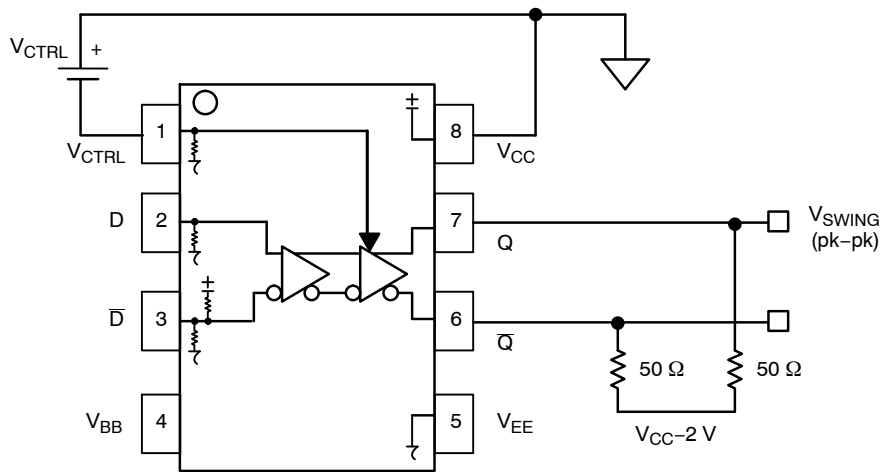
**MC100EP16VS**



**Figure 2. V<sub>CC</sub> - V<sub>CTRL</sub> (pin #1)**



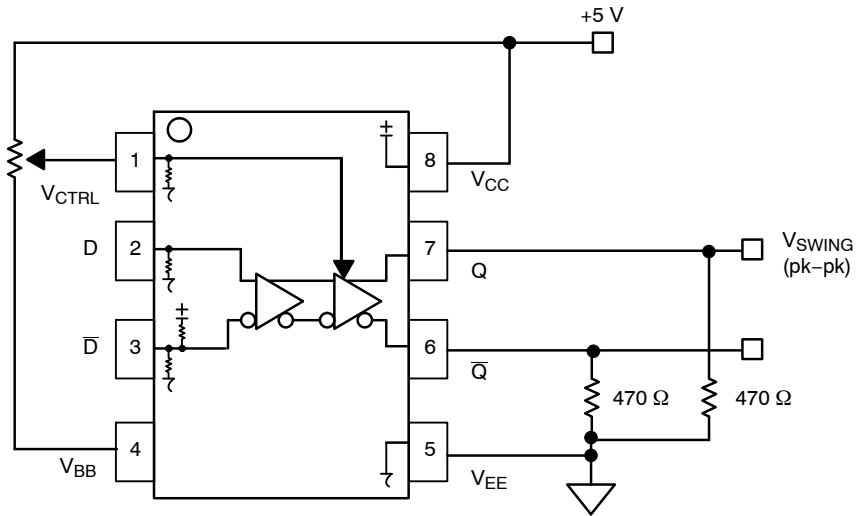
**Figure 3. V<sub>CC</sub> - V<sub>CTRL</sub>**



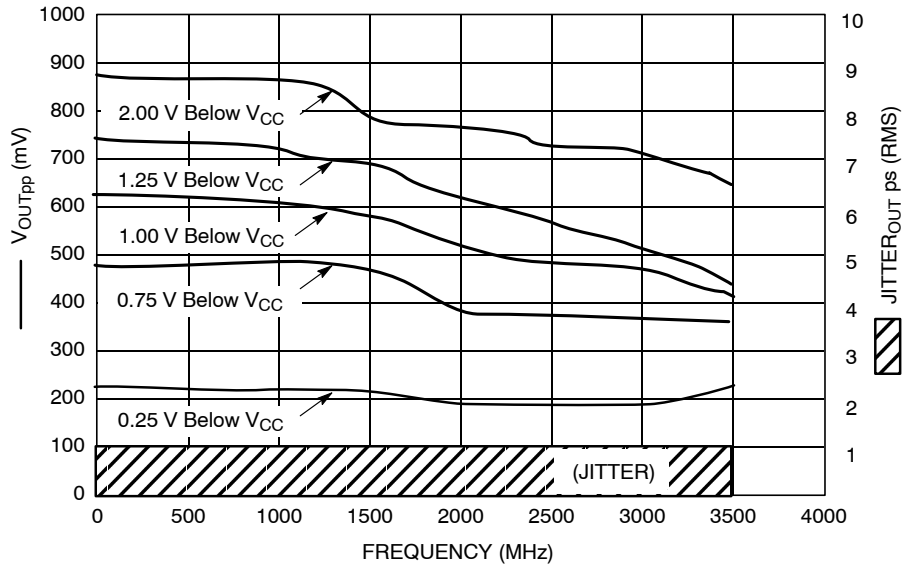
**Figure 4. Voltage Source Implementation**



**MC100EP16VS**

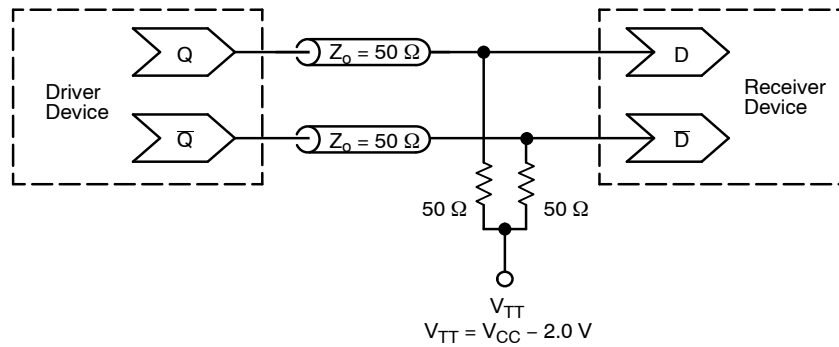


**Figure 5. Alternative Implementation**



**Figure 6. F<sub>max</sub>/Jitter**

**MC100EP16VS**



**Figure 7. Typical Termination for Output Driver and Device Evaluation**  
 (See Application Note [AND8020/D](#) – Termination of ECL Logic Devices)

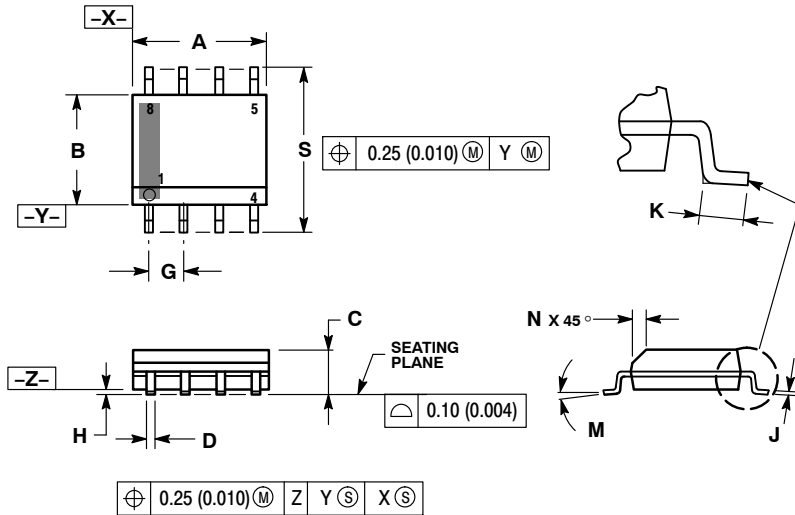
**Resource Reference of Application Notes**

- AN1405/D** – ECL Clock Distribution Techniques
- AN1406/D** – Designing with PECL (ECL at +5.0 V)
- AN1503/D** – ECLinPS™ I/O SPICE Modeling Kit
- AN1504/D** – Metastability and the ECLinPS Family
- AN1568/D** – Interfacing Between LVDS and ECL
- AN1672/D** – The ECL Translator Guide
- AND8001/D** – Odd Number Counters Design
- AND8002/D** – Marking and Date Codes
- AND8020/D** – Termination of ECL Logic Devices
- AND8066/D** – Interfacing with ECLinPS
- AND8090/D** – AC Characteristics of ECL Devices

**MC100EP16VS**

**PACKAGE DIMENSIONS**

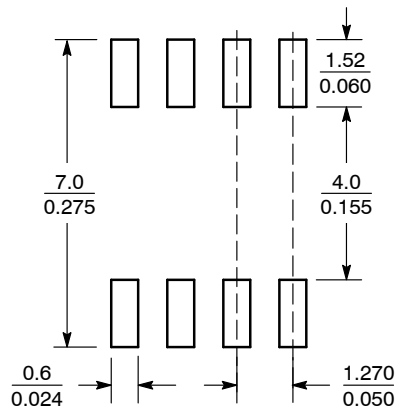
**SOIC-8 NB**  
**D SUFFIX**  
CASE 751-07  
ISSUE AK



- NOTES:
1. DIMENSIONING AND TOLERANCING PER ANSI Y14.5M, 1982.
  2. CONTROLLING DIMENSION: MILLIMETER.
  3. DIMENSION A AND B DO NOT INCLUDE MOLD PROTRUSION.
  4. MAXIMUM MOLD PROTRUSION 0.15 (0.006) PER SIDE.
  5. DIMENSION D DOES NOT INCLUDE DAMBAR PROTRUSION. ALLOWABLE DAMBAR PROTRUSION SHALL BE 0.127 (0.005) TOTAL IN EXCESS OF THE D DIMENSION AT MAXIMUM MATERIAL CONDITION.
  6. 751-01 THRU 751-06 ARE OBSOLETE. NEW STANDARD IS 751-07.

| DIM | MILLIMETERS |      | INCHES    |       |
|-----|-------------|------|-----------|-------|
|     | MIN         | MAX  | MIN       | MAX   |
| A   | 4.80        | 5.00 | 0.189     | 0.197 |
| B   | 3.80        | 4.00 | 0.150     | 0.157 |
| C   | 1.35        | 1.75 | 0.053     | 0.069 |
| D   | 0.33        | 0.51 | 0.013     | 0.020 |
| G   | 1.27 BSC    |      | 0.050 BSC |       |
| H   | 0.10        | 0.25 | 0.004     | 0.010 |
| J   | 0.19        | 0.25 | 0.007     | 0.010 |
| K   | 0.40        | 1.27 | 0.016     | 0.050 |
| M   | 0°          | 8°   | 0°        | 8°    |
| N   | 0.25        | 0.50 | 0.010     | 0.020 |
| S   | 5.80        | 6.20 | 0.228     | 0.244 |

**SOLDERING FOOTPRINT\***



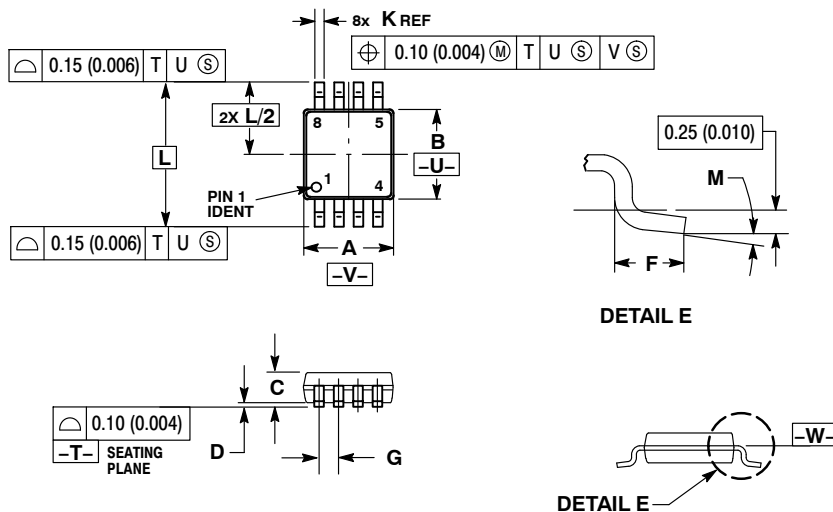
SCALE 6:1 (mm/inches)

\*For additional information on our Pb-Free strategy and soldering details, please download the ON Semiconductor Soldering and Mounting Techniques Reference Manual, SOLDERRM/D.

## MC100EP16VS

### PACKAGE DIMENSIONS

TSSOP-8  
 DT SUFFIX  
 CASE 948R-02  
 ISSUE A



- NOTES:
- DIMENSIONING AND TOLERANCING PER ANSI Y14.5M, 1982.
  - CONTROLLING DIMENSION: MILLIMETER.
  - DIMENSION A DOES NOT INCLUDE MOLD FLASH. PROTRUSIONS OR GATE BURRS. MOLD FLASH OR GATE BURRS SHALL NOT EXCEED 0.15 (0.006) PER SIDE.
  - DIMENSION B DOES NOT INCLUDE INTERLEAD FLASH OR PROTRUSION. INTERLEAD FLASH OR PROTRUSION SHALL NOT EXCEED 0.25 (0.010) PER SIDE.
  - TERMINAL NUMBERS ARE SHOWN FOR REFERENCE ONLY.
  - DIMENSION A AND B ARE TO BE DETERMINED AT DATUM PLANE -W-.

| DIM | MILLIMETERS |      | INCHES    |       |
|-----|-------------|------|-----------|-------|
|     | MIN         | MAX  | MIN       | MAX   |
| A   | 2.90        | 3.10 | 0.114     | 0.122 |
| B   | 2.90        | 3.10 | 0.114     | 0.122 |
| C   | 0.80        | 1.10 | 0.031     | 0.043 |
| D   | 0.05        | 0.15 | 0.002     | 0.006 |
| F   | 0.40        | 0.70 | 0.016     | 0.028 |
| G   | 0.65 BSC    |      | 0.026 BSC |       |
| K   | 0.25        | 0.40 | 0.010     | 0.016 |
| L   | 4.90 BSC    |      | 0.193 BSC |       |
| M   | 0°          | 6°   | 0°        | 6°    |

ECLinPS is a trademark of Semiconductor Components Industries, LLC (SCILLC) or its subsidiaries in the United States and/or other countries.

ON Semiconductor and are trademarks of Semiconductor Components Industries, LLC dba ON Semiconductor or its subsidiaries in the United States and/or other countries. ON Semiconductor owns the rights to a number of patents, trademarks, copyrights, trade secrets, and other intellectual property. A listing of ON Semiconductor's product/patent coverage may be accessed at [www.onsemi.com/site/pdf/Patent-Marketing.pdf](http://www.onsemi.com/site/pdf/Patent-Marketing.pdf). ON Semiconductor reserves the right to make changes without further notice to any products herein. ON Semiconductor makes no warranty, representation or guarantee regarding the suitability of its products for any particular purpose, nor does ON Semiconductor assume any liability arising out of the application or use of any product or circuit, and specifically disclaims any and all liability, including without limitation special, consequential or incidental damages. Buyer is responsible for its products and applications using ON Semiconductor products, including compliance with all laws, regulations and safety requirements or standards, regardless of any support or applications information provided by ON Semiconductor. "Typical" parameters which may be provided in ON Semiconductor data sheets and/or specifications can and do vary in different applications and actual performance may vary over time. All operating parameters, including "Typicals" must be validated for each customer application by customer's technical experts. ON Semiconductor does not convey any license under its patent rights nor the rights of others. ON Semiconductor products are not designed, intended, or authorized for use as a critical component in life support systems or any FDA Class 3 medical devices or medical devices with a same or similar classification in a foreign jurisdiction or any devices intended for implantation in the human body. Should Buyer purchase or use ON Semiconductor products for any such unintended or unauthorized application, Buyer shall indemnify and hold ON Semiconductor and its officers, employees, subsidiaries, affiliates, and distributors harmless against all claims, costs, damages, and expenses, and reasonable attorney fees arising out of, directly or indirectly, any claim of personal injury or death associated with such unintended or unauthorized use, even if such claim alleges that ON Semiconductor was negligent regarding the design or manufacture of the part. ON Semiconductor is an Equal Opportunity/Affirmative Action Employer. This literature is subject to all applicable copyright laws and is not for resale in any manner.

#### PUBLICATION ORDERING INFORMATION

##### LITERATURE FULFILLMENT:

Literature Distribution Center for ON Semiconductor  
 19521 E. 32nd Pkwy, Aurora, Colorado 80011 USA  
 Phone: 303-675-2175 or 800-344-3860 Toll Free USA/Canada  
 Fax: 303-675-2176 or 800-344-3867 Toll Free USA/Canada  
 Email: orderlit@onsemi.com

N. American Technical Support: 800-282-9855 Toll Free  
 USA/Canada

Europe, Middle East and Africa Technical Support:  
 Phone: 421 33 790 2910

Japan Customer Focus Center  
 Phone: 81-3-5817-1050

ON Semiconductor Website: [www.onsemi.com](http://www.onsemi.com)

Order Literature: <http://www.onsemi.com/orderlit>

For additional information, please contact your local  
 Sales Representative