

Excellent Integrated System Limited

Stocking Distributor

Click to view price, real time Inventory, Delivery & Lifecycle Information:

[STMicroelectronics](#)
[74ALVCH32245LBR](#)

For any questions, you can email us directly:

sales@integrated-circuit.com



74ALVCH32245

LOW VOLTAGE CMOS 32-BIT BUS TRANSCEIVER (3-STATE) WITH 3.6V TOLERANT AT INPUTS AND OUTPUTS

- 3.6V TOLERANT INPUTS AND OUTPUTS
- HIGH SPEED:
 $t_{PD} = 3.0ns$ (MAX.) at $V_{CC} = 3.0$ to $3.6V$
 $t_{PD} = 3.7ns$ (MAX.) at $V_{CC} = 2.3$ to $2.7V$
- POWER DOWN PROTECTION ON INPUTS AND OUTPUTS
- SYMMETRICAL OUTPUT IMPEDANCE:
 $|I_{OH}| = I_{OL} = 24mA$ (MIN) at $V_{CC} = 3V$
 $|I_{OH}| = I_{OL} = 8mA$ (MIN) at $V_{CC} = 2.3V$
- OPERATING VOLTAGE RANGE:
 $V_{CC}(OPR) = 1.65V$ to $3.6V$
- PIN AND FUNCTION COMPATIBLE WITH 74 SERIES 32245
- BUS HOLD PROVIDED ON BOTH SIDE
- LATCH-UP PERFORMANCE EXCEEDS 300mA
- ESD PERFORMANCE:
 $HBM > 2000V$ (MIL STD 883 method 3015);
 $MM > 200V$

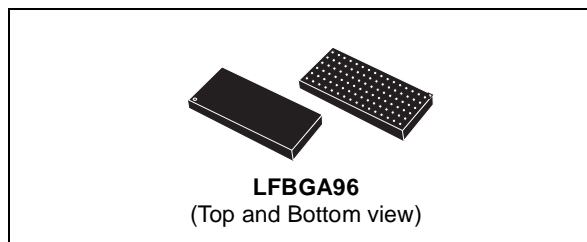

ORDER CODES

PACKAGE	TRAY	T & P
LFBGA96	74ALVCH32245LB	74ALVCH32245LBR

DESCRIPTION

The 74ALVCH32245 is a low voltage CMOS 32-BIT BUS TRANSCEIVER (3-STATE) fabricated with sub-micron silicon gate and five-layer metal wiring C²MOS technology. It is ideal for 1.65 to 3.6 V applications; it can be interfaced to 3.6V signal environment for both inputs and outputs.

This IC is intended for two-ways asynchronous communication between data buses: the direction of data transmission is determined by DIR input. Any \overline{nG} control output governs eight BUS TRANSCEIVERS. Output Enable input (\overline{nG}) tied together gives full 32-bit operation. When \overline{nG} is LOW the output are enabled. When \overline{nG} is HIGH, the output are in high impedance state so that the buses are effectively isolated. Bus hold on data inputs is provided in order to eliminate the need for external pull-up or pull-down resistor. All inputs and outputs are equipped with protection circuits against static discharge, giving them 2KV ESD immunity and transient excess voltage.

LOGIC DIAGRAM

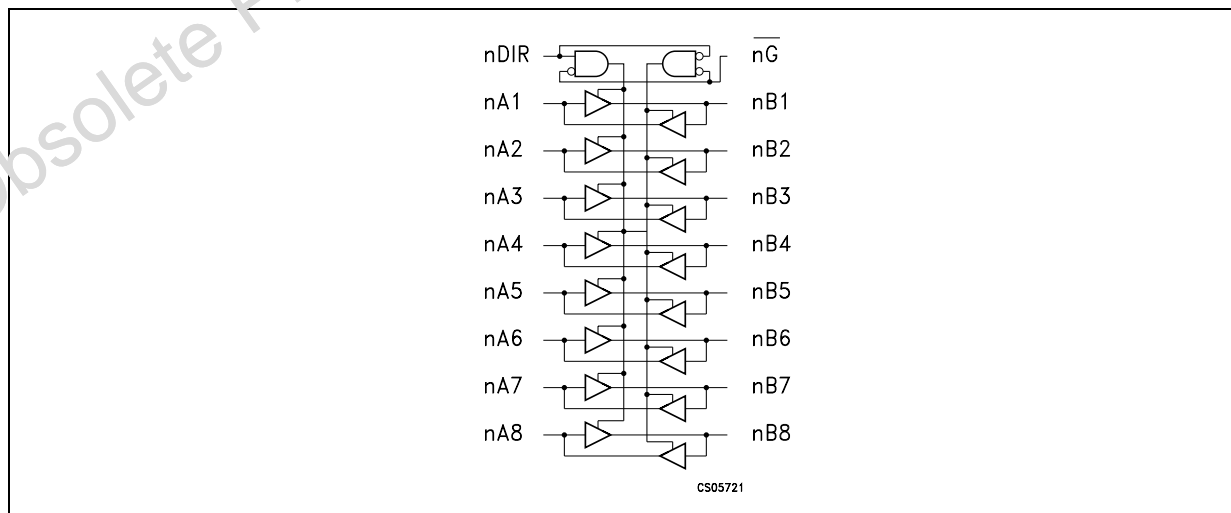

74ALVCH32245

PIN CONNECTION (Top view)

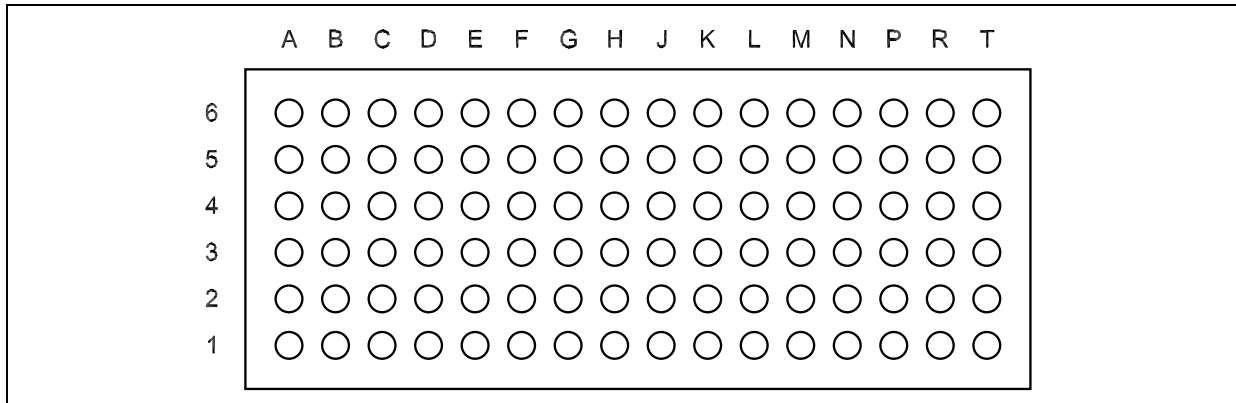

TERMINAL ASSIGNMENT

	A	B	C	D	E	F	G	H	J	K	L	M	N	P	R	T
6	1A2	1A4	1A6	1A8	2A2	2A4	2A6	2A7	3A2	3A4	3A6	3A8	4A2	4A4	4A6	4A7
5	1A1	1A3	1A5	1A7	2A1	2A3	2A5	2A8	3A1	3A3	3A5	3A7	4A1	4A3	4A5	4A8
4	$\overline{1G}$	GND	V _{CC}	GND	GND	V _{CC}	GND	$\overline{2G}$	$\overline{3G}$	GND	V _{CC}	GND	GND	V _{CC}	GND	$\overline{4G}$
3	1DIR	GND	V _{CC}	GND	GND	V _{CC}	GND	2DIR	3DIR	GND	V _{CC}	GND	GND	V _{CC}	GND	4DIR
2	1B1	1B3	1B5	1B7	2B1	2B3	2B5	2B8	3B1	3B3	3B5	3B7	4B1	4B3	4B5	4B8
1	1B2	1B4	1B6	1B8	2B2	2B4	2B6	2B7	3B2	3B4	3B6	3B8	4B2	4B4	4B6	4B7

INPUT AND OUTPUT EQUIVALENT CIRCUIT

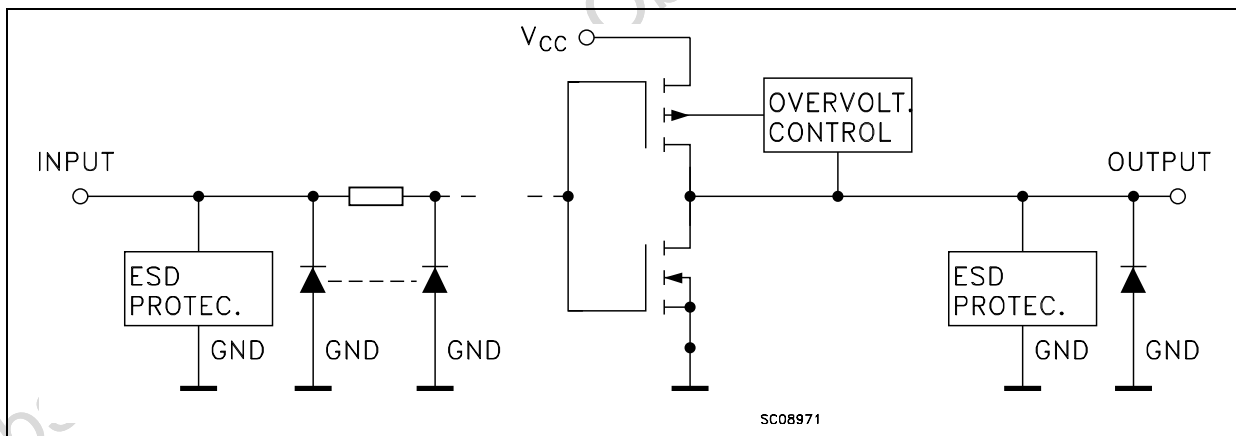

PIN DESCRIPTION

SYMBOL	NAME AND FUNCTION
nDIR	Directional Control
nA1 to nA8	Data Inputs/Outputs
nB1 to nB8	Data Inputs/Outputs
nG	Output Enable Inputs
GND	Ground (0V)
V _{CC}	Positive Supply Voltage

TRUTH TABLE

INPUTS		FUNCTION		OUTPUT
\overline{nG}	nDIR	A BUS	B BUS	Y _n
L	L	OUTPUT	INPUT	A = B
L	H	INPUT	OUTPUT	B = A
H	X	Z	Z	Z

X : Don't Care
 Z : High Impedance

74ALVCH32245

ABSOLUTE MAXIMUM RATINGS

Symbol	Parameter	Value	Unit
V_{CC}	Supply Voltage	-0.5 to +4.6	V
V_I	DC Input Voltage	-0.5 to +4.6	V
V_O	DC Output Voltage ($V_{CC} = 0V$)	-0.5 to +4.6	V
V_O	DC Output Voltage (High or Low State) (note 1)	-0.5 to $V_{CC} + 0.5$	V
I_{IK}	DC Input Diode Current	- 50	mA
I_{OK}	DC Output Diode Current (note 2)	- 50	mA
I_O	DC Output Current	± 50	mA
I_{CC} or I_{GND}	DC V_{CC} or Ground Current per Supply Pin	± 100	mA
P_D	Power Dissipation	400	mW
T_{stg}	Storage Temperature	-65 to +150	$^{\circ}C$
T_L	Lead Temperature (10 sec)	300	$^{\circ}C$

Absolute Maximum Ratings are those values beyond which damage to the device may occur. Functional operation under these conditions is not implied

- 1) I_O absolute maximum rating must be observed
 2) $V_O < GND$

RECOMMENDED OPERATING CONDITIONS

Symbol	Parameter	Value	Unit
V_{CC}	Supply Voltage (note 1)	1.65 to 3.6	V
V_I	Input Voltage	0 to 3.6	V
V_O	Output Voltage ($V_{CC} = 0V$)	0 to 3.6	V
V_O	Output Voltage (High or Low State)	0 to V_{CC}	V
I_{OH}, I_{OL}	High or Low Level Output Current ($V_{CC} = 3.0$ to $3.6V$)	± 24	mA
I_{OH}, I_{OL}	High or Low Level Output Current ($V_{CC} = 2.7V$)	± 12	mA
I_{OH}, I_{OL}	High or Low Level Output Current ($V_{CC} = 2.3$ to $2.5V$)	± 8	mA
T_{op}	Operating Temperature	-40 to +85	$^{\circ}C$
dt/dv	Input Rise and Fall Time (note 2)	0 to 10	ns/V

- 1) Truth Table guaranteed: 1.2V to 3.6V
 2) V_{IN} from 0.8V to 2V at $V_{CC} = 3.0V$

74ALVCH32245

DC SPECIFICATIONS

Symbol	Parameter	Test Condition		Value		Unit
		V _{CC} (V)		-40 to 85 °C		
				Min.	Max.	
V _{IH}	High Level Input Voltage	1.65 to 1.95		0.65V _{CC}		V
		2.3 to 2.7		1.7		
		2.7 to 3.6		2.0		
V _{IL}	Low Level Input Voltage	1.65 to 1.95			0.35V _{CC}	V
		2.3 to 2.7			0.7	
		2.7 to 3.6			0.8	
V _{OH}	High Level Output Voltage	1.65 to 3.6	I _O =-100 μA	V _{CC} -0.2		V
		1.65	I _O =-4 mA	1.2		
		2.3	I _O =-8 mA	1.7		
		2.7	I _O =-12 mA	2.2		
		3.0	I _O =-12 mA	2.4		
		3.0	I _O =-24 mA	2.2		
V _{OL}	Low Level Output Voltage	1.65 to 3.6	I _O =100 μA		0.2	V
		1.65	I _O =4 mA		0.45	
		2.3	I _O =8 mA		0.7	
		2.7	I _O =12 mA		0.4	
		3.0	I _O =12 mA		0.4	
		3.0	I _O =24 mA		0.55	
I _I	Input Leakage Current	3.6	V _I = V _{CC} or GND		± 5	μA
I _{I(HOLD)}	Input Hold Current	1.65	V _I = 0.58V	25		μA
		1.65	V _I = 1.07V	-25		
		2.3	V _I = 0.7V	45		
		2.3	V _I = 1.7V	-45		
		3	V _I = 0.8V	75		
		3	V _I = 2V	-75		
		3.6	V _I = 0 to 3.6V		± 500	
I _{OZ}	High Impedance Output Leakage Current	3.6	V _O = V _{CC} or GND		± 10	μA
I _{off}	Power Off Leakage Current	0	V _I or V _O = 0 to 3.6V		20	μA
I _{CC}	Quiescent Supply Current	3.6	V _I = V _{CC} or GND, I _O = 0		40	μA
ΔI _{CC}	I _{CC} incr. per Input	3.0 to 3.6	V _{IH} = V _{CC} -0.6V other V _I = V _{CC} or GND		750	μA

74ALVCH32245
AC ELECTRICAL CHARACTERISTICS

Symbol	Parameter	Test Condition			Value		Unit
		V _{CC} (V)	C _L (pF)		-40 to 85 °C		
					Min.	Max.	
t _{PLH} t _{PHL}	Propagation Delay Time	2.3 to 2.7	30		1.0	3.7	ns
		2.7	50		1.0	3.6	
		3.0 to 3.6	50		1.0	3.0	
t _{PZL} t _{PZH}	Output Enable Time	2.3 to 2.7	30		1.0	5.7	ns
		2.7	50		1.0	5.4	
		3.0 to 3.6	50		1.0	4.4	
t _{PLZ} t _{PHZ}	Output Disable Time	2.3 to 2.7	30		1.0	5.2	ns
		2.7	50		1.0	4.6	
		3.0 to 3.6	50		1.0	4.1	

CAPACITIVE CHARACTERISTICS

Symbol	Parameter	Test Condition		Value			Unit
		V _{CC} (V)		T _A = 25 °C			
				Min.	Typ.	Max.	
C _{IN}	Input Capacitance	3.3	V _I = 0V or V _{CC}		4		pF
C _{OUT}	Output Capacitance	3.3	V _I = 0V or V _{CC}		8		pF
C _{PD}	Power Dissipation Capacitance (note 1)	2.5	f _{IN} = 10MHz		22		pF
		3.3	V _I = 0V or V _{CC}		28		

1) C_{PD} is defined as the value of the IC's internal equivalent capacitance which is calculated from the operating current consumption without load. (Refer to Test Circuit). Average operating current can be obtained by the following equation. I_{CC(opr)} = C_{PD} × V_{CC} × f_{IN} + I_{CC}/32 (per circuit)

74ALVCH32245

TEST CIRCUIT

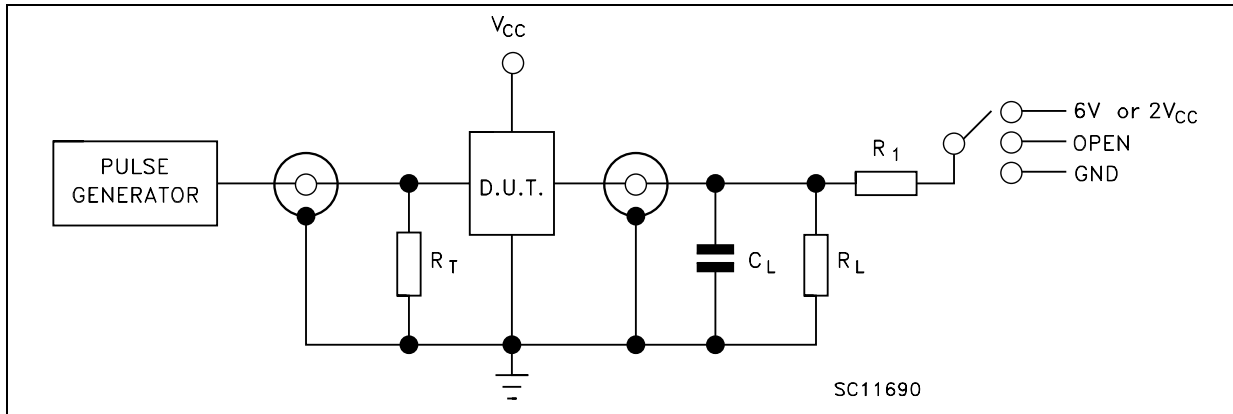

TEST	SWITCH
t_{PLH} , t_{PHL}	Open
t_{PZL} , t_{PLZ} ($V_{CC} = 3.0$ to $3.6V$)	6V
t_{PZL} , t_{PLZ} ($V_{CC} = 2.3$ to $2.7V$)	$2V_{CC}$
t_{PZH} , t_{PHZ}	GND

$R_T = Z_{OUT}$ of pulse generator (typically 50Ω)

TEST CIRCUIT AND WAVEFORM SYMBOL VALUE

Symbol	V_{CC}			
	3.0 to 3.6V	2.7V	2.3 to 2.7V	1.65 to 1.95V
V_{IH}	2.7V	2.7V	V_{CC}	V_{CC}
V_M	1.5V	1.5V	$V_{CC}/2$	$V_{CC}/2$
V_X	$V_{OL} + 0.3V$	$V_{OL} + 0.3V$	$V_{OL} + 0.15V$	$V_{OL} + 0.15V$
V_Y	$V_{OH} - 0.3V$	$V_{OH} - 0.3V$	$V_{OH} - 0.15V$	$V_{OH} - 0.15V$
C_L	50pF	50pF	30pF	30pF
$R_L = R_1$	500 Ω	500 Ω	500 Ω	1000 Ω
$t_r = t_f$	<2.5ns	<2.5ns	<2.0ns	<2.0ns

74ALVCH32245

WAVEFORM 1: PROPAGATION DELAY (f=1MHz; 50% duty cycle)

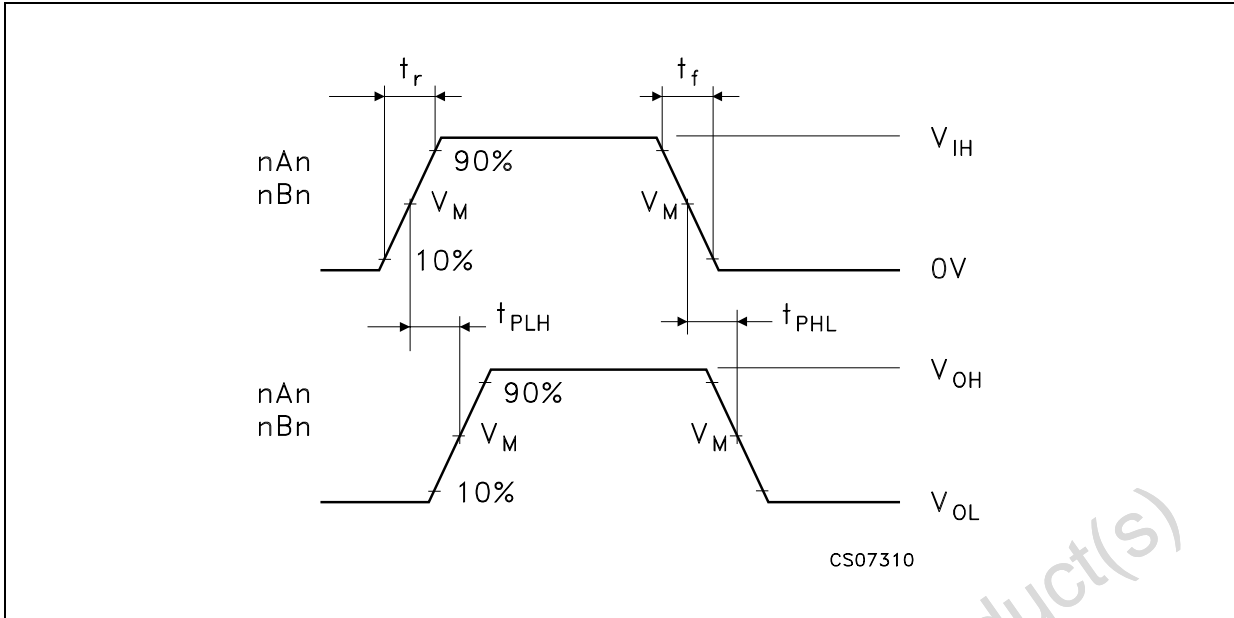

WAVEFORM 2: OUTPUT ENABLE AND DISABLE TIME (f=1MHz; 50% duty cycle)

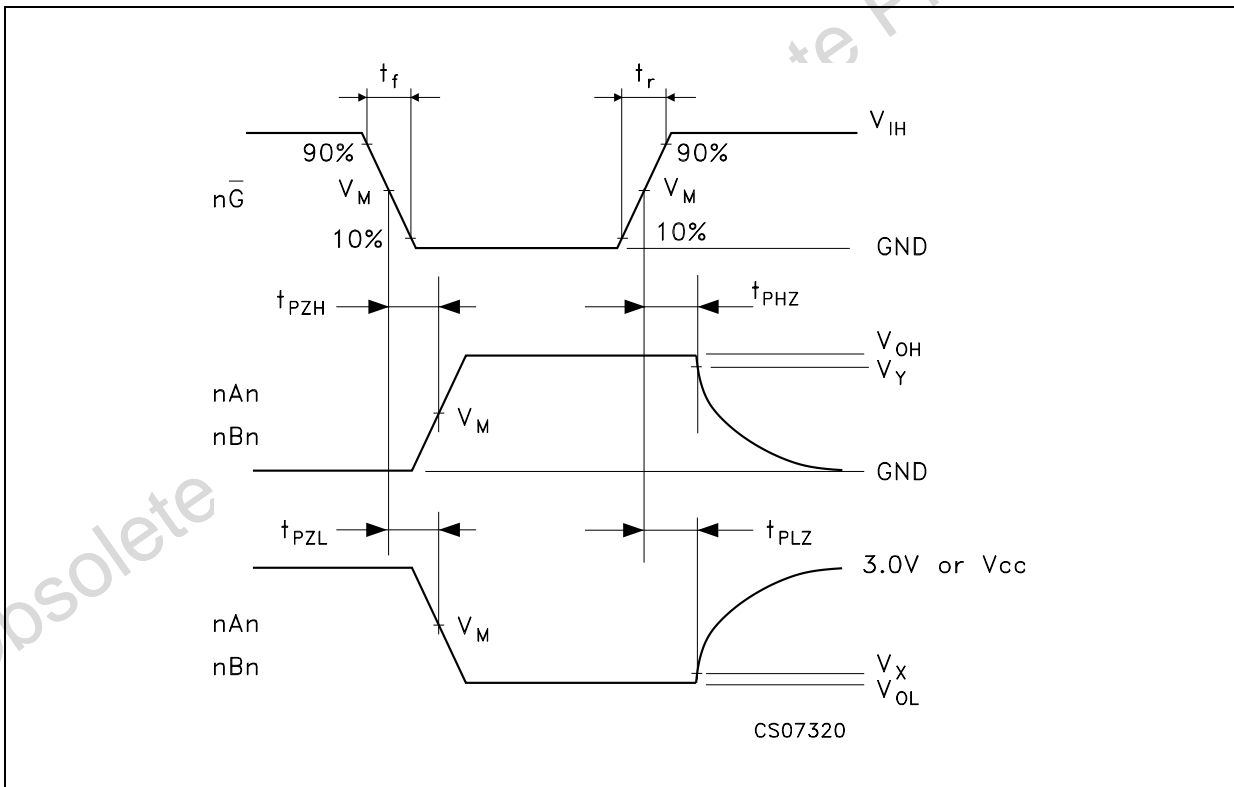

74ALVCH32245

LFBGA96 MECHANICAL DATA

DIM.	mm.			mils		
	MIN.	TYP.	MAX.	MIN.	TYP.	MAX.
A	13.40		13.60	527.5		535.4
B	5.40		5.60	212.6		220.5
C			1.6			63.0
D		0.5			19.7	
E		0.8			31.5	
F	1		.15			45.3

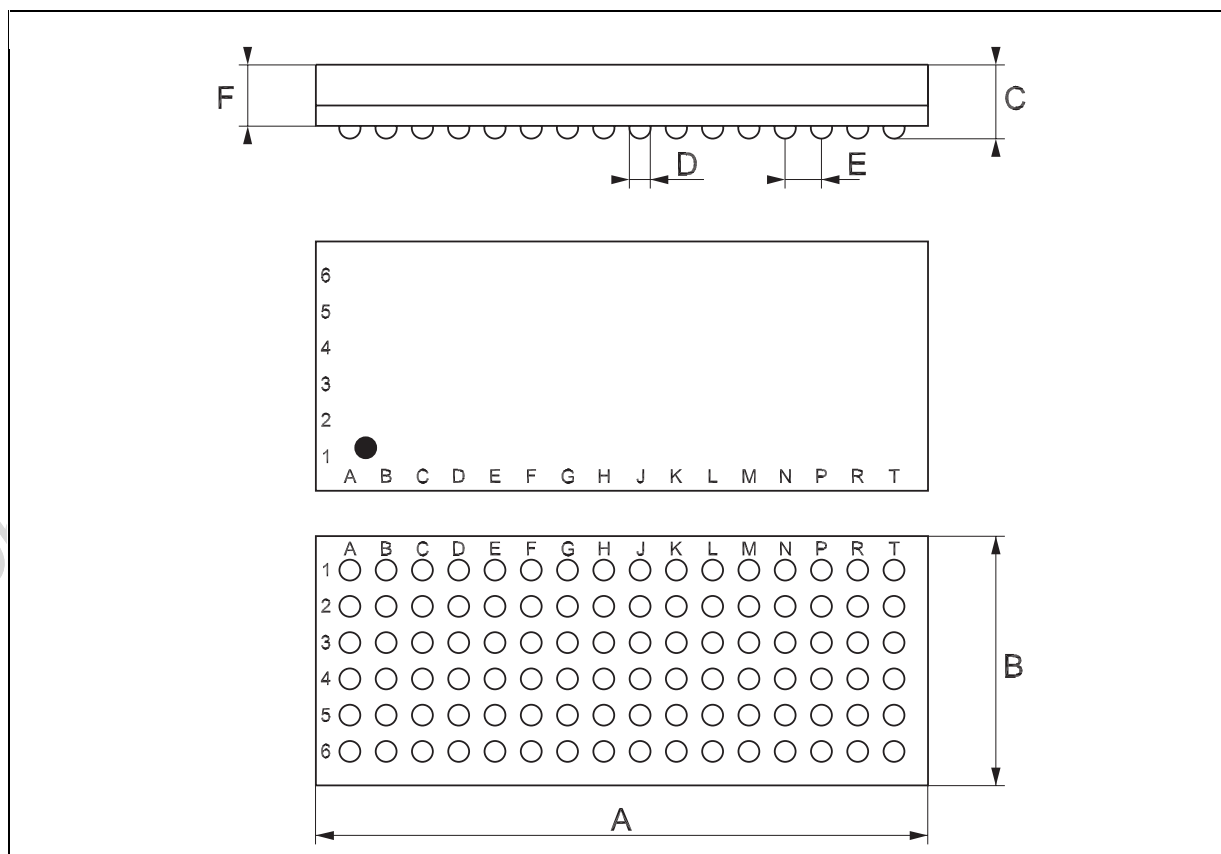

74ALVCH32245

Information furnished is believed to be accurate and reliable. However, STMicroelectronics assumes no responsibility for the consequences of use of such information nor for any infringement of patents or other rights of third parties which may result from its use. No license is granted by implication or otherwise under any patent or patent rights of STMicroelectronics. Specifications mentioned in this publication are subject to change without notice. This publication supersedes and replaces all information previously supplied. STMicroelectronics products are not authorized for use as critical components in life support devices or systems without express written approval of STMicroelectronics.

© The ST logo is a registered trademark of STMicroelectronics

© 2002 STMicroelectronics - Printed in Italy - All Rights Reserved
STMicroelectronics GROUP OF COMPANIES

Australia - Brazil - Canada - China - Finland - France - Germany - Hong Kong - India - Israel - Italy - Japan - Malaysia - Malta - Morocco
Singapore - Spain - Sweden - Switzerland - United Kingdom - United States.

© <http://www.st.com>