

Excellent Integrated System Limited

Stocking Distributor

Click to view price, real time Inventory, Delivery & Lifecycle Information:

[STMicroelectronics](#)
[L9613B013TR](#)

For any questions, you can email us directly:

sales@integrated-circuit.com



L9613

Data interface

Features

- Operating power supply voltage range $4.8V \leq V_S \leq 36V$ (40V for transients)
- Reverse supply (battery) protected down to $V_S \geq -24V$
- Standby mode with very low current consumption $I_{S_{SB}} \leq 1mA$ @ $V_{CC} \leq 0.5V$
- Min. possible Baud rate according to ISO9141 ≥ 130 kBaud
- Low quiescent current in off condition $I_{S_{OFF}} = 120\mu A$
- TTL compatible TX input
- Bidirectional K-I/O pin with supply voltage dependent input threshold
- Over temperature shut down function selective to K-I/O pin
- Wide input and output voltage range: $-24V \leq V_K \leq V_S$
- K output current limitation, typ. $I_K = 60mA$
- Defined OFF output status in under voltage condition and V_S or GND interruption
- Controlled output slope for low EMI

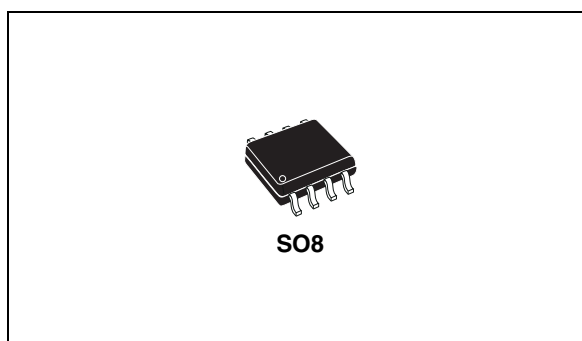

- High input impedance for open V_S or GND connection
- Defined output ON status of LO or RX for open LI or K inputs
- Defined K output OFF for TX input open
- Integrated pull up resistors for TX, RX and LO
- EMI robustness optimized

Description

The L9613 is a monolithic integrated circuit containing standard ISO 9141 compatible interface functions.

Table 1. Device summary

Order code	Package	Packing
L9613B	SO8	Tube
L9613B013TR	SO8	Tape and reel

Contents

1	Block diagram and pin description	3
1.1	Block diagram	3
1.2	Pin description	3
2	Electrical specification	4
2.1	Absolute maximum ratings	4
2.2	Thermal data	4
2.3	Electrical characteristics	4
3	Functional description	7
3.1	ESD application hints	12
4	Package information	13
5	Revision history	14

L9613

Block diagram and pin description

1 Block diagram and pin description

1.1 Block diagram

Figure 1. Block diagram

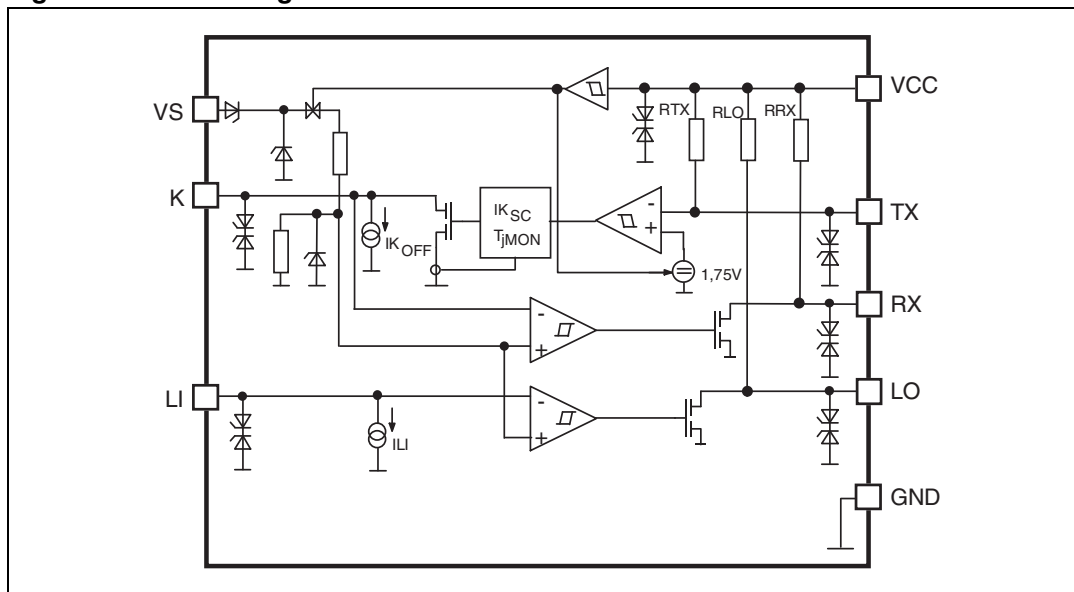

1.2 Pin description

Figure 2. Pin connection (top view)

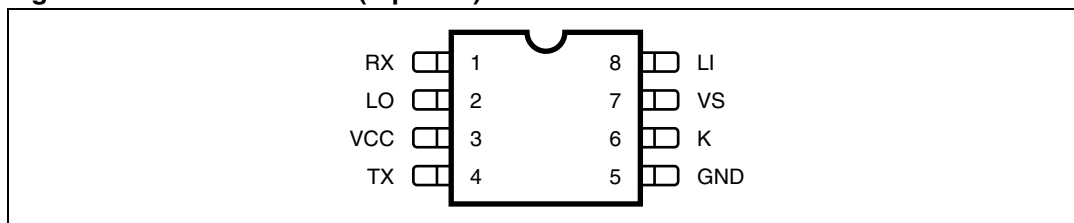

Table 2. Pin description

N.	Name	Function
1	RX	Output for K as input
2	LO	Output L comparator
3	VCC	Stabilized voltage supply
4	TX	Input for K as output
5	GND	Common GND
6	K	Bidirectional I/O
7	VS	Supply voltage
8	LI	Input L comparator

2 Electrical specification

2.1 Absolute maximum ratings

Table 3. Absolute maximum ratings (No damage or latch)

Symbol	Parameter	Value	Unit
V_S	Supply voltage	-24 to +36	V
	ISO transients $t \leq 400$ ms	-24 to +40	
V_{CC}	Stabilized voltage	-24 to +7	V
$\Delta V_S/d_t$	Supply voltage transient	-10 to +10	V/ μ s
$V_{LI, K}$	Pin voltage	-24 to V_S	V
$V_{LO, RX, TX}$		-24 to V_{CC}	V

Note: Max. ESD voltages are $\pm 2kV$ with human body model $C = 100pF$, $R = 1.5k$ corresponds to maximum energy dissipation 0.2mJ according to MIL883C.

2.2 Thermal data

Table 4. Thermal data

Symbol	Parameter	Min.	Typ.	Max.	Unit
T_{JSDon}	Temperature K shutdown switch on threshold	160		200	$^{\circ}C$
T_{JSDoff}	Temperature K shutdown switch off threshold	150		200	$^{\circ}C$
$R_{th j-amb}$	Thermal steady state junction to ambient resistance	130	155	180	$^{\circ}C/W$

2.3 Electrical characteristics

Table 5. Electrical characteristics

(The electrical characteristics are valid within the below defined operating conditions, unless otherwise specified. The function is guaranteed by design until T_{JSDon} temperature shutdown switch-on-threshold. $V_S = 4.8$ to 18V; $V_{CC} = 3$ to 7V; $T_j = -40$ to $+150^{\circ}C$).

Symbol	Parameter	Test condition	Min.	Typ.	Max.	Unit
I_{CC}	Supply V_{CC} current	$V_{CC} \leq 5.5V$; $V_{LI}, V_{TX} = 0V$		1.4	2.3	mA
		$V_K \geq V_{K_{high}}$; $V_{LI} \geq V_{LI_{high}}$ $V_{TX} = V_{CC}$ @ $V_{CC} \leq 5.5V$	-5	40	150	μA
I_{SON}	Supply V_S Current	$V_{LI}, V_{TX} = 0V$ $V_{CC} \leq 0.5V$ @ $V_S \leq 12V$ (1)		3.5 <1	10 50	mA μA
I_{SUB}		$V_{CC} \leq 0.5V$ @ $V_S \leq 16V$			100	μA
$V_{K_{low}}$	Input voltage low state	RX output status LOW	-24		$0.40V_S$	V
$V_{K_{high}}$	Input voltage high state	RX output status HIGH	$0.60V_S$		V_S	V

L9613

Electrical specification

Table 5. Electrical characteristics (continued)

(The electrical characteristics are valid within the below defined operating conditions, unless otherwise specified. The function is guaranteed by design until T_{JSDon} temperature shutdown switch-on-threshold. $V_S = 4.8$ to $18V$; $V_{CC} = 3$ to $7V$; $T_j = -40$ to $+150^\circ C$).

Symbol	Parameter	Test condition	Min.	Typ.	Max.	Unit
VK_{hys}	Input threshold hysteresis	$VK_{high} - VK_{low}$ $V_S \geq 8V$ $V_S \geq 6V$	0.2 0.08	$0.05V_S$	1	V
IK_{off}	Input current	@ $V_{TX} \geq V_{TX_{high}}$ $V_S, V_{CC} \geq 0$ or V_S $V_{CC} = open$ or $GND = open$	-5	4	25	μA
RK_{ON}	Output ON impedance	@ $V_S \geq 6.5V$ $V_{TX} \leq V_{TX_{low}}$ $IK \geq 7mA$ (2)		10	30	Ω
IK_{SC}	Short circuit current	@ $V_S \geq 6.5V$	40	60	150	mA
VK_{sat}	Output saturation voltage	$R_{KO} = 1.5k\Omega$			1	V
$V_{TX_{low}}$	Input voltage LOW state		-24		1	V
$V_{TX_{high}}$	Input voltage HIGH state		3.5		V_{CC}	V
RRX_{ON} RLO_{ON}	Output ON impedance	$VK \leq VK_{low}; VLI \leq VLI_{low}$ $V_S \geq 6.5V$ $I_{RX, LO} \geq 1mA$		40	90	Ω
VRX_{sat} VLO_{sat}	Saturation output voltage	no external load			1	V
IRX_{SC} ILO_{SC}	Output short circuit current	@ $V_S \geq 6.5V$	9	20	50	mA
RTX	Input pull-up resistance	Output status = (HIGH) $T_{amb} = \leq 85^\circ C$ $-0.15V \leq VLO \leq V_{CC} + 0.15V$ $-0.15V \leq VRX \leq V_{CC} + 0.15V$	5	10	18	$k\Omega$
RTX	Input pull up resistance	$-0.15V \leq V_{TX} \leq V_{CC} + 0.15V$ $T_{amb} = \leq 125^\circ C$	10	20	40	$k\Omega$
VLI_{low}	Input voltage LOW state	LO output status LOW	-24		$0.40V_S$	V
$V_{L_{high}}$	Input voltage HIGH state	LO output status HIGH	$0.60V_S$		V_S	V
VLI_{hys}	Input threshold hysteresis	$VLI_{high} - VLI_{low}$		$0.025V_S$	0.8	V
ILI	Input current	$V_S, V_{CC} \geq 0$ or $V_S, V_{CC} = open$ or $GND = open$	-5	4	40	μA
$C_{Ki, LO, RX}$	Internal output capacities				20	pF
f_{LI-LO} f_{K-RX} f_{TX-k}	Transmission frequency	$9V < V_S < 16V$ (external loads) $T_{min} \geq 20 \cdot R_{KO} \cdot C_K - K_{line}$	130			kHz

Electrical specification

L9613

Table 5. Electrical characteristics (continued)

(The electrical characteristics are valid within the below defined operating conditions, unless otherwise specified. The function is guaranteed by design until T_{JSDon} temperature shutdown switch-on-threshold. $V_S = 4.8$ to $18V$; $V_{CC} = 3$ to $7V$; $T_j = -40$ to $+150^\circ C$).

Symbol	Parameter	Test condition	Min.	Typ.	Max.	Unit
t_{rLI-LO} t_{rK-RX} t_{rTX-K}	Rise time	for the definition of t_r , t_f see Figure 6 ⁽³⁾		0.4	2	μs
t_{fLI-LO} t_{fK-RX} t_{fTX-K}	Fall time	$9V < V_S < 16V$ (external loads) $T_{min} \geq 20 \cdot R_{KO} \cdot C_K - K_{line}$		0.4	2	μs
$t_{OFF,LI-LO}$ $t_{OFF,K-RX}$ $t_{OFF,TX-K}$	Switch OFF time	for the definition of t_{on} , t_{OFF} see Figure 6 .		1	13	μs
$t_{ON,LI-LO}$ $t_{ON,K-RX}$ $t_{ON,TX-K}$	Switch ON time	$9V < V_S < 16V$ (external loads) $T_{min} \geq 20 \cdot R_{KO} \cdot C_K - K_{line}$		1	13	μs
$t_{dSB ON}$ $t_{dSB OFF}$	Standby reaction time	$V_{TX} = 0V$, $I_K \geq 7mA$ $V_{LI} = 0V$, $9V < V_S < 16V$ see		10 20	20 40	μs

1. In case of spikes on $V_{CC} \geq 0.5V$ KOUT will be switched On for typical $10\mu s$ which represents the standby t_{dSB} reaction time.
2. For output currents lower than this value a series protection diode can become active. See also [Figure 5](#) and [7](#).
3. Speed limitation related to external capacitance $C_{ext RX, LO}$ and internal impedance $C_{LO, RX}$, R_{LO} , R_{RX} for rise time.

$$t_r = R_{LO, RX} \cdot (C_{LO, RX} + C_{ext RX, LO}) \cdot 1.38.$$

3 Functional description

The L9613 is a monolithic bus driver designed to provide bidirectional serial communication in automotive applications.

The device provides a bidirectional link, called K, to the V_{Bat} related diagnosis bus. It also includes a separate comparator L which is also able to be linked to the V_{Bat} bus. The input TX and output RX of K are related to VCC with her integrated pull up resistances. Also the L comparator output LO has a pull up resistance connected to VCC.

All V_{Bat} bus defined inputs LI and K have supply voltage dependent thresholds together with sufficient hysteresis to suppress line spikes. These pins are protected against over voltages, shorts to GND and VS and can also be driven beyond VS and GND. These features are also given for TX, RX and LI only taking into account the behavior of the internal pull up resistances. The thermal shut down function switches OFF the K output if the chip temperature increases above the thermal shut down threshold. To reactivate K again the chip temperature must decrease below the K switch ON temp. To achieve no fault for VS intervillage conditions the outputs will be switched OFF and stay at high impedance. The device is also protected against reverse battery condition. During lack of VS or GND all pins shows high impedance characteristic. To realize a lack of the VS related bus line LI and K the outputs LO and RX shows defined ON status. Suppressing all 4 classes of "Schaffner" signals (Schaffner 1; 2; 3a,b; 4) all pins can be load with short energy pulses of max. $\pm 0.2\text{mJ}$. All these features together with a high possible baud rate $>130\text{Kbaud}$, controlled output slopes for low EMI, a wide power supply voltage range and a real standby function with zero power consumption $I_{SB\ typ} \leq 1\mu\text{A}$ during system de powering $VCC \leq 0.5\text{V}$ make this device high efficient for automotive bus system.

After wake up of the system from SB condition the first output signal will have an additional delay time $td_{typ} \leq 5\mu\text{s}$.

The typical output voltage behavior for the K, LO, RX outputs as a function of the output current is shown in [Figure 4](#). [Figure 5](#) shows a waveform of the output signal when the low level changes from $R_{ON} \cdot I_{OUT}$ to $I_{OUT} \cdot 2 \cdot R_{ON} + U_{BE}$ state. This variation occurs due to too low output current or after a negative transient forced to the output or to the supply voltage line.

Functional description

L9613

Figure 3. Application circuit

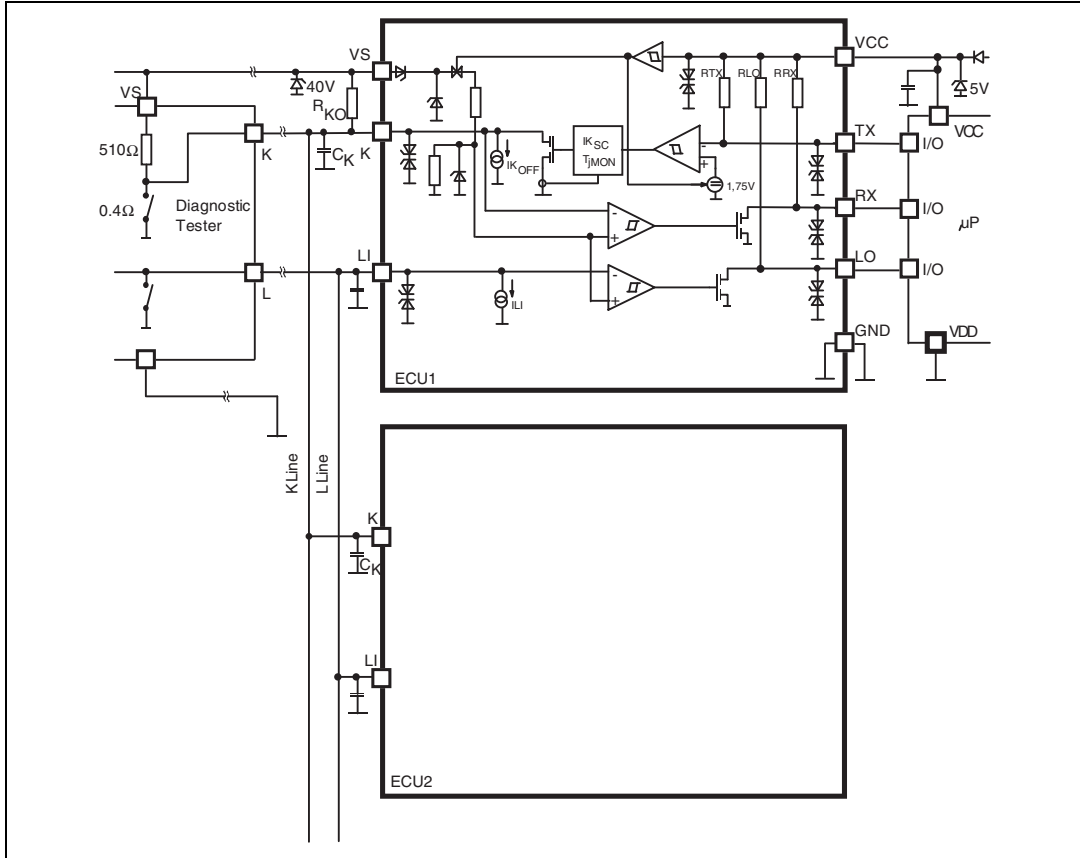
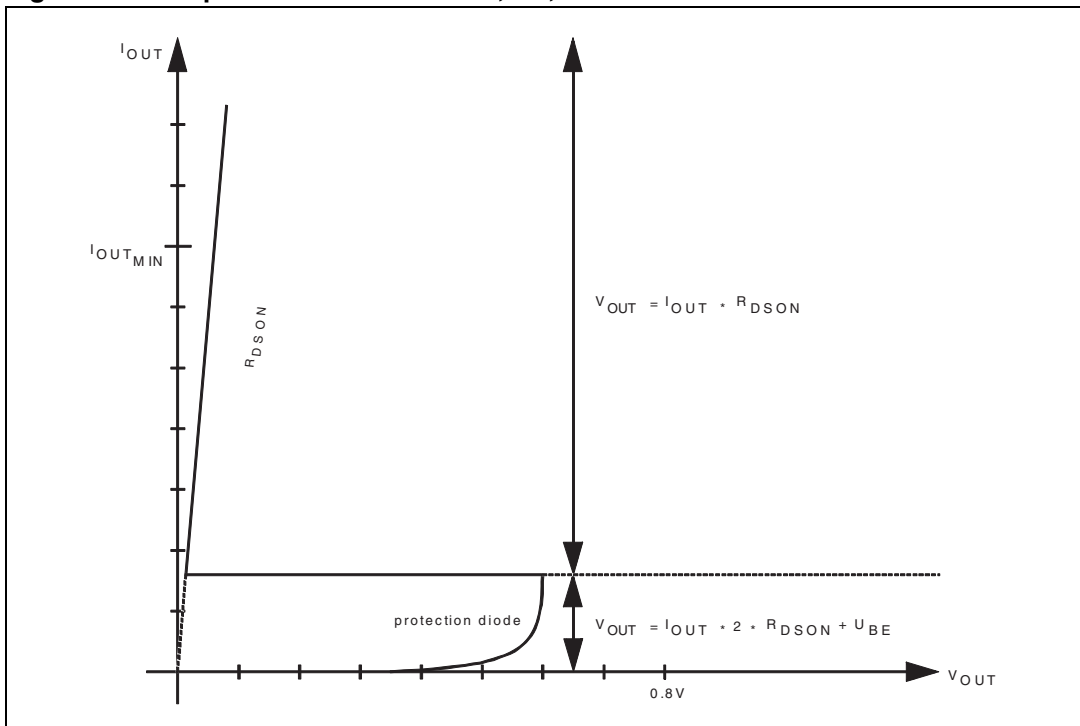

Figure 4. Output characteristics at K, LO, RX



L9613

Functional description

Figure 5. Output signal shape related to output current

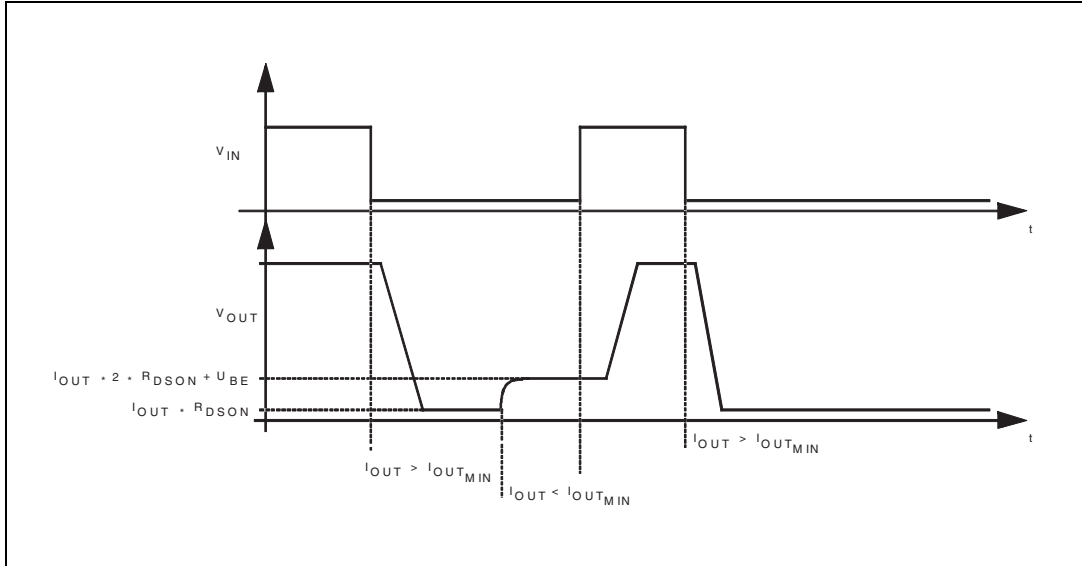
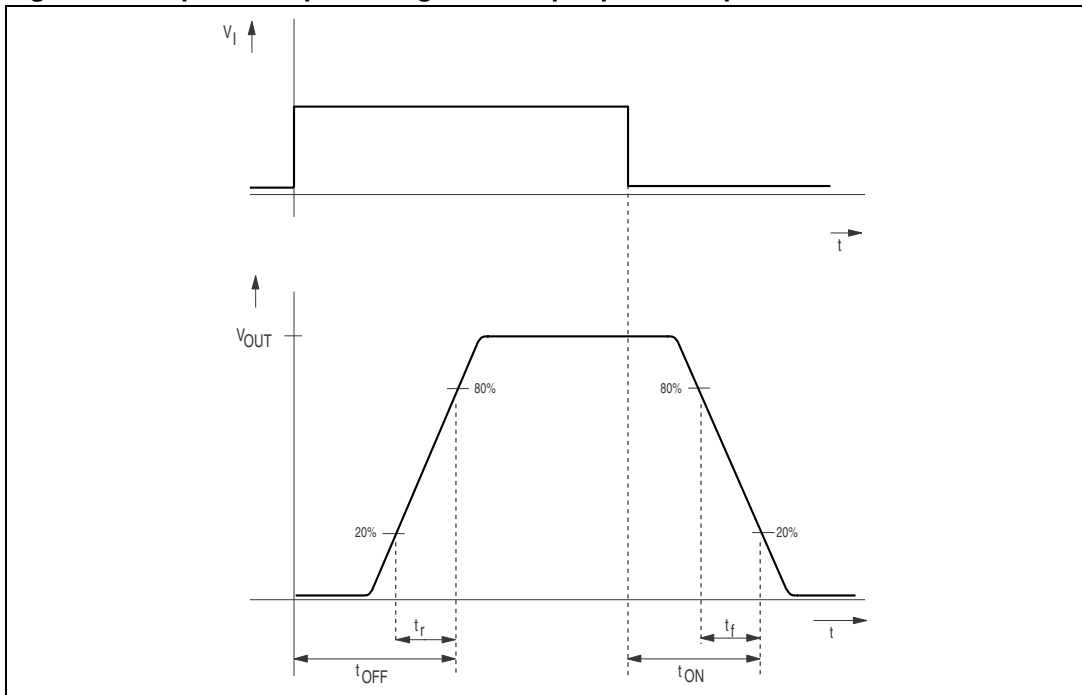

Figure 6. Input to output timings and output pulse shape



Functional description

L9613

Figure 7. Standby reaction time

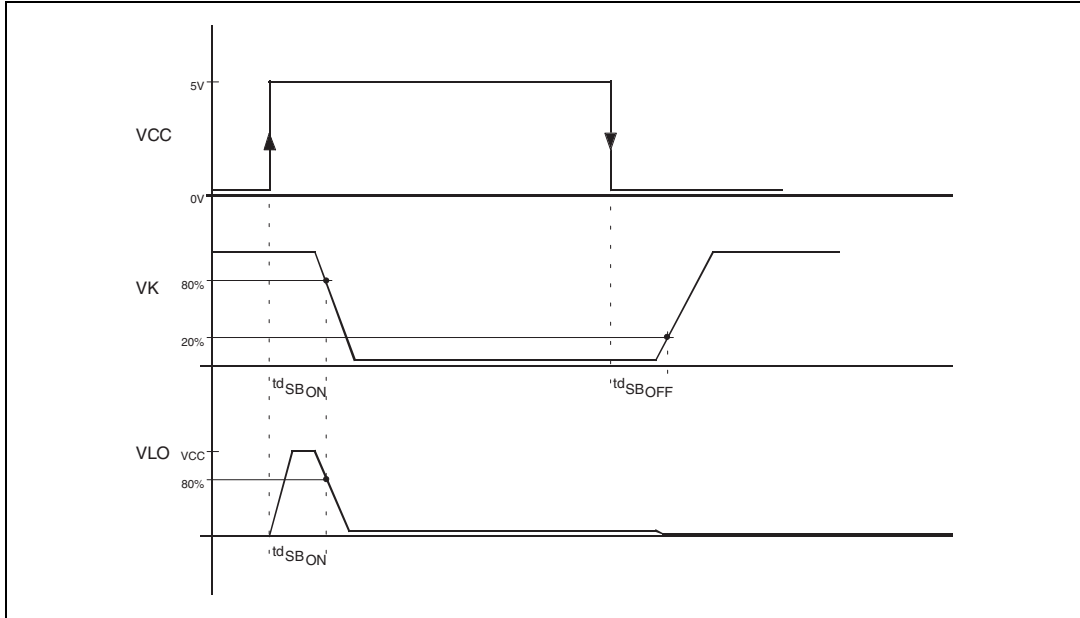
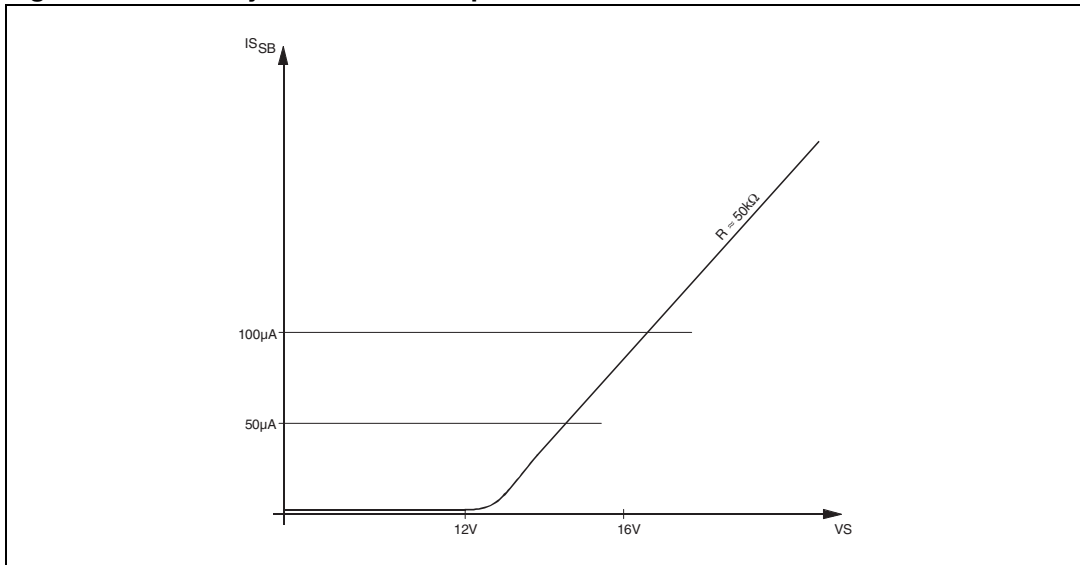

Figure 8. Standby current consumption



L9613

Functional description

Figure 9. EMS performance (ISO 9141 BUS system) diagram

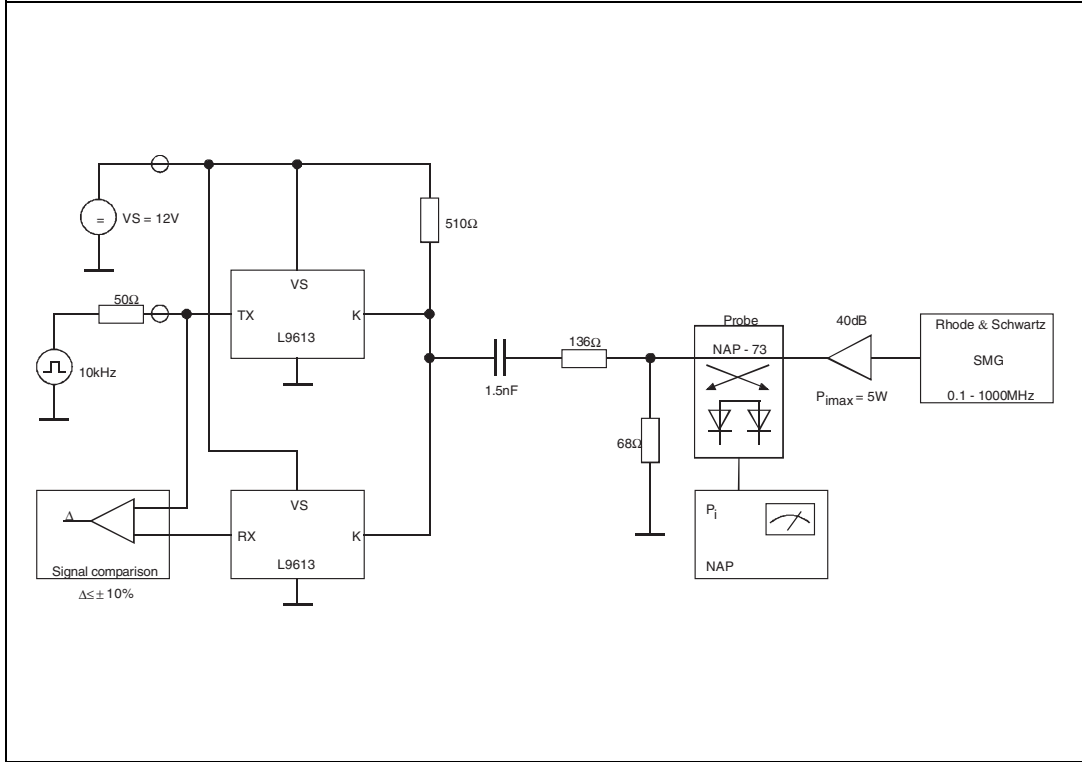
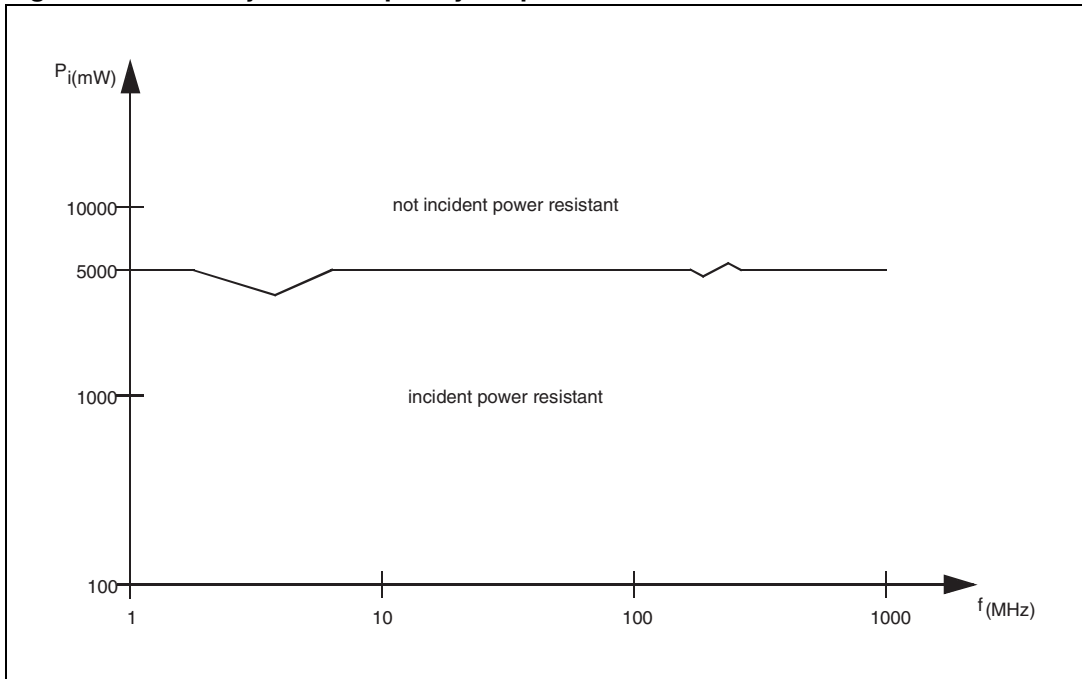

Figure 10. EMS rejection frequency vs. power



Functional description

L9613

3.1 ESD application hints

To improve the ESD robustness of this device above specified ± 2 kV/HBM external blocking capacitors must be used. Nevertheless the max. energy which can be clamped by this device should not exceeds 0.2mJ for each pin. An equivalent input diagram for calculation can be seen in *Figure 11*.

ESD discharge model:

$$E_{ESD} = \frac{1}{2} C_{HBM} U_{ESD}^2 = 0.2mJ + \frac{1}{2} C_{EXT} \cdot (45V)^2$$

Figure 11. Input diagram for calculation

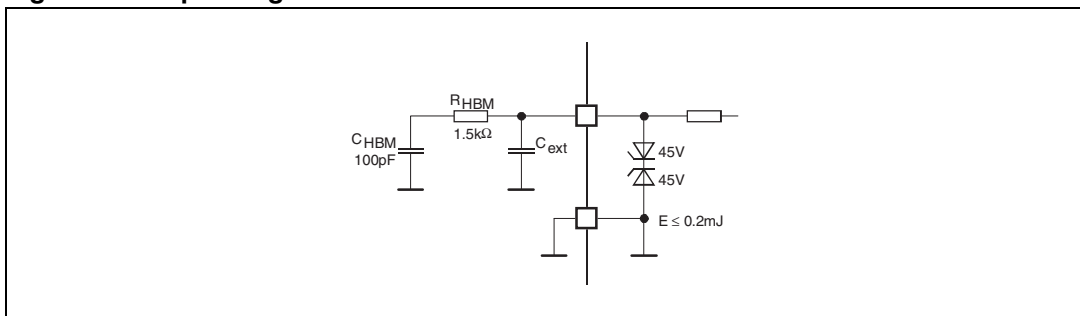

4 Package information

In order to meet environmental requirements, ST (also) offers these devices in ECOPACK[®] packages. ECOPACK[®] packages are lead-free. The category of second Level Interconnect is marked on the package and on the inner box label, in compliance with JEDEC Standard JESD97. The maximum ratings related to soldering conditions are also marked on the inner box label.

ECOPACK is an ST trademark. ECOPACK specifications are available at: www.st.com.

Figure 12. SO8 mechanical data and package dimensions

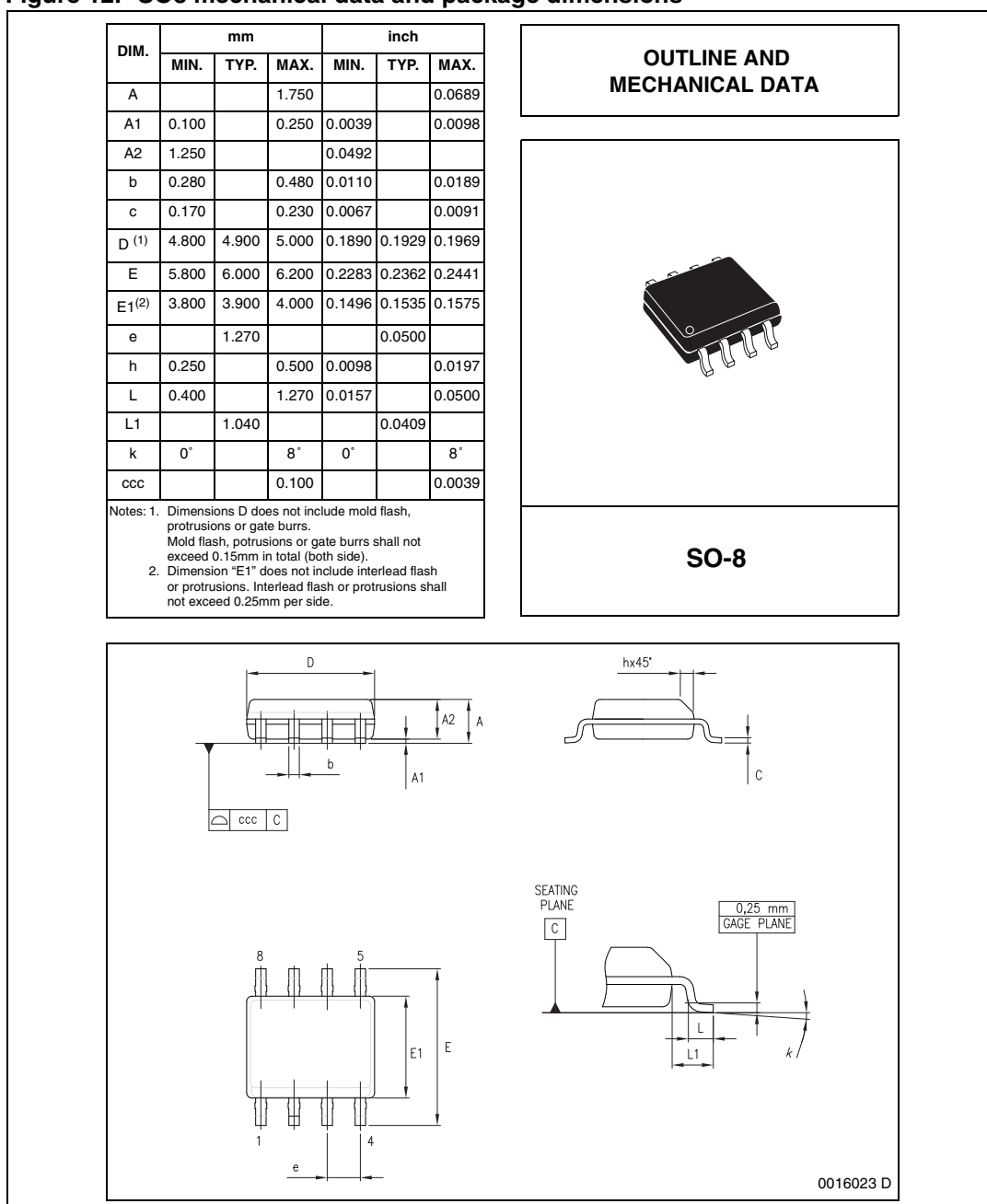

5 Revision history

Table 6. Document revision history

Date	Revision	Changes
24-Jan-2002	1	Initial release.
11-Nov-2008	2	Document reformatted. Added Table 1: Device summary on page 1 . Updated Section 4: Package information on page 13 .
19-Sep-2013	3	Updated Disclaimer.

L9613

Please Read Carefully:

Information in this document is provided solely in connection with ST products. STMicroelectronics NV and its subsidiaries ("ST") reserve the right to make changes, corrections, modifications or improvements, to this document, and the products and services described herein at any time, without notice.

All ST products are sold pursuant to ST's terms and conditions of sale.

Purchasers are solely responsible for the choice, selection and use of the ST products and services described herein, and ST assumes no liability whatsoever relating to the choice, selection or use of the ST products and services described herein.

No license, express or implied, by estoppel or otherwise, to any intellectual property rights is granted under this document. If any part of this document refers to any third party products or services it shall not be deemed a license grant by ST for the use of such third party products or services, or any intellectual property contained therein or considered as a warranty covering the use in any manner whatsoever of such third party products or services or any intellectual property contained therein.

UNLESS OTHERWISE SET FORTH IN ST'S TERMS AND CONDITIONS OF SALE ST DISCLAIMS ANY EXPRESS OR IMPLIED WARRANTY WITH RESPECT TO THE USE AND/OR SALE OF ST PRODUCTS INCLUDING WITHOUT LIMITATION IMPLIED WARRANTIES OF MERCHANTABILITY, FITNESS FOR A PARTICULAR PURPOSE (AND THEIR EQUIVALENTS UNDER THE LAWS OF ANY JURISDICTION), OR INFRINGEMENT OF ANY PATENT, COPYRIGHT OR OTHER INTELLECTUAL PROPERTY RIGHT.

ST PRODUCTS ARE NOT DESIGNED OR AUTHORIZED FOR USE IN: (A) SAFETY CRITICAL APPLICATIONS SUCH AS LIFE SUPPORTING, ACTIVE IMPLANTED DEVICES OR SYSTEMS WITH PRODUCT FUNCTIONAL SAFETY REQUIREMENTS; (B) AERONAUTIC APPLICATIONS; (C) AUTOMOTIVE APPLICATIONS OR ENVIRONMENTS, AND/OR (D) AEROSPACE APPLICATIONS OR ENVIRONMENTS. WHERE ST PRODUCTS ARE NOT DESIGNED FOR SUCH USE, THE PURCHASER SHALL USE PRODUCTS AT PURCHASER'S SOLE RISK, EVEN IF ST HAS BEEN INFORMED IN WRITING OF SUCH USAGE, UNLESS A PRODUCT IS EXPRESSLY DESIGNATED BY ST AS BEING INTENDED FOR "AUTOMOTIVE, AUTOMOTIVE SAFETY OR MEDICAL" INDUSTRY DOMAINS ACCORDING TO ST PRODUCT DESIGN SPECIFICATIONS. PRODUCTS FORMALLY ESCC, QML OR JAN QUALIFIED ARE DEEMED SUITABLE FOR USE IN AEROSPACE BY THE CORRESPONDING GOVERNMENTAL AGENCY.

Resale of ST products with provisions different from the statements and/or technical features set forth in this document shall immediately void any warranty granted by ST for the ST product or service described herein and shall not create or extend in any manner whatsoever, any liability of ST.

ST and the ST logo are trademarks or registered trademarks of ST in various countries.

Information in this document supersedes and replaces all information previously supplied.

The ST logo is a registered trademark of STMicroelectronics. All other names are the property of their respective owners.

© 2013 STMicroelectronics - All rights reserved

STMicroelectronics group of companies

Australia - Belgium - Brazil - Canada - China - Czech Republic - Finland - France - Germany - Hong Kong - India - Israel - Italy - Japan - Malaysia - Malta - Morocco - Philippines - Singapore - Spain - Sweden - Switzerland - United Kingdom - United States of America

www.st.com