

Excellent Integrated System Limited

Stocking Distributor

Click to view price, real time Inventory, Delivery & Lifecycle Information:

[STMicroelectronics](#)
[STPAC02F1](#)

For any questions, you can email us directly:

sales@integrated-circuit.com



STPAC02F1

RF DETECTOR FOR POWER AMPLIFIER CONTROL IPAD™ WITH INTERNAL TEMPERATURE COMPENSATION

MAIN PRODUCT CHARACTERISTICS

- 0.8 to 2.5GHz frequency range
- Detection diode voltage drop compensation
- Temperature compensation
- Fast response time
- Low Power consumption
- Chip Scale device
- Low parasitic impedance

DESCRIPTION

The STPAC02F1 is an integrated RF detector for power control chain. It has been developed to convert the RF signal coming from the external coupler into a DC signal usable by the mobile digital stage. It is based on the use of two similar diodes, one assuming the signal detection while the second one is used to compensate the ambient temperature effect. A biasing stage suppresses the detection diode drop voltage effect. The use of the IPAD technology allows the RF front-end designer to save PCB area and to drastically suppress the parasitic inductances of the package.

Target applications are cellular phones and PDA using GSM, DCS, PCS, AMPS, TDMA, CDMA and 800MHz to 2100.MHz frequency ranges.

BENEFITS

- The use of IPAD technology allows the RF front-end designer to save PCB area and to drastically suppress the parasitic inductances.

FUNCTIONAL DIAGRAM

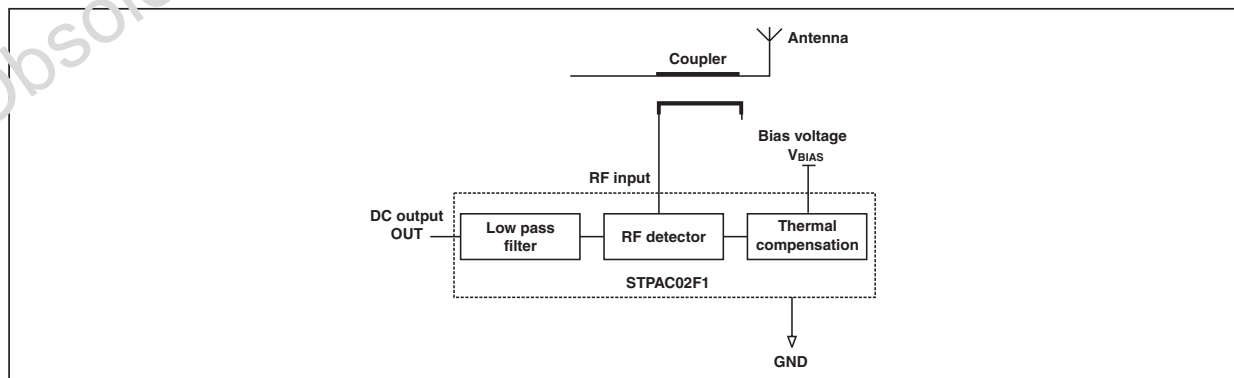

™ : IPAD is a trademark of STMicroelectronics.

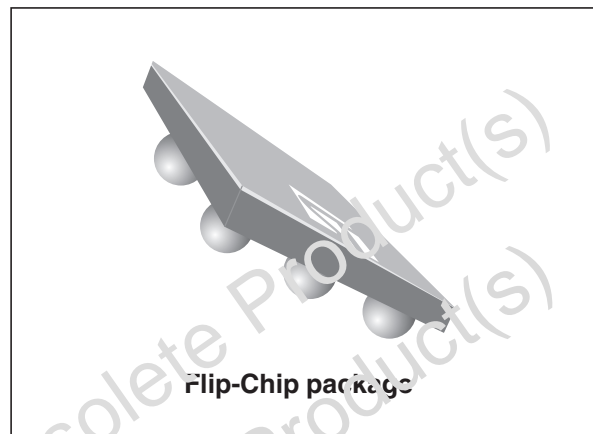

PIN CONFIGURATION (ball side)

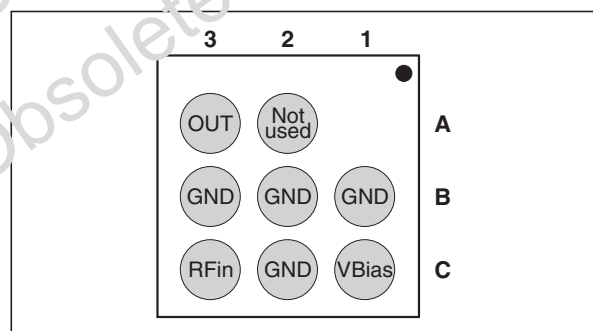

STPAC02F1

ABSOLUTE RATINGS (T_{amb} = 25°C)

Symbol	Parameter and test conditions	Value	Unit
V _{BIAS}	Bias voltage	5	V
P _{RF}	RF power at the RF input	20	dBm
F _{OP}	Operating frequency range	0.8 to 2.5	GHz
V _{PP}	ESD level as per MIL-STD 883E method 3015.7 notice 8 (HBM)	250	V
T _{OP}	Operating temperature range	-30 to +85	°C
T _{STG}	Storage temperature range	-55 to 150	°C

ELECTRICAL CHARACTERISTICS (T_{amb} = 25°C)

PARAMETERS RELATED TO BIAS VOLTAGE

Symbol	Parameter	Test conditions	Min.	Typ.	Max.	Unit
V _{BIAS}	Operating bias voltage		2.3	2.8	3.3	V
I _{BIAS}	Bias current	V _{BIAS} = 3.3 V		1.1	1.6	mA

PARAMETERS RELATED TO DETECTION FUNCTION (V_{BIAS} = 2.8 V, DC output load = 200 kΩ)

Symbol	Parameter	Test conditions	Min.	Typ.	Max.	Unit
V _{DCout}	DC output voltage (see fig. 1)	F = 1.75 GHz, P _{RF} = 10 dBm	0.63	0.69	0.75	V
		F = 1.75 GHz, P _{RF} = -20 dBm	0.20	0.22	0.24	
		F = 0.9 GHz, P _{RF} = 10 dBm	0.69	0.75	0.83	
		F = 0.9 GHz, P _{RF} = -20 dBm	0.20	0.22	0.24	
ΔV _{DCout}	DC output voltage variation (see fig. 1)	2.3V < V _{BIAS} < 3.3V, F = 1.85 GHz, P _{RF} = 10 dBm		100		mV

PARAMETERS RELATED TO RESPONSE TIME (V_{BIAS} = 2.8 V, DC output load = 200 kΩ)

Symbol	Parameter	Test conditions	Min.	Typ.	Max.	Unit
t _{vBIAS}	Delay at V _{BIAS} ON (see fig. 3)	V _{BIAS} from 0 to 3V		1		V
t _{RFon}	Delay at RF ON (see fig. 2)	P _{RF} from 0 to 20dBm		0.2		
t _{RFoff}	Delay at RF OFF (see fig. 2)	P _{RF} from 20 to 0dBm		0.2		

STPAC02F1

Fig. 1: V_{DC} output measurement circuit and temperature compensation measurement.

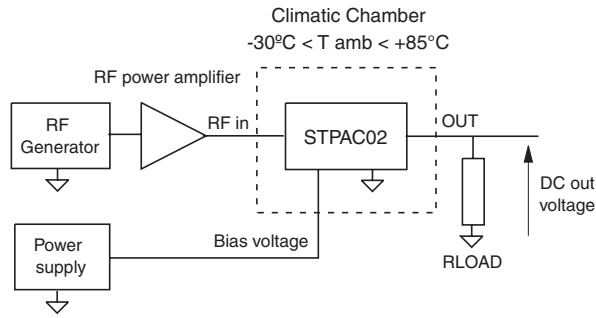

Fig. 2: RF Power ON/OFF response time set-up.

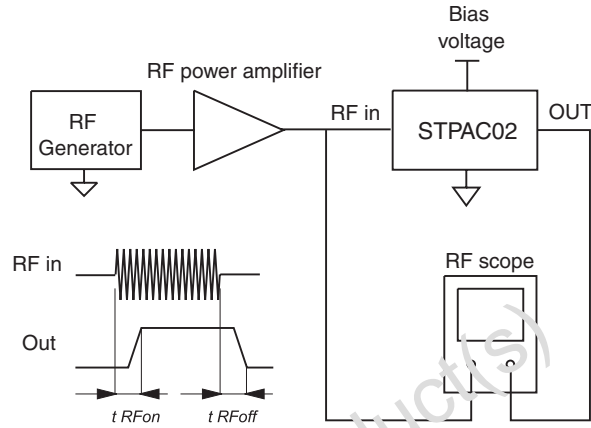

Fig. 3: Power supply turn ON response time.

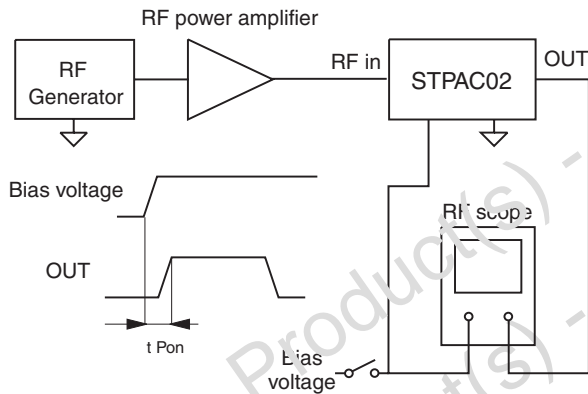

Fig. 4: Temperature sensitivity versus RF Power in (V_{BIAS} = 2.8V, Freq. = 900 MHz).

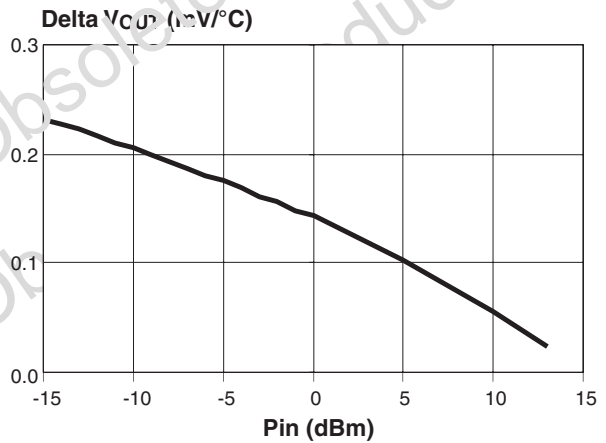

Fig. 5: STPAC02 Output voltage vs. wide RF power range.

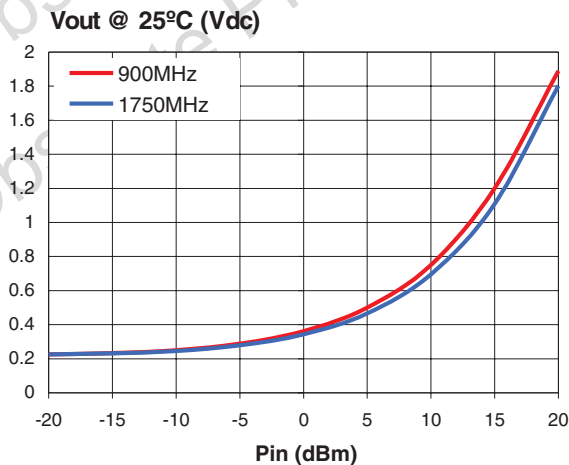
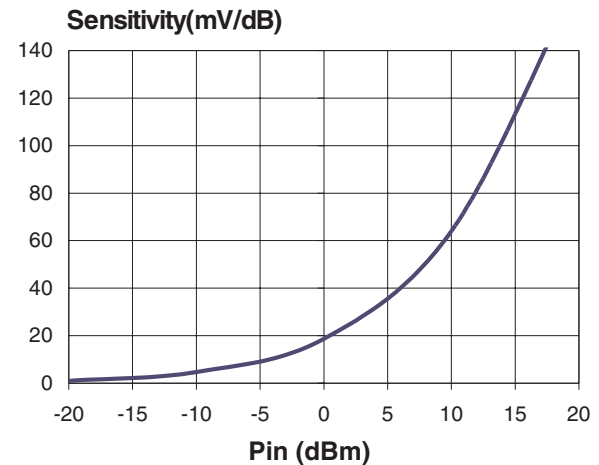

Fig. 6: Power detector sensitivity vs. wide RF power range.



STPAC02F1

Fig. 7: STPAC02 Output voltage at Low RF power.

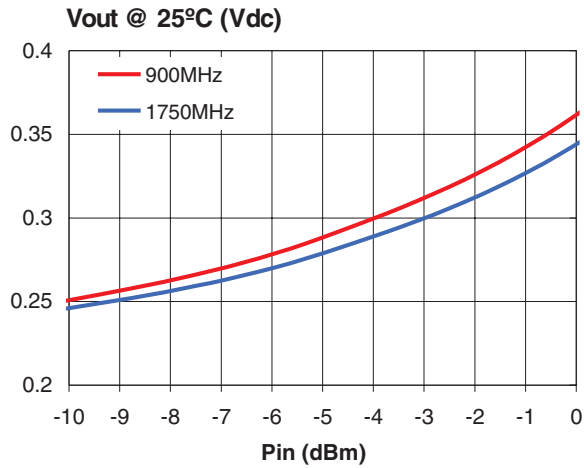
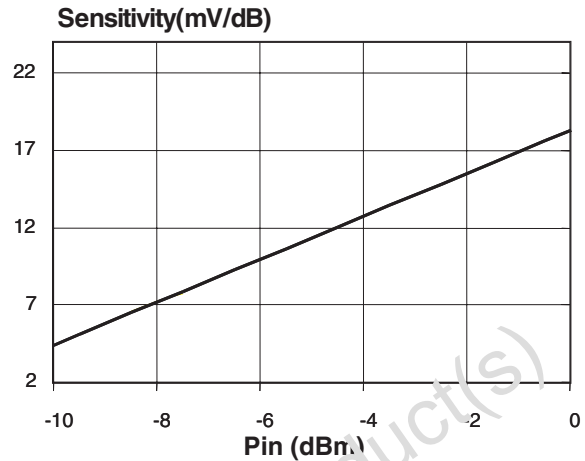
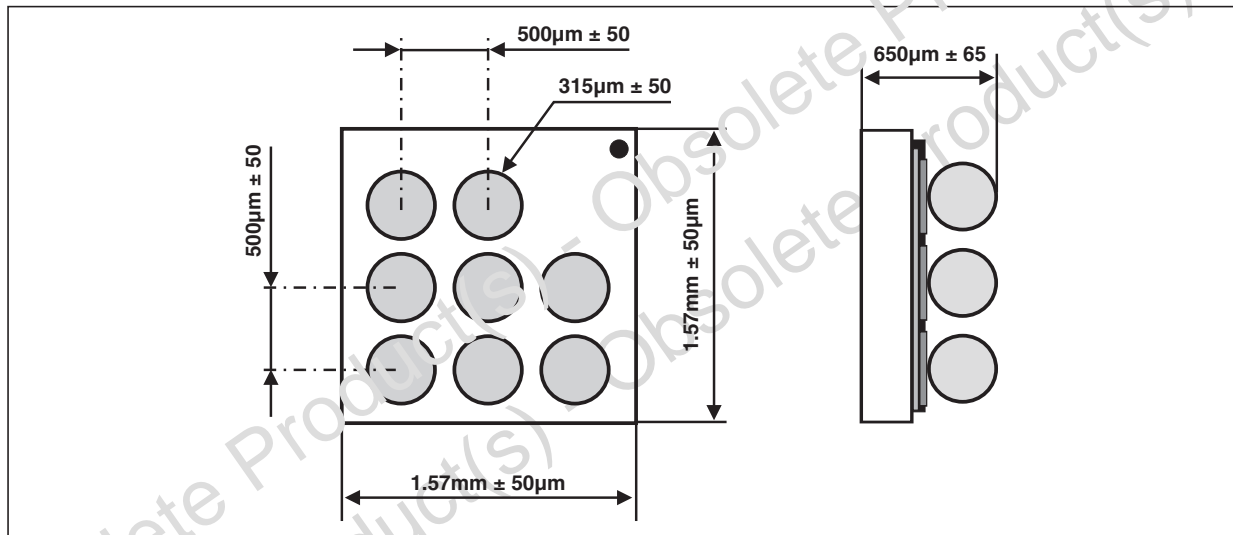

Fig. 8: Power detector sensitivity at low RF power.



PACKAGE MECHANICAL DATA



FOOT PRINT RECOMMENDATIONS

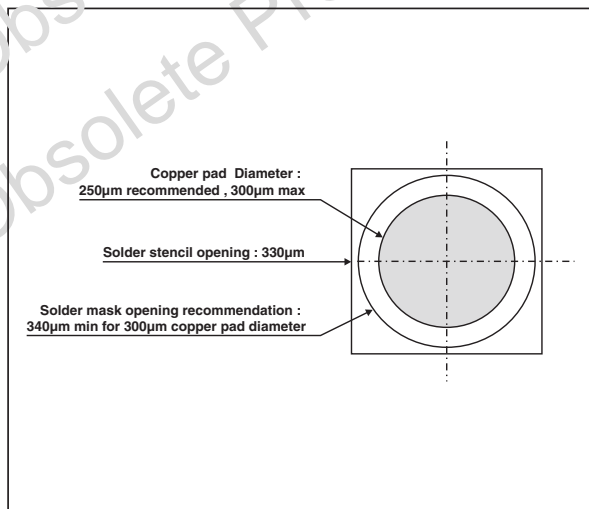

MARKING

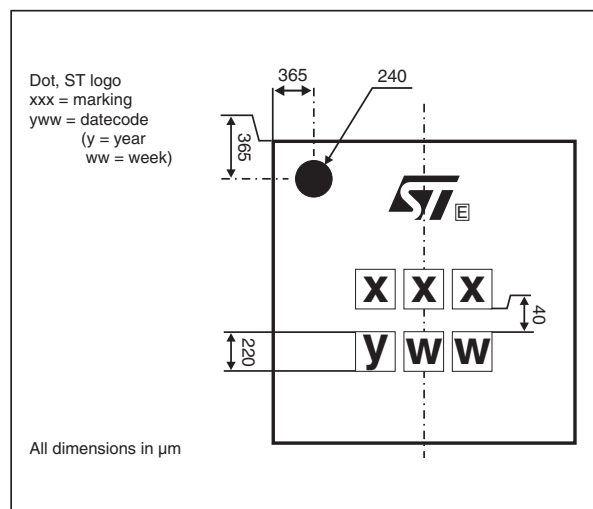

STPAC02F1

FLIP-CHIP TAPE AND REEL SPECIFICATION

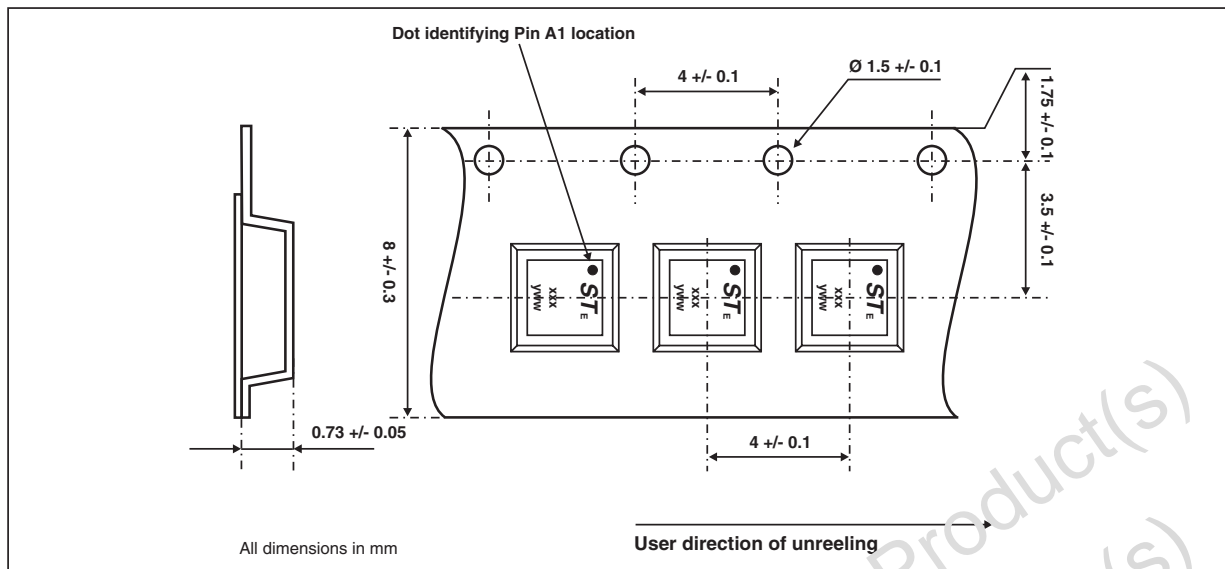

OTHER INFORMATION

Ordering code	Marking	Package	Weight	Base qty	Delivery mode
STPAC02F1	RBT	Flip-Chip	3.3 mg	5000	Tape & reel

Note: More packing informations are available in the application notes:
 AN1235: "Flip-Chip: Package description and recommendations for use"
 AN1751: "EMI Filters: Recommendations and measurements"

Information furnished is believed to be accurate and reliable. However, STMicroelectronics assumes no responsibility for the consequences of use of such information nor for any infringement of patents or other rights of third parties which may result from its use. No license is granted by implication or otherwise under any patent or patent rights of STMicroelectronics. Specifications mentioned in this publication are subject to change without notice. This publication supersedes and replaces all information previously supplied. STMicroelectronics products are not authorized for use as critical components in life support devices or systems without express written approval of STMicroelectronics.

The ST logo is a registered trademark of STMicroelectronics.

All other names are the property of their respective owners.

© 2003 STMicroelectronics - All rights reserved.

STMicroelectronics GROUP OF COMPANIES

Australia - Belgium - Brazil - Canada - China - Czech Republic - Finland - France - Germany - Hong Kong - India - Israel - Italy - Japan - Malaysia - Malta - Morocco - Singapore - Spain - Sweden - Switzerland - United Kingdom - United States

www.st.com