

## Excellent Integrated System Limited

Stocking Distributor

Click to view price, real time Inventory, Delivery & Lifecycle Information:

[STMicroelectronics](#)  
[TSM1012AIST](#)

For any questions, you can email us directly:

[sales@integrated-circuit.com](mailto:sales@integrated-circuit.com)



# TSM1012

## Low consumption voltage and current controller for battery chargers and adapters

Datasheet - production data

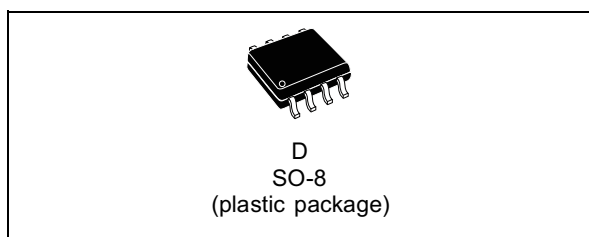

### Features

- Constant voltage and constant current control
- Low consumption
- Low voltage operation
- Low external component count
- Current sink output stage
- Easy compensation
- High ac mains voltage rejection
- **Voltage reference**
  - Fixed output voltage reference 1.25 V
  - 0.5% and 1% voltage precision

### Applications

- Adapters
- Battery chargers

### Description

The TSM1012 is a highly integrated solution for SMPS applications requiring the CV (constant voltage) and CC (constant current) mode.

The TSM1012 device integrates one voltage reference and two operational amplifiers (with ORed outputs - common collectors).

The voltage reference combined with one operational amplifier makes it an ideal voltage controller. The other operational amplifier, combined with few external resistors and the voltage reference, can be used as a current limiter.

**Figure 1. Pin connections (top view)**

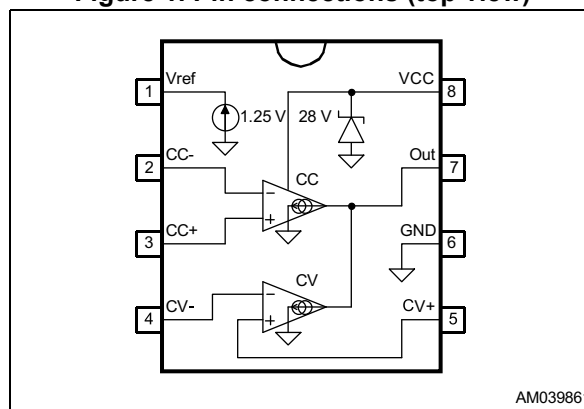

**Table 1. Order codes**

Part number	Temperature range	Package D <sup>(1)</sup>	V <sub>ref</sub> (%)	Marking
TSM1012I	-40 to 105 °C	•	1	M1012
TSM1012AI	-40 to 105 °C	•	0.5	M1012A

1. D = "Small Outline" package (SO) - also available in tape and reel (DT).

## Contents

<b>1</b>	<b>Pin descriptions</b> .....	<b>3</b>
<b>2</b>	<b>Absolute maximum ratings</b> .....	<b>3</b>
<b>3</b>	<b>Operating conditions</b> .....	<b>3</b>
<b>4</b>	<b>Electrical characteristics</b> .....	<b>4</b>
<b>5</b>	<b>Internal schematic</b> .....	<b>6</b>
<b>6</b>	<b>Principle of operation and application hints</b> .....	<b>7</b>
6.1	Voltage and current control .....	7
6.1.1	Voltage control .....	7
6.1.2	Current control .....	7
6.2	Compensation .....	8
6.3	Start-up and short-circuit conditions .....	9
6.4	Voltage clamp .....	9
<b>7</b>	<b>Package information</b> .....	<b>11</b>
7.1	SO-8 package information .....	11
<b>8</b>	<b>Revision history</b> .....	<b>13</b>

## 1 Pin descriptions

Table 2. SO-8 pinout

Name	Pin no.	Type	Function
V <sub>Ref</sub>	1	Analog output	Voltage reference
CC-	2	Analog input	Input pin of the operational amplifier
CC+	3	Analog input	Input pin of the operational amplifier
CV-	4	Analog input	Input pin of the operational amplifier
CV+	5	Analog input	Input pin of the operational amplifier
GND	6	Power supply	Ground line. 0 V reference for all voltages.
OUT	7	Analog output	Output of the two operational amplifiers
VCC	8	Power supply	Power supply line

## 2 Absolute maximum ratings

Table 3. Absolute maximum ratings

Symbol	DC supply voltage	Value	Unit
VCC	DC supply voltage (50 mA =< I <sub>CC</sub> )	-0.3 V to Vz	V
V <sub>i</sub>	Input voltage	-0.3 to VCC	V
T <sub>stg</sub>	Storage temperature	-55 to 150	°C
T <sub>j</sub>	Junction temperature	150	°C
I <sub>ref</sub>	Voltage reference output current	2.5	mA
ESD	Electrostatic discharge	2	kV
R <sub>thja</sub>	Thermal resistance junction to ambient SO-8 package	175	°C/W

## 3 Operating conditions

Table 4. Operating conditions

Symbol	Parameter	Value	Unit
VCC	DC supply conditions	4.5 to Vz	V
T <sub>oper</sub>	Operational temperature	-40 to 105	°C

Electrical characteristics

TSM1012

## 4 Electrical characteristics

$T_{amb} = 25\text{ °C}$  and  $VCC = +18\text{ V}$  (unless otherwise specified).

**Table 5. Electrical characteristics**

Symbol	Parameter	Test condition	Min.	Typ.	Max.	Unit
<b>Total current consumption</b>						
$I_{CC}$	Total supply current, excluding current in voltage reference <sup>(1)</sup> .	$VCC = 18\text{ V}$ , no load $T_{min.} < T_{amb} < T_{max.}$		100	180	$\mu\text{A}$
$V_z$	VCC clamp voltage	$I_{CC} = 50\text{ mA}$		28		V
<b>Operators</b>						
$V_{io}$	Input offset voltage TSM1012  TSM1012A	$T_{amb} = 25\text{ °C}$ $T_{min.} \leq T_{amb} \leq T_{max.}$  $T_{amb} = 25\text{ °C}$ $T_{min.} \leq T_{amb} \leq T_{max.}$		1  0.5	4 5 2 3	mV
$DV_{io}$	Input offset voltage drift			7		$\mu\text{V}/\text{°C}$
$I_{io}$	Input offset current	$T_{amb} = 25\text{ °C}$ $T_{min.} \leq T_{amb} \leq T_{max.}$		2	30 50	nA
$I_{ib}$	Input bias current	$T_{amb} = 25\text{ °C}$ $T_{min.} \leq T_{amb} \leq T_{max.}$		20 50	150 200	nA
SVR	Supply voltage rejection ration	$VCC = 4.5\text{ V to }28\text{ V}$	65	100		dB
$V_{icm}$	Input common mode voltage range		0		$VCC - 1.5$	V
CMR	Common mode rejection ratio	$T_{amb} = 25\text{ °C}$ $T_{min.} \leq T_{amb} \leq T_{max.}$	70 60	85		dB
<b>Output stage</b>						
$G_m$	Transconduction gain. sink current only <sup>(2)</sup>	$T_{amb} = 25\text{ °C}$ $T_{min.} \leq T_{amb} \leq T_{max.}$	0.5	1 1		$\text{mA/mV}$
$V_{ol}$	Low output voltage at 5 mA sinking current	$T_{min.} \leq T_{amb} \leq T_{max.}$		250	400	mV
$I_{os}$	Output short-circuit current. Output to (VCC - 0.6 V). Sink current only.	$T_{amb} = 25\text{ °C}$ $T_{min.} \leq T_{amb} \leq T_{max.}$	6 5	10		mA
<b>Voltage reference</b>						
$V_{ref}$	Reference input voltage TSM1012 1% precision  TSM1012A 0.5% precision	$T_{amb} = 25\text{ °C}$ $T_{min.} \leq T_{amb} \leq T_{max.}$  $T_{amb} = 25\text{ °C}$ $T_{min.} \leq T_{amb} \leq T_{max.}$	1.238 1.225 1.244 1.237	1.25 1.25	1.262 1.273 1.256 1.261	V
$\Delta V_{ref}$	Reference input voltage deviation over the temperature range	$T_{min.} \leq T_{amb} \leq T_{max.}$		20	30	mV

**TSM1012**

**Electrical characteristics**

**Table 5. Electrical characteristics (continued)**

Symbol	Parameter	Test condition	Min.	Typ.	Max.	Unit
RegLine	Reference input voltage deviation over the VCC range.	Iload = 1 mA			20	mV
RegLoad	Reference input voltage deviation over the output current.	VCC = 18 V, 0 < Iload < 2.5 mA			10	mV

1. Test conditions: pin 2 and 6 connected to GND, pin 4 and 5 connected to 1.25 V, pin 3 connected to 200 mV.
2. The current depends on the difference voltage between the negative and the positive inputs of the amplifier. If the voltage on the minus input is 1 mV higher than the positive amplifier, the sinking current at the output OUT will be increased by  $G_m \times 1 \text{ mA}$ .

## 5 Internal schematics

**Figure 2. Internal schematic**

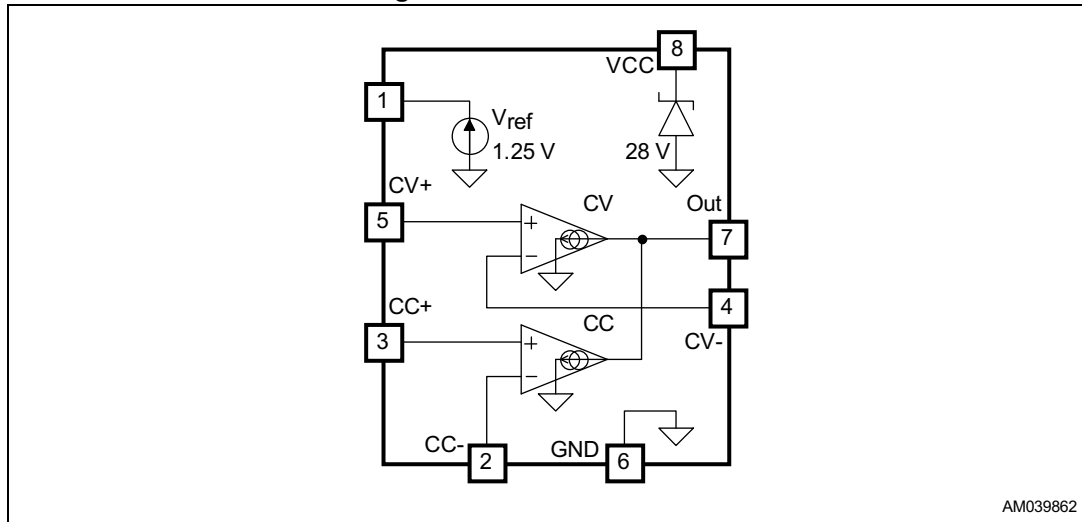

AM039862

**Figure 3. Typical adapter or battery charger application using TSM1012**

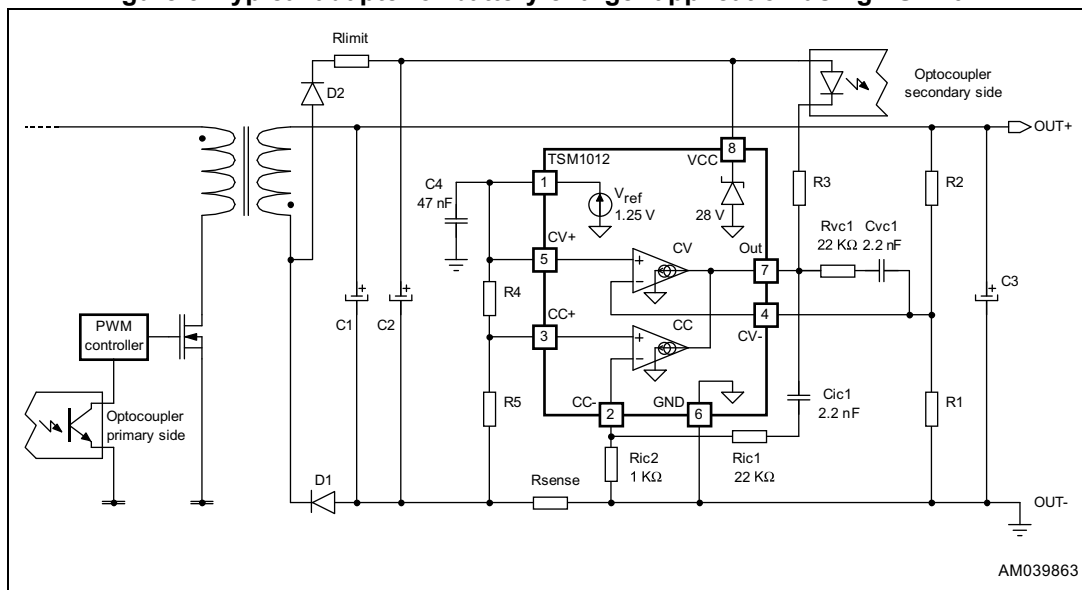

AM039863

In the application schematic shown in [Figure 3](#), the TSM1012 device is used on the secondary side of a flyback adapter (or battery charger) to provide accurate control of the voltage and current. The above feedback loop is made with an optocoupler.

## 6 Principle of operation and application hints

### 6.1 Voltage and current control

#### 6.1.1 Voltage control

The voltage loop is controlled via a first transconductance operational amplifier, the resistor bridge R<sub>1</sub>, R<sub>2</sub>, and the optocoupler which is directly connected to the output.

The relation between the values of the R<sub>1</sub> and R<sub>2</sub> should be chosen as written in [Equation 1](#).

##### Equation 1

$$R_1 = R_2 \times V_{ref} / (V_{out} - V_{ref})$$

Where V<sub>out</sub> is the desired output voltage.

To avoid the discharge of the load, the resistor bridge R<sub>1</sub>, R<sub>2</sub> should be highly resistive. For this type of application, a total value of 100 KΩ (or more) would be appropriate for the resistors R<sub>1</sub> and R<sub>2</sub>.

As an example, with R<sub>2</sub> = 100 KΩ, V<sub>out</sub> = 4.10 V, V<sub>ref</sub> = 1.210 V, then R<sub>1</sub> = 41.9 KΩ.

*Note: If the low drop diode should be inserted between the load and the voltage regulation resistor bridge to avoid current flowing from the load through the resistor bridge, this drop should be taken into account in [Equation 1](#) by replacing V<sub>out</sub> by (V<sub>out</sub> + V<sub>drop</sub>).*

#### 6.1.2 Current control

The current loop is controlled via the second transconductance operational amplifier, the sense resistor R<sub>sense</sub>, and the optocoupler.

The V<sub>sense</sub> threshold is achieved externally by a resistor bridge tied to the V<sub>ref</sub> voltage reference. Its middle point is tied to the positive input of the current control operational amplifier, and its foot is to be connected to the lower potential point of the sense resistor as shown in [Figure 4](#). The resistors of this bridge are matched to provide the best precision possible.

The control equation verifies:

##### Equation 2

$$R_{sense} \times I_{lim} = V_{sense}$$

$$V_{sense} = R_5 \times V_{ref} / (R_4 + R_5)$$

##### Equation 3

$$I_{lim} = R_5 \times V_{ref} / (R_4 + R_5) \times R_{sense}$$

where I<sub>lim</sub> is the desired limited current, and V<sub>sense</sub> is the threshold voltage for the current control loop.

Note that the R<sub>sense</sub> resistor should be chosen taking into account the maximum dissipation (P<sub>lim</sub>) through it during the full load operation.



**Equation 4**

$$P_{lim} = V_{sense} \times I_{lim}$$

Therefore, for most adapter and battery charger applications, a quarter-watt, or half-watt resistor to make the current sensing function is sufficient.

The current sinking outputs of the two transconductance operational amplifiers are common (to the output of the IC). This makes an ORing function which ensures that whenever the current or the voltage reaches too high values, the optocoupler is activated.

The relation between the controlled current and the controlled output voltage can be described with a square characteristic as shown in the following V/I output-power graph.

**Figure 4. Output voltage versus output current**

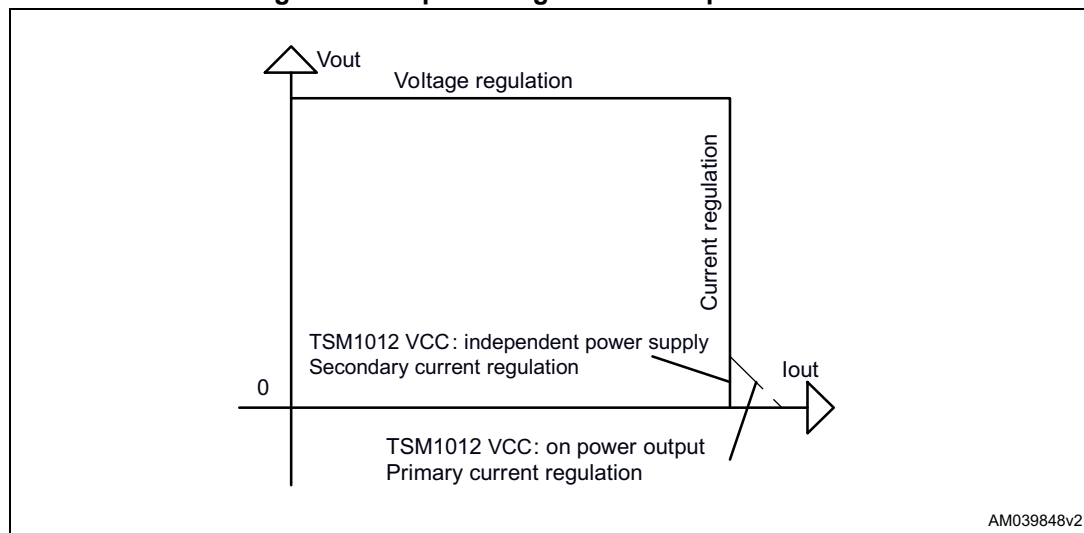

**6.2 Compensation**

The voltage control transconductance operational amplifier can be fully compensated. Both of its output and negative input are directly accessible for external compensation components.

An example of a suitable compensation network is shown in [Figure 6](#). It consists of a capacitor  $C_{vc1} = 2.2 \text{ nF}$  and a resistor  $R_{cv1} = 22 \text{ K}\Omega$  in series.

The current control trans conductance operational amplifier can be fully compensated. Both of its output and negative input are directly accessible for external compensation components.

An example of a suitable compensation network is shown in [Figure 6](#). It consists of a capacitor  $C_{ic1} = 2.2 \text{ nF}$  and a resistor  $R_{ic1} = 22 \text{ K}\Omega$  in series.

### 6.3 Start-up and short-circuit conditions

Under start-up or short-circuit conditions the TSM1012 device is not provided with a high enough supply voltage. This is due to the fact that the chip has its power supply line in common with the power supply line of the system.

Therefore, the current limitation can only be ensured by the primary PWM module, which should be chosen accordingly.

If the primary current limitation is considered not to be precise enough for the application, then a sufficient supply for the TSM1012 device has to be ensured under any condition. It would then be necessary to add some circuitry to supply the chip with a separate power line. This can be achieved in numerous ways, including an additional winding on the transformer.

### 6.4 Voltage clamp

Figure 6 shows how to realize a low-cost power supply for the TSM1012 device (with no additional windings). Please pay attention to the fact that in the particular case presented here, this low-cost power supply can reach voltages as high as twice the voltage of the regulated line. Since the absolute maximum rating of the TSM1012 supply voltage is 28 V. In the aim to protect the TSM1012 device against such high voltage values an internal Zener clamp is integrated.

#### Equation 5

$$R_{limit} = (VCC - V_z) \times I_{Vz}$$

Figure 5. Clamp voltage

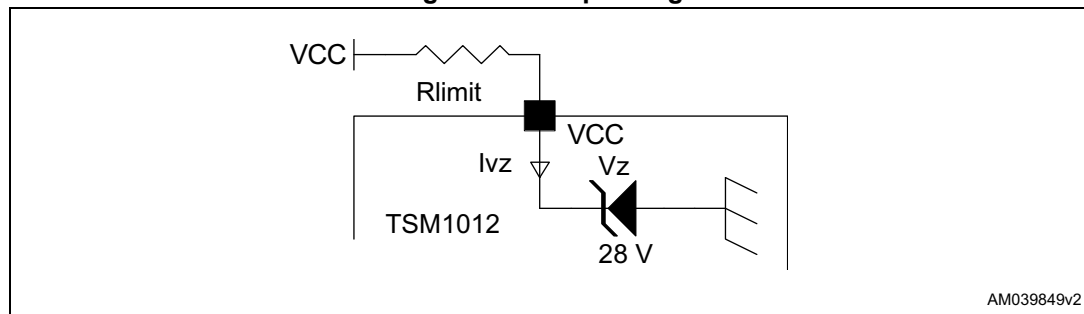

AM039849v2

**Principle of operation and application hints**

**TSM1012**

**Figure 6. Typical application schematic**

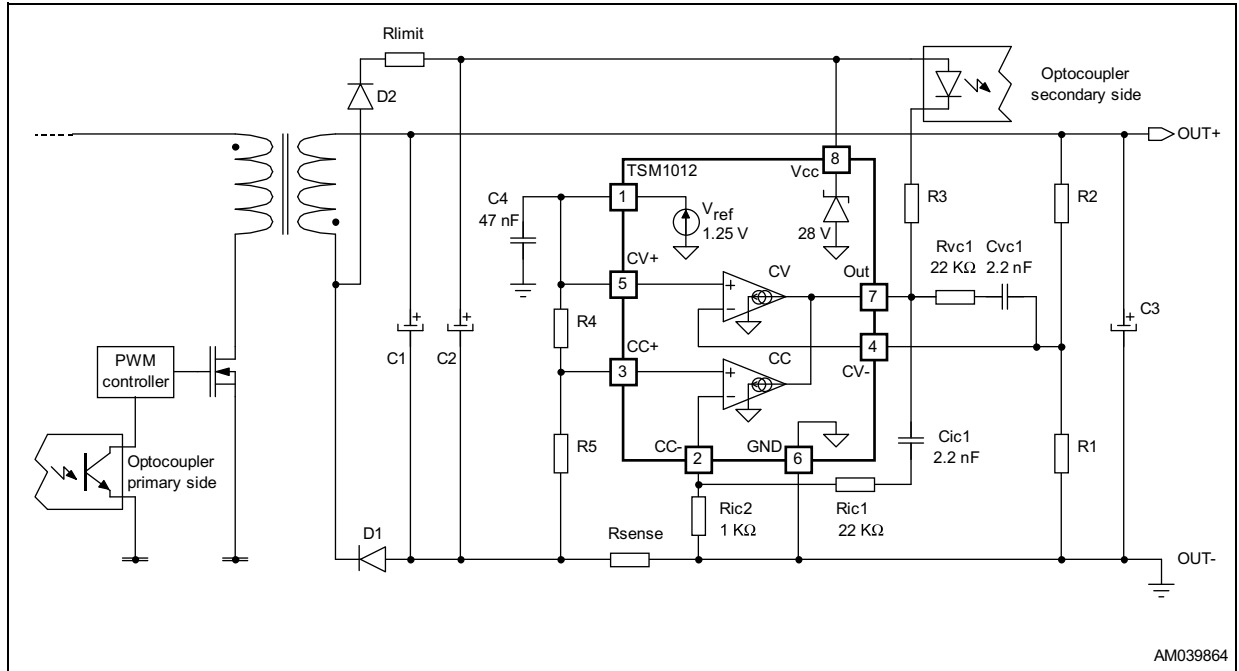

## 7 Package information

In order to meet environmental requirements, ST offers these devices in different grades of ECOPACK® packages, depending on their level of environmental compliance. ECOPACK specifications, grade definitions and product status are available at: [www.st.com](http://www.st.com). ECOPACK is an ST trademark.

### 7.1 SO-8 package information

Figure 7. SO-8 package outline

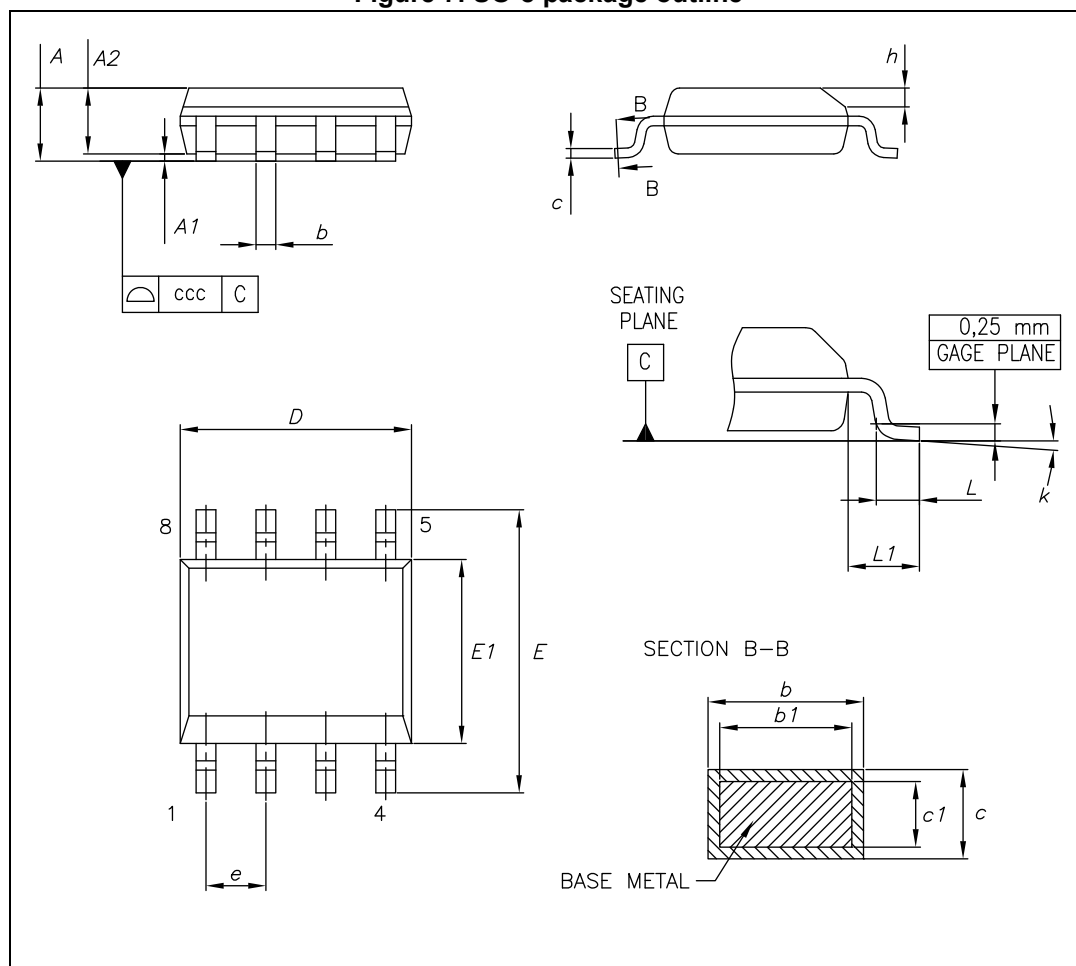

Package information

TSM1012

Table 6. SO-8 package mechanical data

Symbol	Dimensions (mm)		
	Min.	Typ.	Max.
A			1.75
A1	0.10		0.25
A2	1.25		
b	0.28		0.48
c	0.17		0.23
D <sup>(1)</sup>	4.80	4.90	5.00
E	5.80	6.00	6.20
E1 <sup>(2)</sup>	3.80	3.90	4.00
e		1.27	
h	0.25		0.50
L	0.40		1.27
L1		1.04	
k	0°		8°
ccc			0.10

1. Dimension "D" does not include mold flash, protrusions or gate burrs. Mold flash, protrusions or gate burrs shall not exceed 0.15 mm in total (both sides).
2. Dimension "E1" does not include interlead flash or protrusions. Interlead flash or protrusions shall not exceed 0.25 mm per side.

## 8 Revision history

**Table 7. Document revision history**

Date	Revision	Changes
01-Feb-2004	1	Initial release.
15-Apr-2016	2	Removed Mini SO-8 package from the whole document. Updated <a href="#">Section 7: Package information on page 11</a> (replaced <a href="#">Figure 7 on page 11</a> by new figure, updated <a href="#">Table 6 on page 12</a> ). Minor modifications throughout document.

**IMPORTANT NOTICE – PLEASE READ CAREFULLY**

STMicroelectronics NV and its subsidiaries (“ST”) reserve the right to make changes, corrections, enhancements, modifications, and improvements to ST products and/or to this document at any time without notice. Purchasers should obtain the latest relevant information on ST products before placing orders. ST products are sold pursuant to ST’s terms and conditions of sale in place at the time of order acknowledgement.

Purchasers are solely responsible for the choice, selection, and use of ST products and ST assumes no liability for application assistance or the design of Purchasers’ products.

No license, express or implied, to any intellectual property right is granted by ST herein.

Resale of ST products with provisions different from the information set forth herein shall void any warranty granted by ST for such product.

ST and the ST logo are trademarks of ST. All other product or service names are the property of their respective owners.

Information in this document supersedes and replaces information previously supplied in any prior versions of this document.

© 2016 STMicroelectronics – All rights reserved