

Excellent Integrated System Limited

Stocking Distributor

Click to view price, real time Inventory, Delivery & Lifecycle Information:

[Pomona Electronics](#)
[4957](#)

For any questions, you can email us directly:

sales@integrated-circuit.com

Pomona[®]

**Model 4957 & Assembly Instructions
 BNC, Male, Twinax Plug Connector
 To Cable**

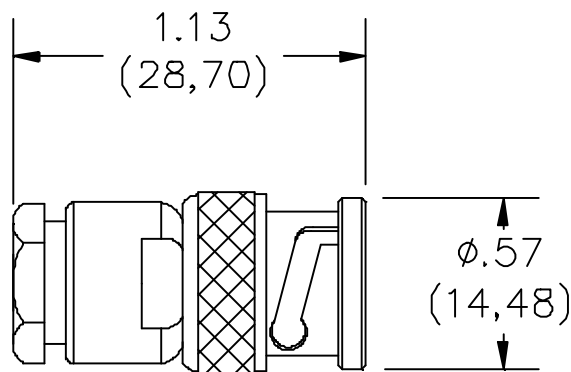

FEATURES:

- Accepts cable types RG108/U, RG108A/U and Belden 9272.
- Polarized Contact (One Male, One Female)

MATERIALS:

Body and Fittings – Brass

Outer Contact - Brass

Male Contact - Brass per QQ-B-626,. Alloy 360, ½ Hard

Female Contact – Beryllium Copper

Dielectric – PTFE

Finish:

Body and Fittings – Tarnish resistant

Center contacts – Gold plated

Outer Contact – Tarnish resistant

Marking: “POMONA 4957”

RATINGS:

Operating Temperature: -65°C (-85°F) to +165°C (+329°F)

Operating Voltage: 500 VRMS Max.

ORDERING INFORMATION: Model 4957

All dimensions are in inches and metric. All specifications are to the latest revisions. Specifications are subject to change without notice. Registered trademarks are the property of their respective companies. Made in USA

Pomona[®]

**Model 4957 & Assembly Instructions
BNC, Male, Twinax Plug Connector
To Cable**

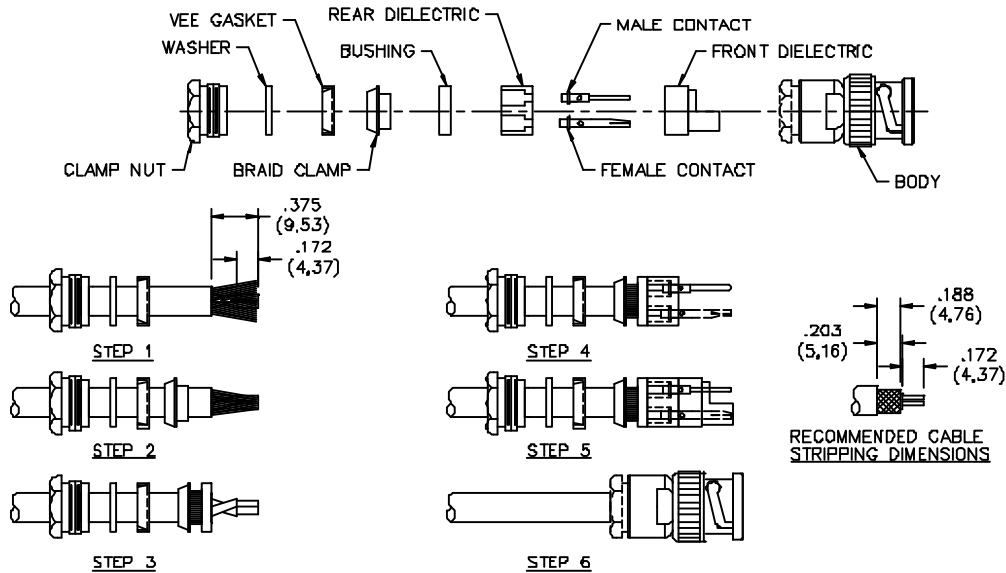

STEP #1

Cut end of cable sharp and square. Slide clamp nut, washer and clamp gasket over jacket. Strip jacket to dimension shown. Comb out braid and fold out. Bare conductors to dimension shown.

STEP #2

Pull braid forward and taper toward conductors. Slide braid clamp over braid as shown and push against cable jacket.

STEP #3

Fold back braid, trip to proper length so no braid strands extend beyond shoulder of braid clamp and evenly form over braid clamp as shown. Slide on bushing. Tin center conductors using minimum amount of heat.

STEP #4

Bend connectors out as necessary for alignment and slide on rear insulator. Solder contacts. Remove any excess solder from contact O.D.

STEP #5

Slide front insulator over contacts and butt against contact shoulders as shown.

STEP #6

Insert prepared cable termination into connector body. Make sure sharp edge of braid clamp seats properly in V-groove clamp gasket. Tighten securely, turning nut only. Do not twist connector body.

All dimensions are in inches and metric. All specifications are to the latest revisions. Specifications are subject to change without notice. Registered trademarks are the property of their respective companies. Made in USA

Sales: 800-490-2361 Fax: 888-403-3360
Technical Assistance: 800-241-2060

PomonaACCESS 90107 (800) 444-6785 or (425) 446-6010
More drawings available at www.pomonaelectronics.com