

## Excellent Integrated System Limited

Stocking Distributor

Click to view price, real time Inventory, Delivery & Lifecycle Information:

[Pomona Electronics](#)  
[5018-0](#)

For any questions, you can email us directly:

[sales@integrated-circuit.com](mailto:sales@integrated-circuit.com)

Pomona®

**Model 5018  
Hex Head Binding Post**

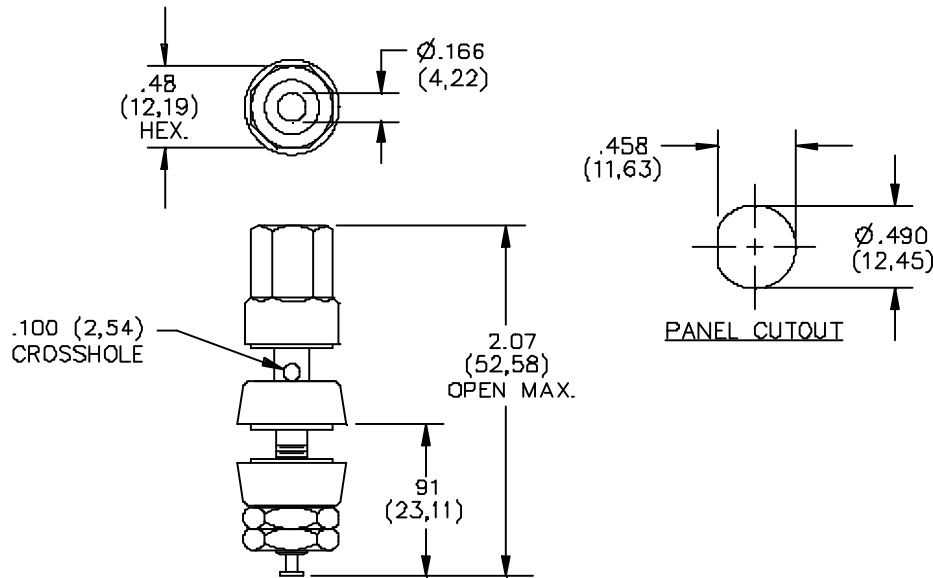

**FEATURES:**

- Meets requirements of MIL-P-55149/1A.

**MATERIALS:**

Binding Post Body, Nuts, Lockwasher: Gold Plated Brass

Insulation: Nylon MIL-P-20693

Flat Washer: Brass

Insulator: Nylon

Hex Nut: Steel

**RATINGS:**

Voltage: Hand-held testing: 30VAC/60VDC Max.

Hands free testing in controlled voltage environments: 1500 VRMS

Operating Temperature: +80°C (+176°F) Max.

Current: 30 Amperes

**ORDERING INFORMATION:** Model 5018-\*

\*=Color, -0 Black, -2 Red, -4 Yellow, -5 Green, -6 Blue, -9 White

Ordering Example: 5018-2 Color is Red

All dimensions are in inches. Tolerances (except noted): .xx = ±.02" (.51 mm), .xxx = ±.005" (.127 mm).

All specifications are to the latest revisions. Specifications are subject to change without notice.

Registered trademarks are the property of their respective companies. Made in USA

# Pomona<sup>®</sup>

<b>Model 5018 Hex Head Binding Post</b>
---

---

All dimensions are in inches. Tolerances (except noted): .xx = ±.02" (.51 mm), .xxx = ±.005" (.127 mm).

All specifications are to the latest revisions. Specifications are subject to change without notice.

Registered trademarks are the property of their respective companies. Made in USA