

Excellent Integrated System Limited

Stocking Distributor

Click to view price, real time Inventory, Delivery & Lifecycle Information:

[Pomona Electronics](#)
[5076-0](#)

For any questions, you can email us directly:

sales@integrated-circuit.com

Pomona®

Model 5076
Strain Relief Boot With Clamp Nut

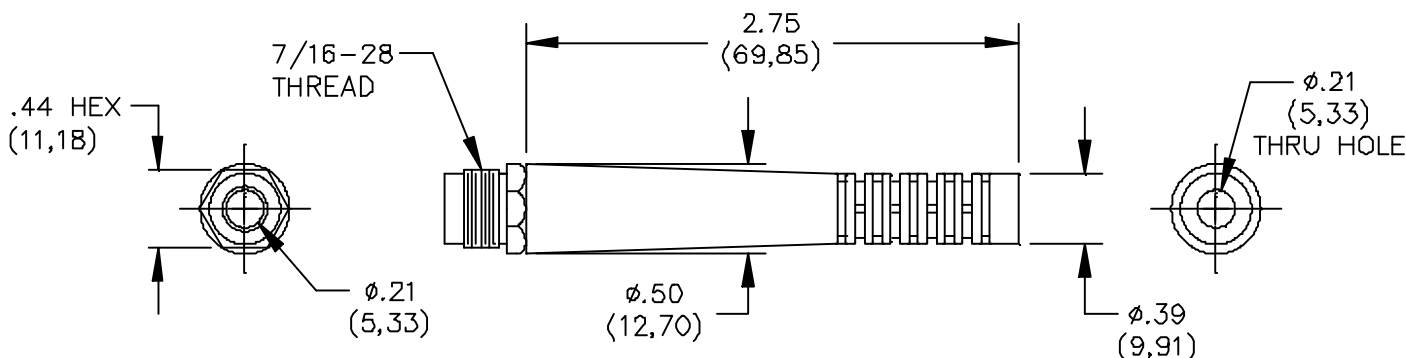

FEATURES:

- Use with RG58 and RG141 cable.
- Use with connectors having 7/16 - 28 clamp nut threads.

MATERIALS:

Clamp Nut: Brass Per QQ-B-626, Alloy 360, 1/2 Hard
 Boot: PVC, Color: See ordering information
 Finish: Clamp Nut: Brass, Nickel Plate Per QQ-N-290, .0002" Min.

RATINGS:

Operating Temperature: +50°C.(+122°F.) Max.
 Operating Voltage: 500 VRMS

ORDERING INFORMATION: Model 5076 -*

*= Color, -0 Black, -2 Red

Ordering Example: 5076-2, Color is Red

Additional Colors can be quoted upon request.

All dimensions are in inches. Tolerances (except noted): .xx = ±.02" (.51 mm), .xxx = ± .005" (.127 mm).
 All specifications are to the latest revisions. Specifications are subject to change without notice.
 Registered trademarks are the property of their respective companies. Made in USA