



Distributor of Pomona Electronics: Excellent Integrated System Limited

Datasheet of 5419-12-0 - CORD MINIPINER PATCH 12" BLACK

Contact us: [sales@integrated-circuit.com](mailto:sales@integrated-circuit.com) Website: [www.integrated-circuit.com](http://www.integrated-circuit.com)

---

## Excellent Integrated System Limited

Stocking Distributor

Click to view price, real time Inventory, Delivery & Lifecycle Information:

[Pomona Electronics](#)  
[5419-12-0](#)

For any questions, you can email us directly:

[sales@integrated-circuit.com](mailto:sales@integrated-circuit.com)

Pomona®

**Model 5419**  
**Minipincer® Test Clips Each End**

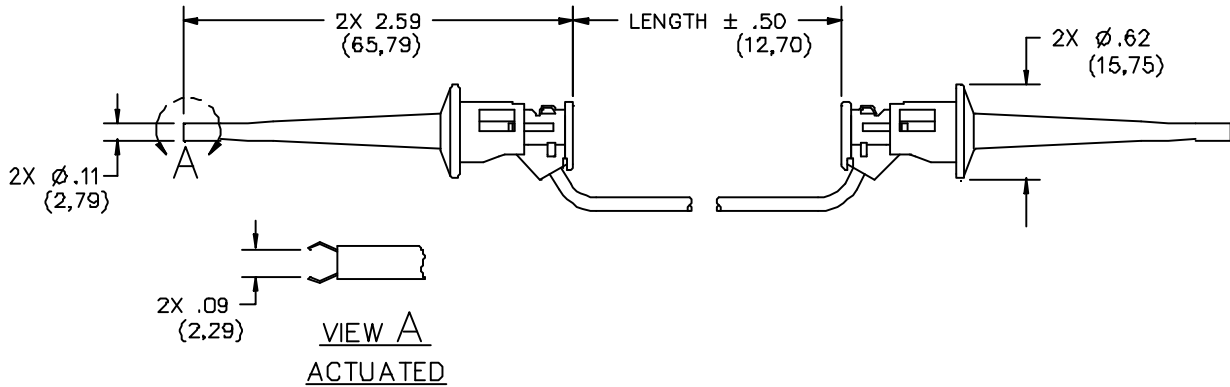

**FEATURES:**

- Ideal for providing jumper wires between small components.

**MATERIALS:**

Conn: 1<sup>st</sup> End - Minipincer® Test Clip  
 Material: Beryllium copper contact.  
 Finish: Gold plated.  
 Insulation: Nylon  
 Wire: 20 AWG, 41 x 36 t.c. PVC insulated, 2.2 (.087) O.D.  
 Marking: "POMONA 5419-XX-\*"   
 Conn: 2<sup>nd</sup> End – Same as first

**RATINGS:**

Operating Temperature: +80°C. (+176°F.) Max.  
 Voltage: Hand-held testing: 30VAC/60VDC Max.  
 Hands free testing in controlled voltage environments: 300 WVDC Max.  
 Current: 5 Amperes Max.

**ORDERING INFORMATION:** Model 5419-XX-\*

XX – Cable Lengths, Standard Lengths: 8" (203), 12" (305), 18" (457), 24" (610), 36" (914), 48" (1219) & 60" (1524).

\*= Color, -0 Black, -2 Red

Ordering Example: 5419-60-2 Indicates 60" in length, color is Red

All dimensions are in inches. Tolerances (except noted): .xx = ±.02" (.51 mm), .xxx = ± .005" (.127 mm).  
 All specifications are to the latest revisions. Specifications are subject to change without notice.  
 Registered trademarks are the property of their respective companies. Made in USA