

Excellent Integrated System Limited

Stocking Distributor

Click to view price, real time Inventory, Delivery & Lifecycle Information:

[Pomona Electronics](#)
[5689A](#)

For any questions, you can email us directly:

sales@integrated-circuit.com

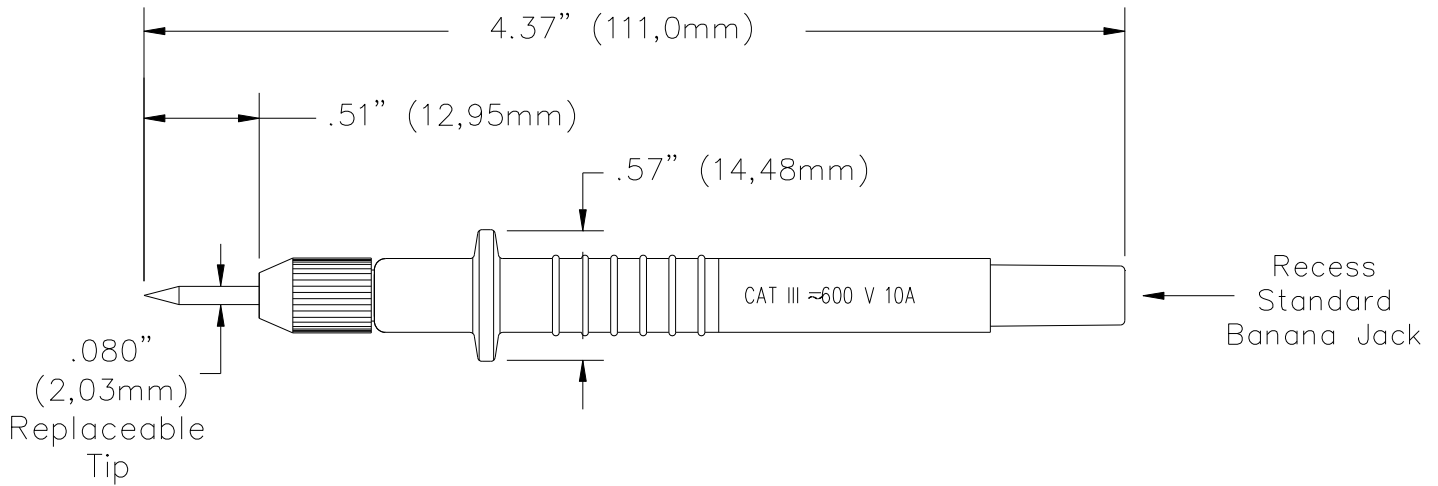

FEATURES:

- ✓ Modular Test Probe
- ✓ Replaceable tip
- ✓ Comes with two Stainless-Steel Sharp Point Tips: Model 4172

MATERIALS:

Replaceable Tip Probe: Stainless Steel

Tip O.D.: 0.080"

Body: Nylon

RATINGS:

Operating Voltage: 600 Vrms per IEC2020-2-031, Category III.

Operating Current: 10 Amperes

ORDERING INFORMATION:

Model 5689A

Replaceable Tips:

Model 5688: Standard

Model 4172: Stainless-Steel Sharp Point

Model 5133: SMD Microtip, Stainless-Steel Sharp Point

Model 4988: Needle Stainless-Steel Sharp Point

Model 6364: Set of tips

Modular Test Leads:

Model 5907A: Right-Angle Banana Plug to Straight Banana Plug

Model 5908A: Straight Banana Plug to Straight Banana Plug

Model 5909A: Right-Angle Banana Plug to Right-Angle Banana Plug



All dimensions are in inches. Tolerances (except noted): .xx = ±.02" (.51 mm), .xxx = ±.005" (.127 mm).

All specifications are to the latest revisions. Specifications are subject to change without notice.

Registered trademarks are the property of their respective companies.

Sales: 800-490-2361 Fax: 888-403-3360 Technical Support: 800-241-2060 (technicalsupport@pomonatest.com)
For "Where to Buy" information, visit the Pomona web site at www.pomonaelectronics.com